

# YASKAWA AC Drive – A1000 HHP

High Performance Vector Control Drive

## Programming Manual

**Type:** CIMR-AU

**Model:** 400 V Class: 414 A to 2000 A Heavy Duty/Normal Duty

600 V Class: 414 A to 2000 A Heavy Duty/Normal Duty

690 V Class: 414 A to 2000 A Heavy Duty/Normal Duty

To properly use the product, read this manual thoroughly and retain for easy reference, inspection, and maintenance. Ensure the end user receives this manual.

Parameter Details **1**

Troubleshooting **2**

Parameter List **A**

MEMOBUS/Modbus  
Communications **B**

---

**This Page Intentionally Blank**

Copyright © 2011 YASKAWA AMERICA, INC. All rights reserved.

No part of this publication may be reproduced, stored in a retrieval system, or transmitted, in any form or by any means, mechanical, electronic, photocopying, recording, or otherwise, without the prior written permission of Yaskawa. No patent liability is assumed with respect to the use of the information contained herein. Moreover, because Yaskawa is constantly striving to improve its high-quality products, the information contained in this manual is subject to change without notice. Every precaution has been taken in the preparation of this manual. Yaskawa assumes no responsibility for errors or omissions. Neither is any liability assumed for damages resulting from the use of the information contained in this publication.

# Table of Contents

<b>1. PARAMETER DETAILS</b>	<b>9</b>
<b>1.1 A: Initialization</b>	<b>10</b>
A1: Initialization	10
A2: User Parameters	17
<b>1.2 b: Application</b>	<b>18</b>
b1: Operation Mode Selection	18
b2: DC Injection Braking and Short Circuit Braking	25
b3: Speed Search	27
b4: Delay Timers	32
b5: PID Control	33
b6: Dwell Function	42
b7: Droop Control (CLV, CLV/PM)	43
b9: Zero Servo	44
<b>1.3 C: Tuning</b>	<b>46</b>
C1: Acceleration and Deceleration Times	46
C2: S-Curve Characteristics	48
C3: Slip Compensation	48
C4: Torque Compensation	51
C5: Automatic Speed Regulator (ASR)	53
C6: Carrier Frequency	57
<b>1.4 d: Reference Settings</b>	<b>59</b>
d1: Frequency Reference	59
d2: Frequency Upper/Lower Limits	61
d3: Jump Frequency	62
d4: Frequency Reference Hold and Up/Down 2 Function	63
d5: Torque Control	67
d6: Field Weakening and Field Forcing	72
d7: Offset Frequency	73
<b>1.5 E: Motor Parameters</b>	<b>74</b>
E1: V/f Pattern for Motor 1	74
E2: Motor 1 Parameters	77
E3: V/f Pattern for Motor 2	80
E4: Motor 2 Parameters	81
<b>1.6 F: Option Settings</b>	<b>84</b>
F1: PG Speed Control Card Settings	84
F2: Analog Input Card Settings	86
F3: Digital Input Card Settings	87
F4: Analog Monitor Card Settings	87

F5: Digital Output Card Settings.....	88
F6: Communication Option Card.....	89
CC-Link Parameters.....	90
PROFIBUS-DP Parameters.....	91
CANopen Parameters.....	91
DeviceNet Parameters.....	92
<b>1.7 H: Terminal Functions.....</b>	<b>94</b>
H1: Multi-Function Digital Inputs.....	94
H2: Multi-Function Digital Outputs.....	104
H3: Multi-Function Analog Inputs.....	114
H4: Multi-Function Analog Outputs.....	120
H5: MEMOBUS/Modbus Serial Communication.....	121
H6: Pulse Train Input/Output.....	123
<b>1.8 L: Protection Functions.....</b>	<b>126</b>
L1: Motor Protection.....	126
L2: Momentary Power Loss Ride-Thru.....	132
L3: Stall Prevention.....	139
L4: Speed Detection.....	143
L5: Fault Restart.....	145
L6: Torque Detection.....	146
L7: Torque Limit.....	149
L8: Drive Protection.....	150
<b>1.9 n: Special Adjustments.....</b>	<b>156</b>
n1: Hunting Prevention.....	156
n2: Speed Feedback Detection Control (AFR) Tuning.....	156
n3: High Slip Braking (HSB) and Overexcitation Braking.....	157
<b>1.10 o: Operator Related Settings.....</b>	<b>159</b>
o1: Digital Operator Display Selection.....	159
o2: Digital Operator Keypad Functions.....	160
o3: Copy Function.....	162
o4: Maintenance Monitor Settings.....	163
q: DriveWorksEZ Parameters.....	164
r: DriveWorksEZ Connection Parameters.....	164
<b>1.11 T: Motor Tuning.....</b>	<b>165</b>
T1: Parameter Settings during Induction Motor Auto-Tuning.....	165
Parameter Settings during Inertia and Speed Control Loop Auto-Tuning: T3.....	167
<b>1.12 U: Monitor Parameters.....</b>	<b>169</b>
U1: Operation Status Monitors.....	169
U2: Fault Trace.....	169
U3: Fault History.....	169
U4: Maintenance Monitors.....	169
U5: PID Monitors.....	169
U6: Operation Status Monitors.....	169
U8: DriveWorksEZ Monitors.....	170
<b>2. TROUBLESHOOTING.....</b>	<b>171</b>
<b>2.1 Section Safety.....</b>	<b>172</b>
<b>2.2 Motor Performance Fine-Tuning.....</b>	<b>174</b>
Fine-Tuning V/f Control and V/f Control with PG.....	174
Fine-Tuning Open Loop Vector Control.....	175

Parameters to Minimize Motor Hunting and Oscillation .....	176
<b>2.3 Drive Alarms, Faults, and Errors .....</b>	<b>177</b>
Types of Alarms, Faults, and Errors .....	177
Alarm and Error Displays .....	177
<b>2.4 Fault Detection .....</b>	<b>182</b>
Fault Displays, Causes, and Possible Solutions .....	182
<b>2.5 Alarm Detection .....</b>	<b>201</b>
Alarm Codes, Causes, and Possible Solutions .....	201
<b>2.6 Operator Programming Errors .....</b>	<b>210</b>
Operator Programming Error Codes, Causes, and Possible Solutions .....	210
<b>2.7 Auto-Tuning Fault Detection .....</b>	<b>214</b>
Auto-Tuning Codes, Causes, and Possible Solutions .....	214
<b>2.8 Copy Function Related Displays .....</b>	<b>219</b>
Tasks, Errors, and Troubleshooting .....	219
<b>2.9 Diagnosing and Resetting Faults .....</b>	<b>221</b>
Fault Occurs Simultaneously with Power Loss .....	221
If the Drive Still has Power After a Fault Occurs .....	221
Viewing Fault Trace Data After Fault .....	221
Fault Reset Methods .....	222
<b>2.10 Troubleshooting without Fault Display .....</b>	<b>223</b>
Common Problems .....	223
Cannot Change Parameter Settings .....	223
Motor Does Not Rotate Properly after Pressing RUN Button or after Entering External Run Command .....	224
Motor is Too Hot .....	225
Drive Does Not Allow Selection of the Desired Auto-Tuning Mode .....	226
oPE02 Error Occurs When Lowering the Motor Rated Current Setting .....	226
Motor Stalls during Acceleration or Acceleration Time is Too Long .....	226
Drive Frequency Reference Differs from the Controller Frequency Reference Command .....	227
Excessive Motor Oscillation and Erratic Rotation .....	227
Deceleration Takes Longer Than Expected with Dynamic Braking Enabled .....	227
Noise From Drive or Motor Cables When the Drive is Powered On .....	228
Ground Fault Circuit Interrupter (GFCI) Trips During Run .....	228
Connected Machinery Vibrates When Motor Rotates .....	228
PID Output Fault .....	229
Insufficient Starting Torque .....	229
Motor Rotates After the Drive Output is Shut Off (Motor Rotates During DC Injection Braking) .....	229
Output Frequency is Not as High as Frequency Reference .....	229
Sound from Motor .....	229
Motor Does Not Restart after Power Loss .....	230
<b>A. PARAMETER LIST .....</b>	<b>231</b>
<b>A.1 Understanding Parameter Descriptions .....</b>	<b>232</b>
A1-02 Control Modes, Symbols, and Terms .....	232
<b>A.2 Parameter Groups .....</b>	<b>233</b>
Parameter Differences for Models CIMR-A□4A0930 and 4A1200 .....	233
<b>A.3 A: Initialization Parameters .....</b>	<b>235</b>
A1: Initialization .....	235
A2: User Parameters .....	236

<b>A.4</b>	<b>b: Application</b> .....	<b>237</b>
	b1: Operation Mode Selection.....	237
	b2: DC Injection Braking and Short Circuit Braking.....	238
	b3: Speed Search.....	239
	b4: Timer Function .....	240
	b5: PID Control.....	240
	b6: Dwell Function.....	242
	b7: Droop Control .....	242
	b9: Zero Servo.....	243
<b>A.5</b>	<b>C: Tuning</b> .....	<b>244</b>
	C1: Acceleration and Deceleration Times .....	244
	C2: S-Curve Characteristics.....	245
	C3: Slip Compensation.....	245
	C4: Torque Compensation .....	246
	C5: Automatic Speed Regulator (ASR).....	247
	C6: Carrier Frequency.....	248
<b>A.6</b>	<b>d: References</b> .....	<b>250</b>
	d1: Frequency Reference.....	250
	d2: Frequency Upper/Lower Limits .....	251
	d3: Jump Frequency.....	251
	d4: Frequency Reference Hold and Up/Down 2 Function.....	252
	d5: Torque Control .....	253
	d6: Field Weakening and Field Forcing.....	253
	d7: Offset Frequency.....	254
<b>A.7</b>	<b>E: Motor Parameters</b> .....	<b>255</b>
	E1: V/f Pattern for Motor 1.....	255
	E2: Motor 1 Parameters .....	256
	E3: V/f Pattern for Motor 2.....	257
	E4: Motor 2 Parameters .....	258
<b>A.8</b>	<b>F: Options</b> .....	<b>259</b>
	F1: PG Speed Control Card (PG-X3/PG-B3) .....	259
	F2: Analog Input Card (AI-A3).....	261
	F3: Digital Input Card (DI-A3).....	261
	F4: Analog Monitor Card (AO-A3).....	262
	F5: Digital Output Card (DO-A3).....	262
	F6, F7: Communication Option Card.....	263
<b>A.9</b>	<b>H Parameters: Multi-Function Terminals</b> .....	<b>267</b>
	H1: Multi-Function Digital Inputs .....	267
	H2: Multi-Function Digital Outputs.....	271
	H3: Multi-Function Analog Inputs .....	274
	H4: Analog Outputs .....	277
	H5: MEMOBUS/Modbus Serial Communication .....	277
	H6: Pulse Train Input/Output.....	278
<b>A.10</b>	<b>L: Protection Function</b> .....	<b>280</b>
	L1: Motor Protection .....	280
	L2: Momentary Power Loss Ride-Thru.....	281
	L3: Stall Prevention .....	282
	L4: Speed Detection.....	283
	L5: Fault Restart.....	284
	L6: Torque Detection.....	284
	L7: Torque Limit .....	285

L8: Drive Protection.....	286
<b>A.11 n: Special Adjustment.....</b>	<b>288</b>
n1: Hunting Prevention.....	288
n2: Speed Feedback Detection Control (AFR) Tuning.....	288
n3: High Slip Braking (HSB) and Overexcitation Braking.....	288
<b>A.12 o: Operator-Related Settings .....</b>	<b>290</b>
o1: Digital Operator Display Selection.....	290
o2: Digital Operator Keypad Functions .....	290
o3: Copy Function .....	291
o4: Maintenance Monitor Settings.....	291
<b>A.13 DriveWorksEZ Parameters .....</b>	<b>293</b>
q: DriveWorksEZ Parameters.....	293
r: DriveWorksEZ Connection Parameters .....	293
<b>A.14 T: Motor Tuning .....</b>	<b>294</b>
T1: Induction Motor Auto-Tuning.....	294
T3: ASR and Inertia Tuning.....	295
<b>A.15 U: Monitors.....</b>	<b>296</b>
U1: Operation Status Monitors .....	296
U2: Fault Trace.....	298
U3: Fault History.....	300
U4: Maintenance Monitors .....	300
U5: PID Monitors.....	303
U6: Operation Status Monitors .....	303
U8: DriveWorksEZ Monitors.....	304
<b>A.16 Control Mode Dependent Parameter Default Values .....</b>	<b>305</b>
A1-02 (Motor 1 Control Mode) Dependent Parameters .....	305
E3-01 (Motor 2 Control Mode) Dependent Parameters .....	307
<b>A.17 V/f Pattern Default Values.....</b>	<b>308</b>
<b>A.18 Defaults by Drive Model and Duty Rating ND/HD.....</b>	<b>309</b>
<b>B. MEMOBUS/MODBUS COMMUNICATIONS.....</b>	<b>313</b>
<b>B.1 MEMOBUS/Modbus Configuration .....</b>	<b>314</b>
<b>B.2 Communication Specifications.....</b>	<b>315</b>
<b>B.3 Connecting to a Network .....</b>	<b>316</b>
Network Cable Connection.....	316
Wiring Diagram for Multiple Connections .....	316
Network Termination .....	317
<b>B.4 MEMOBUS/Modbus Setup Parameters .....</b>	<b>319</b>
MEMOBUS/Modbus Serial Communication.....	319
<b>B.5 Drive Operations by MEMOBUS/Modbus.....</b>	<b>322</b>
Observing the Drive Operation.....	322
Controlling the Drive.....	322
<b>B.6 Communications Timing.....</b>	<b>323</b>
Command Messages from Master to Drive.....	323
Response Messages from Drive to Master .....	323
<b>B.7 Message Format .....</b>	<b>324</b>
Message Content .....	324
Slave Address .....	324

## Table of Contents

---

Function Code .....	324
Data .....	324
Error Check .....	324
<b>B.8 Message Examples .....</b>	<b>326</b>
Reading Drive MEMOBUS/Modbus Register Contents .....	326
Loopback Test.....	326
Writing to Multiple Registers.....	326
<b>B.9 MEMOBUS/Modbus Data Table.....</b>	<b>328</b>
Command Data .....	328
Monitor Data.....	329
Broadcast Messages.....	340
Fault Trace Contents.....	341
Alarm Register Contents .....	343
<b>B.10 Enter Command.....</b>	<b>344</b>
Enter Command Types .....	344
Enter Command Settings when Upgrading the Drive.....	344
<b>B.11 Communication Errors .....</b>	<b>345</b>
MEMOBUS/Modbus Error Codes.....	345
Slave Not Responding.....	345
<b>B.12 Self-Diagnostics .....</b>	<b>346</b>
<b>INDEX .....</b>	<b>347</b>



## Parameter Details

---

1.1	A: INITIALIZATION.....	10
1.2	B: APPLICATION.....	18
1.3	C: TUNING.....	46
1.4	D: REFERENCE SETTINGS.....	59
1.5	E: MOTOR PARAMETERS.....	74
1.6	F: OPTION SETTINGS.....	84
1.7	H: TERMINAL FUNCTIONS.....	94
1.8	L: PROTECTION FUNCTIONS.....	126
1.9	N: SPECIAL ADJUSTMENTS.....	156
1.10	O: OPERATOR RELATED SETTINGS.....	159
1.11	T: MOTOR TUNING.....	165
1.12	U: MONITOR PARAMETERS.....	169

## 1.1 A: Initialization

The initialization group contains parameters associated with initial drive setup, including parameters involving the display language, access levels, initialization, and password.

### ◆ A1: Initialization

#### ■ A1-00: Language Selection

Selects the display language for the digital operator.

**Note:** This parameter is not reset when the drive is initialized using parameter A1-03.

No.	Parameter Name	Setting Range	Default
A1-00	Language Selection	0,1	0

**Setting 0: English**

**Setting 1: Japanese**

#### ■ A1-01: Access Level Selection

Allows or restricts access to drive parameters.

No.	Parameter Name	Setting Range	Default
A1-01	Access Level Selection	0 to 2	2

**Setting 0: Operation only**

Access to only parameters A1-01, A1-04, and all U monitor parameters.

**Setting 1: User Parameters**

Access to only a specific list of parameters set to A2-01 through A2-32. These User Parameters can be accessed using the Setup Mode of the digital operator.

**Setting 2: Advanced Access Level (A) and Setup Access Level (S)**

All parameters can be viewed and edited.

#### Notes on Parameter Access

- If the drive parameters are password protected by A1-04 and A1-05, parameters A1-00 through A1-03, A1-06, and all A2 parameters cannot be modified.
- If a digital input terminal programmed for “Program lockout” (H1-□□ = 1B) is enabled, parameter values cannot be modified, even if A1-01 is set to 1 or 2.
- If parameters are changed via serial communication, it will not be possible to edit or change parameter settings with the digital operator until an Enter command is issued to the drive from the serial communication.

#### ■ A1-02: Control Method Selection

Selects the Control Method (also referred to as the control mode) that the drive uses to operate the motor. Parameter A1-02 determines the control mode for motor 1 when the drive is set up to run two motors.

**Note:** When changing control modes, all parameter settings depending upon the setting of A1-02 will be reset to the default.

No.	Parameter Name	Setting Range	Default
A1-02	Control Method Selection	0, 1, 2, 3	2

#### *Control Modes for Induction Motors (IM)*

##### **Setting 0: V/f Control for Induction Motors**

Use this mode for simple speed control and for multiple motor applications with low demands to dynamic response or speed accuracy. This control mode is also used when the motor parameters are unknown and Auto-Tuning cannot be performed. The speed control range is 1:40.

**Setting 1: V/f Control with PG Speed Feedback**

Use this mode for general-purpose applications that require high speed accuracy but do not require high dynamic response. This control mode is also used when the motor parameters are unknown and Auto-Tuning cannot be performed. The speed control range is 1:40.

**Setting 2: Open Loop Vector Control**

Use this mode for general, variable-speed applications with a speed control range of 1:200 that require precise speed control, quick torque response, and high torque at low speed without using a speed feedback signal from the motor.

**Setting 3: Closed Loop Vector Control**

Use this mode for general, variable-speed applications that require precise speed control down to zero speed, quick torque response or precise torque control, and a speed feedback signal from the motor. The speed control range is up to 1:1500.

**■ A1-03: Initialize Parameters**

Resets parameters to default values. After initialization, the setting for A1-03 automatically returns to 0.

No.	Parameter Name	Setting Range	Default
A1-03	Initialize Parameters	0, 1110, 2220, 3330, 5550	0

**Setting 1110: User Initialize**

Resets parameters to the values selected by the user as User Settings. User Settings are stored when parameter o2-03 is set to "1: Set defaults".

**Note:** User Initialization resets all parameters to a user-defined set of default values previously saved to the drive. Set parameter o2-03 to 2 to clear the user-defined default values.

**Setting 2220: 2-Wire Initialization**

Resets parameters to default settings with digital inputs S1 and S2 configured as Forward run and Reverse run, respectively. [Refer to Setting 40, 41: Forward Run, Reverse Run Command for 2-Wire Sequence on page 101](#) for more information on digital input functions.

**Setting 3330: 3-Wire Initialization**

Resets parameters to default settings with digital inputs S1, S2, and S5 configured as Run, Stop, and Forward/Reverse respectively. [Refer to Setting 0: 3-Wire Sequence on page 95](#) for more information on digital input functions.

**Setting 5550: oPE04 Reset**

An oPE04 error appears on the digital operator when a terminal block with settings saved to its built-in memory is installed in a drive that has edited parameters. Set A1-03 to 5550 to use the parameter settings saved to the terminal block memory.

**Notes on Parameter Initialization**

The parameters shown in [Table 1.1](#) will not be reset when the drive is initialized by setting A1-03 = 2220 or 3330. Although the control mode in A1-02 is not reset when A1-03 is set to 2220 or 3330, it may change when an application preset is selected.

**Table 1.1 Parameters Not Changed by Drive Initialization**

No.	Parameter Name
A1-00	Language Selection
A1-02	Control Method Selection
C6-01	Duty Selection
E1-03	V/f Pattern Selection
F6-08	Communication Parameter Reset
L8-35	Installation Selection
o2-04	Drive/kVA Selection

**■ A1-04, A1-05: Password and Password Setting**

Parameter A1-04 enters the password when the drive is locked; parameter A1-05 is a hidden parameter that sets the password.

No.	Parameter Name	Setting Range	Default
A1-04	Password	0000 to 9999	0000
A1-05	Password Setting		

## 1.1 A: Initialization

### How to Use the Password

The user can set a password in parameter A1-05 to restrict access to the drive. The password must be entered to A1-04 to unlock parameter access (i.e., parameter setting A1-04 must match the value programmed into A1-05). The following parameters cannot be viewed or edited until the value entered to A1-04 correctly matches the value set to A1-05: A1-01, A1-02, A1-03, A1-06, and A2-01 through A2-33.

The instructions below demonstrate how to set password “1234”. An explanation follows on how to enter that password to unlock the parameters.

**Table 1.2 Setting the Password for Parameter Lock**

Step		Display/Result
1.	Turn on the power to the drive. The initial display appears.	
2.	Press  or  until the Parameter Setting Mode screen appears.	
3.	Press  to enter the parameter menu tree.	
4.	Select the flashing digits by pressing  left,  right, or .	
5.	Select A1-04 by pressing .	
6.	Press  while holding down  at the same time. A1-05 will appear. <b>Note:</b> A1-05 is hidden and will not display by pressing only .	
7.	Press .	
8.	Use  left,  right, , , and  to enter the password.	
9.	Press  to save what was entered.	
10.	The display automatically returns to the display shown in step 6.	

Table 1.3 Check if A1-02 is Locked (continuing from step 10 above)











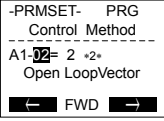

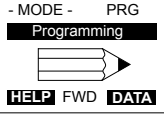

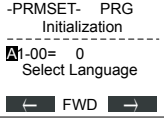



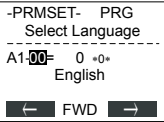

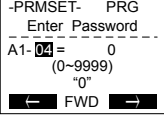
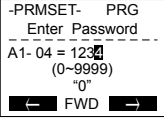
Step		Display/Result
1.	Press  to display A1-02.	
2.	Press  , making sure that the setting values cannot be changed.	
3.	Press  to return to the first display.	

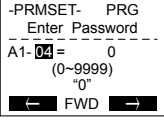
Table 1.4 Enter the Password to Unlock Parameters (continuing from step 3 above)

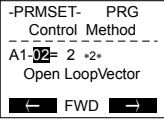
Step		Display/Result
1.	Press  to enter the parameter setup display.	
2.	Press  left,  right,  to select the flashing digits as shown.	
3.	Press  to scroll to A1-04 and  .	
4.	Enter the password “1234”.	
5.	Press  to save the new password.	
6.	Drive returns to the parameter display.	
7.	Press  and scroll to A1-02.	
8.	Press  to display the value set to A1-02. If the first “0” blinks, parameter settings are unlocked.	
9.	Use  and  to change the value if desired (though changing the control mode at this point is not typically done).	

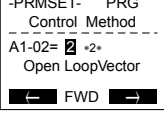
## 1.1 A: Initialization

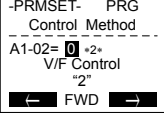
Step			Display/Result
10.	Press  to save the setting, or press  to return to the previous display without saving changes.	→	
11.	The display automatically returns to the parameter display.	→	

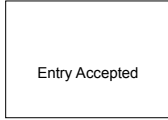
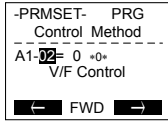
- Note:**
1. Parameter settings can be edited after entering the correct password.
  2. Performing a 2-Wire or 3-Wire initialization resets the password to “0000”.

### ■ A1-06: Application Preset

Several Application Presets are available to facilitate drive setup for commonly used applications. Selecting one of these Application Presets automatically assigns functions to the input and output terminals and sets a predefined group of parameters to values appropriate for the selected application.

In addition, the parameters most likely to be changed are assigned to the group of User Parameters, A2-01 through A2-16. User Parameters are part of the Setup Group, which provides quicker access by eliminating the need to scroll through multiple menus.

#### Setting 1: Water Supply Pump Application

Table 1.5 Water Supply Pump: Parameter Settings

No.	Name	Default Setting
A1-02	Control Method Selection	0: V/f Control
b1-04	Reverse Operation Selection	1: Reverse Prohibited
C1-01	Acceleration Time 1	1.0 s
C1-02	Deceleration Time 1	1.0 s
C6-01	Duty Rating	1: Normal Duty
E1-03	V/f Pattern Selection	0FH
E1-07	Mid Output Frequency	30.0 Hz
E1-08	Mid Output Frequency Voltage	50.0 V
L2-01	Momentary Power Loss Operation Selection	1: Enabled
L3-04	Stall Prevention Selection during Deceleration	1: Enabled

Table 1.6 Water Supply Pump: User Parameters (A2-01 to A2-16)

No.	Parameter Name	No.	Parameter Name
b1-01	Frequency Reference Selection	E1-08	Mid Output Frequency Voltage
b1-02	Run Command Selection	E2-01	Motor Rated Current
b1-04	Reverse Operation Selection	H1-05	Multi-Function Digital Input Terminal S5 Function Selection
C1-01	Acceleration Time 1	H1-06	Multi-Function Digital Input Terminal S6 Function Selection
C1-02	Deceleration Time 1	H1-07	Multi-Function Digital Input Terminal S7 Function Selection
E1-03	V/f Pattern Selection	L5-01	Number of Auto Restart Attempts
E1-07	Mid Output Frequency	–	–

#### Setting 2: Conveyor Application

Table 1.7 Conveyor: Parameter Settings

No.	Parameter Name	Default Setting
A1-02	Control Method Selection	0: V/f Control
C1-01	Acceleration Time 1	3.0 s
C1-02	Deceleration Time 1	3.0 s

No.	Parameter Name	Default Setting
C6-01	Duty Rating	0: Heavy Duty
L3-04	Stall Prevention Selection during Deceleration	1: Enabled

Table 1.8 Conveyor: User Parameters (A2-01 to A2-16)

No.	Parameter Name	No.	Parameter Name
A1-02	Control Method Selection	C1-02	Deceleration Time 1
b1-01	Frequency Reference Selection	E2-01	Motor Rated Current
b1-02	Run Command Selection	L3-04	Stall Prevention Selection during Deceleration
C1-01	Acceleration Time 1	–	–

## Setting 3: Exhaust Fan Application

Table 1.9 Exhaust Fan: Parameter Settings

No.	Parameter Name	Default Setting
A1-02	Control Method Selection	0: V/f Control
b1-04	Reverse Operation Selection	1: Reverse Prohibited
C6-01	Duty Selection	1: Normal Duty
E1-03	V/f Pattern Selection	0FH
E1-07	Mid Output Frequency	30.0 Hz
E1-08	Mid Output Frequency Voltage	50.0 V
L2-01	Momentary Power Loss Operation Selection	1: Enabled
L3-04	Stall Prevention Selection during Deceleration	1: Enabled

Table 1.10 Exhaust Fan: User Parameters (A2-01 to A2-16)

No.	Parameter Name	No.	Parameter Name
b1-01	Frequency Reference Selection	E1-07	Mid Output Frequency
b1-02	Run Command Selection	E1-08	Mid Output Frequency Voltage
b1-04	Reverse Operation Selection	E2-01	Motor Rated Current
b3-01	Speed Search Selection at Start	H1-05	Multi-Function Digital Input Terminal S5 Function Selection
C1-01	Acceleration Time 1	H1-06	Multi-Function Digital Input Terminal S6 Function Selection
C1-02	Deceleration Time 1	H1-07	Multi-Function Digital Input Terminal S7 Function Selection
E1-03	V/f Pattern Selection	L5-01	Number of Auto Restart Attempts

## Setting 4: HVAC Fan Application

Table 1.11 HVAC Fan: Parameter Settings

No.	Parameter Name	Default Setting
A1-02	Control Method Selection	0: V/f Control
b1-04	Reverse Operation Selection	1: Reverse Prohibited
b1-17	Run Command at Power Up	1: Run command issued, motor operation start
C6-01	Duty Rating	1: Normal Duty
C6-02	Carrier Frequency Selection	3: 8.0 kHz
H2-03	Terminals P2 Function Selection	39: Watt Hour Pulse Output
L2-01	Momentary Power Loss Operation Selection	2: CPU Power Active - Drive will restart if power returns prior to control power supply shut down.
L8-03	Overheat Pre-Alarm Operation Selection	4: Operation at lower speed
L8-38	Carrier Frequency Reduction	2: Enabled across entire frequency range.

## 1.1 A: Initialization

Table 1.12 HVAC Fan: User Parameters (A2-01 to A2-16)

No.	Parameter Name	No.	Parameter Name
b1-01	Frequency Reference Selection	d2-02	Frequency Reference Lower Limit
b1-02	Run Command Selection	E1-03	V/f Pattern Selection
b1-03	Stopping Method Selection	E1-04	Max Output Frequency
b1-04	Reverse Operation Selection	E2-01	Motor Rated Current
C1-01	Acceleration Time 1	H3-11	Terminal A2 Gain Setting
C1-02	Deceleration Time 1	H3-12	Terminal A2 Input Bias
C6-02	Carrier Frequency Selection	L2-01	Momentary Power Loss Operation Selection
d2-01	Frequency Reference Upper Limit	o4-12	kWh Monitor Initial Value Selection

### Setting 5: Compressor Application

Table 1.13 Compressor: Parameter Settings

No.	Parameter Name	Default Setting
A1-02	Control Method Selection	0: V/f Control
b1-04	Reverse Operation Selection	1: Reverse Prohibited
C1-01	Acceleration Time 1	5.0 s
C1-02	Deceleration Time 1	5.0 s
C6-01	Duty Rating	0: Heavy Duty
E1-03	V/f Pattern Selection	0F Hex
L2-01	Momentary Power Loss Operation Selection	1: Enabled
L3-04	Stall Prevention Selection during Deceleration	1: Enabled

Table 1.14 Compressor: User Parameters (A2-01 to A2-16):

No.	Parameter Name	No.	Parameter Name
b1-01	Frequency Reference Selection	E1-03	V/f Pattern Selection
b1-02	Run Command Selection	E1-07	Mid Output Frequency
b1-04	Reverse Operation Selection	E1-08	Mid Output Frequency Voltage
C1-01	Acceleration Time 1	E2-01	Motor Rated Current
C1-02	Deceleration Time 1	–	–

### ■ A1-07: DriveWorksEZ Function Selection

Enables and disables the DriveWorksEZ program inside the drive.

DriveWorksEZ is a software package for customizing drive functionality or adding PLC functionality by the interconnection and configuration of basic software function blocks. The drive performs user-created programs in 1 ms cycles.

- Note:**
1. If DriveWorksEZ has assigned functions to any of the multi-function output terminals, those functions will remain set to those terminals even after disabling DriveWorksEZ.
  2. For more information on DriveWorksEZ, contact a Yaskawa representative.

No.	Parameter Name	Setting Range	Default
A1-07	DriveWorksEZ Function Selection	0 to 2	0

**Setting 0: DWEZ disabled**

**Setting 1: DWEZ enabled**

**Setting 2: Digital input**

If a digital input is programmed for DWEZ enable/disable (H1-□□ = 9F), DWEZ will be enabled when the input is opened.



## ◆ A2: User Parameters

### ■ A2-01 to A2-32: User Parameters 1 to 32

The user can select up to 32 parameters and assign them to parameters A2-01 through A2-32 to provide quicker access by eliminating the need to scroll through multiple menus. The User Parameter list can also save the most recently edited parameters.

No.	Parameter Name	Setting Range	Default
A2-01 to A2-32	User Parameters 1 to 32	b1-01 to o4-13	Determined by A1-06 <I>

<I> A1-06 determines how parameters edited by the user are saved to the list of User Parameters, A2-01 through A2-32.

#### Saving User Parameters

To save specific parameters to A2-01 through A2-32, set parameter A1-01 to 2 to allow access to all parameters, then enter the parameter number to one of the A2-□□ parameters to assign it to the list of User Parameters. Finally, set A1-01 to 1 to restrict access so users can only set and refer to the parameters saved as User Parameters.

### ■ A2-33: User Parameter Automatic Selection

Determines whether recently edited parameters are saved to the second half of the User Parameters (A2-17 to A2-32) for quicker access.

No.	Parameter Name	Setting Range	Default
A2-33	User Parameter Automatic Selection	0, 1	Determined by A1-06

#### Setting 0: Do not save list of recently edited parameters

Set A2-33 to 0 to manually select the parameters listed in the User Parameter group.

#### Setting 1: Save list of recently edited parameters

Set A2-33 to 1 to automatically save recently edited parameters to A2-17 through A2-32. A total of 16 parameters are saved with the most recently edited parameter set to A2-17, the second most recently to A2-18, and so on. Access the User Parameters using the Setup Mode of the digital operator.

## 1.2 b: Application

### ◆ b1: Operation Mode Selection

#### ■ b1-01: Frequency Reference Selection 1

Selects the frequency reference source 1 for the REMOTE mode.

- Note:**
1. If a Run command is input to the drive but the frequency reference entered is 0 or below the minimum frequency, the RUN indicator LED on the digital operator will light and the STOP indicator will flash.
  2. Press the LO/RE key to set the drive to LOCAL and use the operator keypad to enter the frequency reference.

No.	Parameter Name	Setting Range	Default
b1-01	Frequency Reference Selection 1	0 to 4	1

#### Setting 0: Operator keypad

Using this setting, the frequency reference can be input by:

- switching between the multi-speed references in the d1-□□ parameters.
- entering the frequency reference on the operator keypad.

#### Setting 1: Terminals (analog input terminals)

Using this setting, an analog frequency reference can be entered as a voltage or current signal from terminals A1, A2, or A3.

##### Voltage Input

Voltage input can be used at any of the three analog input terminals. Make the settings as described in [Table 1.15](#) for the input used.

**Table 1.15 Analog Input Settings for Frequency Reference Using Voltage Signals**

Terminal	Signal Level	Parameter Settings				Notes
		Signal Level Selection	Function Selection	Gain	Bias	
A1	0 to 10 Vdc	H3-01 = 0	H3-02 = 0 (Frequency Reference Bias)	H3-03	H3-04	-
	-10 to +10 Vdc	H3-01 = 1				
A2	0 to 10 Vdc	H3-09 = 0	H3-10 = 0 (Frequency Reference Bias)	H3-11	H3-12	Set DIP switch S1 on the terminal board to “V” for voltage input.
	-10 to +10 Vdc	H3-09 = 1				
A3	0 to 10 Vdc	H3-05 = 0	H3-06 = 0 (Frequency Reference Bias)	H3-07	H3-08	Set DIP switch S4 on the terminal board to “AI”.
	-10 to +10 Vdc	H3-05 = 1				

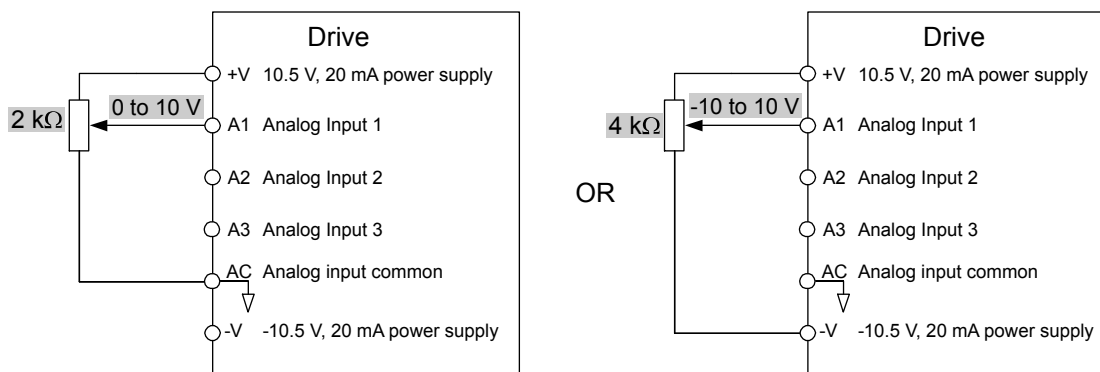

**Figure 1.1 Setting the Frequency Reference as a Voltage Signal at Terminal A1**

Use the wiring example shown in [Figure 1.1](#) for any other analog input terminals. When using input A2 make sure DIP switch S1 is set for voltage input.

##### Current Input

Input terminal A2 can accept a current input signal. Refer to [Table 1.16](#) to set terminal A2 for current input.

Table 1.16 Analog Input Settings for Frequency Reference Using a Current Signal

Terminal	Signal Level	Parameter Settings				Notes
		Signal Level Selection	Function Selection	Gain	Bias	
A2	4 to 20 mA	H3-09 = 2	H3-10 = 0 (Frequency Bias)	H3-11	H3-12	Make sure to set DIP switch S1 on the terminal board to "I" for current input.
	0 to 20 mA	H3-09 = 3				

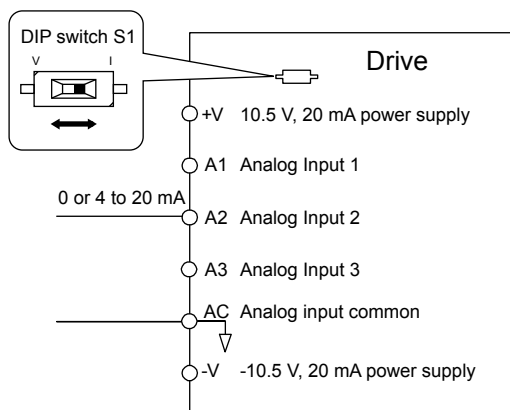

Figure 1.2 Setting the Frequency Reference as a Current Signal to Terminal A2

**Switching between Main/Auxiliary Frequency References**

The frequency reference input can be switched between the analog terminals A1, A2, and A3 using multi-speed inputs. Refer to *Multi-Step Speed Selection on page 59* for details on using this function.

**Setting 2: MEMOBUS/Modbus Communications**

This setting requires entering the frequency reference via the RS-485/422 serial communications port (control terminals R+, R-, S+, S-).

**Setting 3: Option card**

This setting requires entering the frequency reference via an option board plugged into connector CN5-A on the drive control board. Consult the option board manual for instructions on integrating the drive with the communication system.

**Note:** If the frequency reference source is set for Option PCB (b1-01 = 3), but an option board is not installed, an oPE05 Operator Programming Error will be displayed on the digital operator and the drive will not run.

**Setting 4: Pulse Train Input**

This setting requires a pulse train signal to terminal RP to provide the frequency reference. Follow the directions below to verify that the pulse signal is working properly.

**Verifying the Pulse Train is Working Properly**

- Set b1-04 to 4 and set H6-01 to 0.
- Set the H6-02 to the pulse train frequency value that equals 100% of the frequency reference.
- Enter a pulse train signal to terminal RP and check for the correct frequency reference on the display.

**■ b1-02: Run Command Selection 1**

Determines the Run command source 1 in the REMOTE mode.

No.	Parameter Name	Setting Range	Default
b1-02	Run Command Selection 1	0 to 3	1

**Setting 0: Operator**

This setting requires entering the Run command via the digital operator RUN key and also illuminates the LO/RE indicator on the digital operator.

**Setting 1: Control Circuit Terminal**

This setting requires entering the Run command via the digital input terminals using one of following sequences:

- 2-Wire sequence 1:

## 1.2 b: Application

Two inputs (FWD/Stop-REV/Stop). Set A1-03 to 2220 to initialize the drive and preset terminals S1 and S2 to these functions. This is the default setting of the drive. *Refer to Setting 40, 41: Forward Run, Reverse Run Command for 2-Wire Sequence on page 101.*

- 2-Wire sequence 2:

Two inputs (Start/Stop-FWD/REV). *Refer to Setting 42, 43: Run and Direction Command for 2-Wire Sequence 2 on page 102.*

- 3-Wire sequence:

Three inputs (Start-Stop-FWD/REV). Set A1-03 to 3330 to initialize the drive and preset terminals S1, S2, and S5 to these functions. *Refer to Setting 0: 3-Wire Sequence on page 95.*

### Setting 2: MEMOBUS/Modbus Communications

This setting requires entering the frequency reference via the RS-485/422 serial communications port (control terminals R+, R-, S+, S-).

### Setting 3: Option Card

This setting requires entering the Run command via the communication option board by plugging a communication option board into the CN5-A port on the control PCB. Refer to the option board manual for instructions on integrating the drive into the communication system.

**Note:** If b1-02 is set to 3, but an option board is not installed in CN5-A, an oPE05 operator programming error will be displayed on the digital operator and the drive will not run.

## ■ b1-03: Stopping Method Selection

Selects how the drive stops the motor when the Run command is removed or when a Stop command is entered.

No.	Parameter Name	Setting Range	Default
b1-03	Stopping Method Selection	0 to 3	0

### Setting 0: Ramp to Stop

When the Run command is removed, the drive will decelerate the motor to stop. The deceleration rate is determined by the active deceleration time. The default deceleration time is set to parameter C1-02.

When the output frequency falls below the level set in parameter b2-01, the drive will start DC injection, Zero Speed Control, or Short Circuit Braking, depending on the selected control mode. *Refer to b2-01: DC Injection Braking Start Frequency on page 25* for details.

### Setting 1: Coast to Stop

When the Run command is removed, the drive will shut off its output and the motor will coast (uncontrolled deceleration) to stop. The stopping time is determined by the inertia and the friction in the driven system.

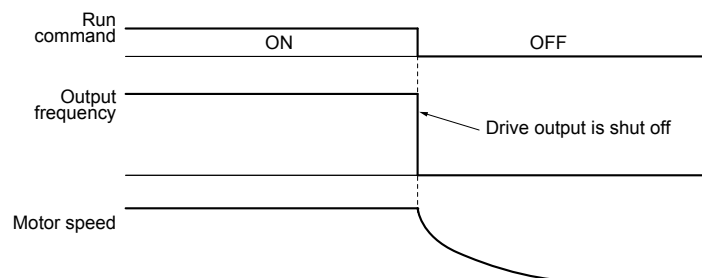

Figure 1.3 Coast to Stop

**Note:** After a stop is initiated, any subsequent Run command entered will be ignored until the minimum baseblock time (L2-03) has expired. Do not enter Run command until it has come to a complete stop. Use DC Injection at Start (*Refer to b2-03: DC Injection Braking Time at Start on page 26*) or Speed Search (*Refer to b3: Speed Search on page 27*) to restart the motor before it has completely stopped.

### Setting 2: DC Injection Braking to Stop

When the Run command is removed, the drive will enter baseblock (turn off its output) for the minimum baseblock time (L2-03). When the minimum baseblock time has expired, the drive will inject the amount DC current set in parameter b2-02 into the motor windings to brake the motor. The stopping time in DC Injection Braking to Stop is significantly faster compared to Coast to Stop.

**Note:** This function is not available in the control modes for PM motors (A1-02 = 5, 6, 7).

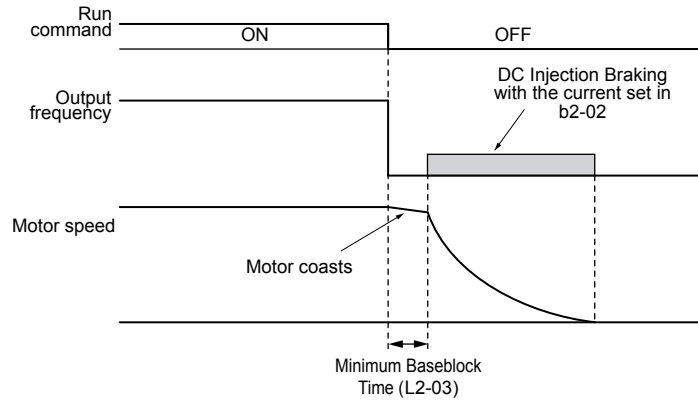

Figure 1.4 DC Injection Braking to Stop

DC Injection Braking time is determined by the value set to b2-04 and the output frequency at the time the Run command is removed. It can be calculated by:

$$\text{DC Injection brake time} = \frac{(b2-04) \cdot 10 \cdot \text{Output frequency}}{\text{Max. output frequency (E1-04)}}$$

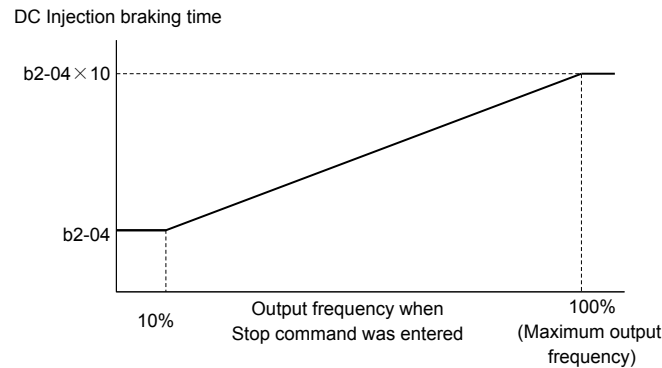

Figure 1.5 DC Injection Braking Time Depending on Output Frequency

**Note:** If an overcurrent (oC) fault occurs during DC Injection Braking to Stop, lengthen the minimum baseblock time (L2-03) until the fault no longer occurs.

**Setting 3: Coast to Stop with Timer**

When the Run command is removed, the drive will turn off its output and the motor will coast to stop. The drive will not start if a Run command is input before the time t (C1-02) has expired. Cycle the Run command that was activated during time t after t has expired to start the drive.

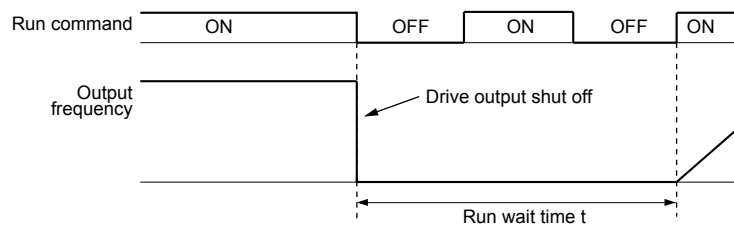

Figure 1.6 Coast to Stop with Timer

The wait time t is determined by the output frequency when the Run command is removed and by the active deceleration time.

## 1.2 b: Application

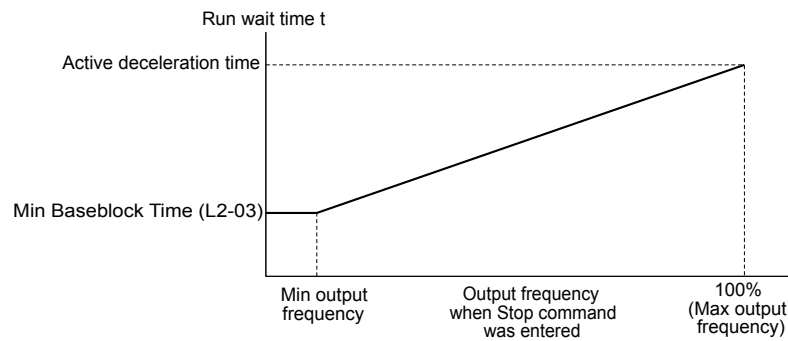

Figure 1.7 Run Wait Time Depending on Output Frequency

### ■ b1-04: Reverse Operation Selection

Enables and disables Reverse operation. For some applications, reverse motor rotation is not appropriate and may cause problems (e.g., air handling units, pumps, etc.).

No.	Parameter Name	Setting Range	Default
b1-04	Reverse Operation Selection	0, 1	0

#### Setting 0: Reverse operation enabled

Possible to operate the motor in both forward and reverse directions.

#### Setting 1: Reverse operation disabled

Drive disregards a Reverse run command or a negative frequency reference.

### ■ b1-05: Action Selection below Minimum Output Frequency (CLV and CLV/PM)

**Note:** PM motor control modes are not available in A1000 HHP drive models.

Sets the operation when the frequency reference is lower than the minimum output frequency set in parameter E1-09.

No.	Parameter Name	Setting Range	Default
b1-05	Action Selection below Minimum Output Frequency	0 to 3	0

#### Setting 0: Follow the Frequency Reference

The drive adjusts the motor speed following the speed reference, even if the frequency reference is below the setting of parameter E1-09. When the Run command is removed and the motor speed is smaller than the setting of b2-01, Zero Speed Control (not position lock) is performed for the time set in parameter b2-04 before the drive output shuts off.

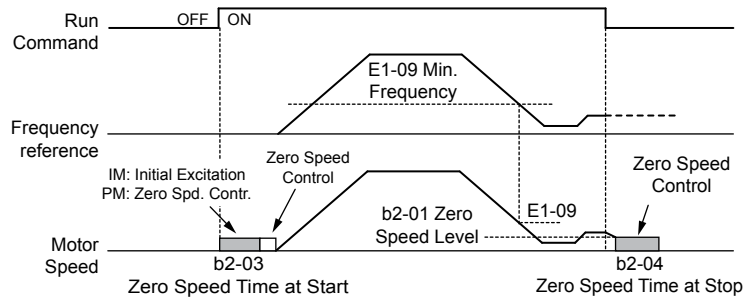

Figure 1.8 Run at the Frequency Reference

#### Setting 1: Coast to Stop

The motor starts when the frequency reference exceeds the parameter E1-09 setting. When the motor is running and the frequency reference falls below E1-09, the drive output shuts off and the motor coasts. When the motor speed falls below the zero speed level set in b2-01, Zero Speed Control is activated for the time set in b2-04.

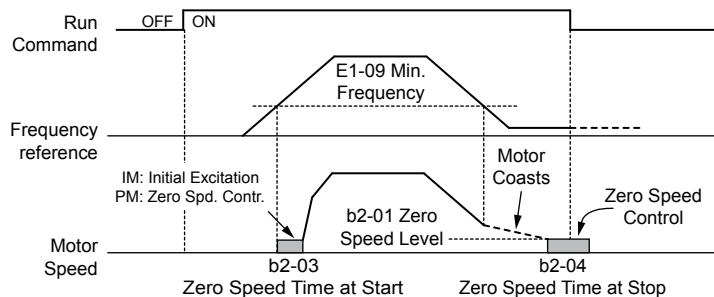

Figure 1.9 Coast to Stop

**Setting 2: Run at the minimum frequency**

When a Run command is active and the frequency reference is smaller than the parameter E1-09 setting, the drive runs the motor at the speed set in E1-09. When the Run command is removed, the drive decelerates the motor. As soon as the motor speed reaches the zero speed level set in b2-01, Zero Speed Control is activated for the time set in b2-04.

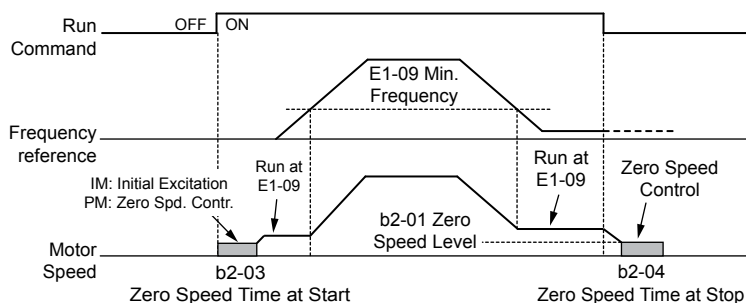

Figure 1.10 Run at the Minimum Frequency

**Setting 3: Zero Speed Control**

The drive applies Zero Speed Control whenever the frequency reference setting is below the value of parameter E1-09. When the Run command is removed, Zero Speed Control is activated for the time set in b2-04, even if it was already active before.

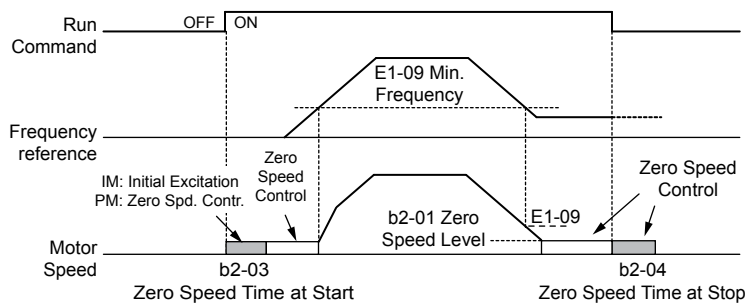

Figure 1.11 Zero Speed Control

■ **b1-06: Digital Input Reading**

Defines how the digital inputs are read. The inputs are acted upon every 1 ms or 2 ms depending upon the setting.

No.	Name	Setting Range	Default
b1-06	Digital Input Reading	0, 1	1

**Setting 0: Read once (1 ms scan)**

The state of a digital input is read once. If the state has changed, the input command is immediately processed. With this setting the drive responds more quickly to digital inputs, but a noisy signal could cause erroneous operation.

**Setting 1: Read twice (2 ms scan)**

The state of a digital input is read twice. The input command is processed only if the state does not change during the double reading. This reading process is slower than the “Read once” process, but it is more resistant to noisy signals.

## 1.2 b: Application

### ■ b1-07: LOCAL/REMOTE Run Selection

The drive has three separate control sources that can be switched using digital inputs (H1-□□ = 1 (LOCAL/REMOTE Selection) or 2 (External reference 1/2)) or the LO/RE key on the digital operator. [Refer to Setting 1: LOCAL/REMOTE Selection on page 95](#), [Refer to Setting 2: External Reference 1/2 Selection on page 96](#) and [Refer to o2-01: LO/RE \(LOCAL/REMOTE\) Key Function Selection on page 160](#) for details.

- LOCAL: Digital operator. The digital operator sets the frequency reference and Run command.
- REMOTE: External reference 1. The frequency reference and Run command source are set by b1-01 and b1-02.
- REMOTE: External reference 2. The frequency reference and Run command source are set by b1-15 and b1-16.

When switching from LOCAL to REMOTE, or between External reference 1 and External reference 2, the Run command may already be present at the location at which the source is being switched. In this case, use parameter b1-07 to determine how the Run command is treated.

No.	Parameter Name	Setting Range	Default
b1-07	LOCAL/REMOTE Run Selection	0, 1	0

#### Setting 0: Run command must be cycled

When the Run command source differs between the old source and the new source (e.g., the old source was the terminals and the new source is serial communication), and the Run command is active at the new source as the switchover occurs, the drive will not start or the drive will stop operation if it was previously running. The Run command must be cycled at the new source to restart the drive.

#### Setting 1: Accept Run command at the new source

When the Run command is active at the new source, the drive starts or continues operation if it was previously running.

**WARNING!** *Sudden Movement Hazard. The drive may start unexpectedly if switching control sources when b1-07 = 1. Clear all personnel from rotating machinery and electrical connections prior to switching control sources. Failure to comply may cause death or serious injury.*

### ■ b1-08: Run command selection while in Programming Mode

As a safety precaution, the drive will not normally respond to a Run command input when the digital operator is being used to adjust parameters in Programming Mode (Verify Menu, Setup Mode, Parameter Settings Mode, and Auto-Tuning Mode). If required by the application, set b1-08 to allow the drive to run while in Programming Mode.

No.	Parameter Name	Setting Range	Default
b1-08	Run Command Selection while in Programming Mode	0 to 2	0

#### Setting 0: Disabled

A Run command is not accepted while the digital operator is in Programming Mode.

#### Setting 1: Enabled

A Run command is accepted in any digital operator mode.

#### Setting 2: Prohibit programming during run

It is not possible to enter the Programming Mode as long as the drive output is active. The Programming Mode cannot be displayed during Run.

### ■ b1-14: Phase Order Selection

Sets the phase order for drive output terminals U/T1, V/T2, and W/T3.

Switching motor phases will reverse the direction of the motor.

No.	Parameter Name	Setting Range	Default
b1-14	Phase Order Selection	0, 1	0

#### Setting 0: Standard Phase Order

#### Setting 1: Switched Phase Order

### ■ b1-15: Frequency Reference Selection 2

[Refer to b1-01: Frequency Reference Selection 1 on page 18.](#)

No.	Parameter Name	Setting Range	Default
b1-15	Frequency Reference Selection 2	0 to 4	0



## ■ b1-16: Run Command Selection 2

Refer to b1-02: Run Command Selection 1 on page 19.

No.	Parameter Name	Setting Range	Default
b1-16	Run Command Selection 2	0 to 3	0

## ■ b1-17: Run Command at Power Up

Determines whether an external Run command that is active during power up will start the drive.

No.	Parameter Name	Setting Range	Default
b1-17	Run Command at Power Up	0, 1	0

### Setting 0: Run Command at Power Up Is Not Issued

Cycle the Run command to start the drive.

**Note:** For safety reasons, the drive is initially programmed not to accept a Run command at power up (b1-17 = 0). If a Run command is issued at power up, the RUN indicator LED will flash quickly.

### Setting 1: Run Command at Power Up Is Issued

If an external Run command is active when the drive is powered up, the drive will begin operating the motor once the internal start up process is complete.

**WARNING!** Sudden Movement Hazard. If b1-17 is set to 1 and an external Run command is active during power up, the motor will begin rotating as soon as the power is switched on. Proper precautions must be taken to ensure that the area around the motor is safe prior to powering up the drive. Failure to comply may cause serious injury.

## ◆ b2: DC Injection Braking and Short Circuit Braking

These parameters determine operation of the DC Injection Braking, Zero Speed Control, and Short Circuit Braking features.

### ■ b2-01: DC Injection Braking Start Frequency

Active when “Ramp to Stop” is selected as the stopping method (b1-03 = 0).

No.	Name	Setting Range	Default
b2-01	DC Injection Braking Start Frequency	0.0 to 10.0 Hz	Determined by A1-02

The function triggered by parameter b2-01 depends on the control mode that has been selected.

#### V/f, V/f w/PG, and OLV (A1-02 = 0, 1, 2)

For these control modes, parameter b2-01 sets the starting frequency for DC Injection Braking at Stop. When the output frequency falls below the setting of b2-01, DC Injection Braking is enabled for the time set in parameter b2-04.

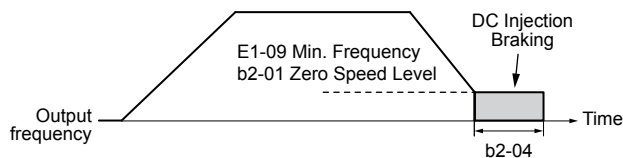

Figure 1.12 DC Injection Braking at Stop for V/f, V/f w/PG and OLV

**Note:** If b2-01 is set to a smaller value than parameter E1-09 (minimum frequency), then DC Injection Braking will begin as soon as the frequency falls to the value set to E1-09.

#### OLV/PM and AOLV/PM (A1-02 = 5, 6)

**Note:** PM motor control modes are not available in A1000 HHP drive models.

For these control modes, parameter b2-01 sets the starting frequency for Short-Circuit Braking at stop. When the output frequency falls below the setting of b2-01, Short-Circuit Braking is enabled for the time set in parameter b2-13. If DC Injection Braking time is enabled at stop, then DC Injection Braking is performed for the time set in b2-04 after Short-Circuit Braking is complete.

## 1.2 b: Application

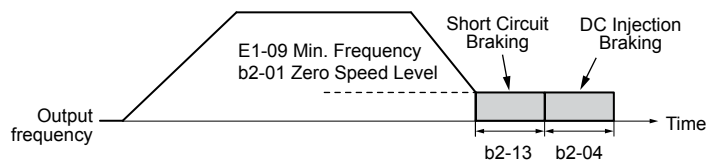

**Figure 1.13 Short-Circuit Braking at Stop in OLV/PM and AOLV/PM**

**Note:** If b2-01 is set to a smaller value than parameter E1-09 (minimum frequency), then DC Injection Braking will begin as soon as the frequency falls to the value set to E1-09.

### CLV and CLV/PM (A1-02 = 3, 7)

**Note:** PM motor control modes are not available in A1000 HHP drive models.

For these control modes, parameter b2-01 sets the starting frequency for Zero Speed Control (not position lock) at stop. When the output frequency falls below the setting of b2-01, Zero Speed Control is enabled for the time set in parameter b2-04 provided b1-05 is set to 0.

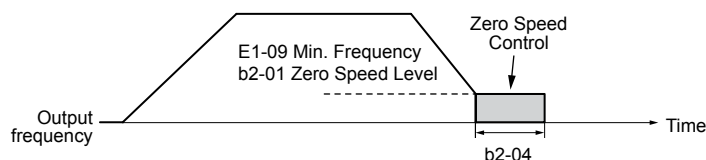

**Figure 1.14 Zero Speed Control at Stop in CLV and CLV/PM**

**Note:** If b2-01 is set lower than the minimum frequency (E1-09), then Zero Speed Control begins at the frequency set to E1-09.

### ■ b2-02: DC Injection Braking Current

Sets the DC Injection Braking current as a percentage of the drive rated current. The carrier frequency is automatically reduced to 1 kHz when this parameter is set to more than 50%.

No.	Name	Setting Range	Default
b2-02	DC Injection Braking Current	0 to 100%	50%

The level of DC Injection Braking current affects the strength of the magnetic field attempting to lock the motor shaft. Increasing the current level will increase the amount of heat generated by the motor windings. Do not set this parameter higher than the level necessary to hold the motor shaft.

### ■ b2-03: DC Injection Braking Time at Start

Sets the time of DC Injection Braking (Zero Speed Control in CLV and CLV/PM) at start. Used to stop a coasting motor before restarting it or to apply braking torque at start. Disabled when set to 0.00 s.

No.	Name	Setting Range	Default
b2-03	DC Injection Braking Time at Start	0.00 to 10.00 s	0.00 s

**Note:** Before starting an uncontrolled rotating motor (e.g., a fan motor driven by windmill effect), use DC Injection or Speed Search to stop the motor or detect motor speed before starting it. Otherwise, motor stalling and other faults can occur.

### ■ b2-04: DC Injection Braking Time at Stop

Sets the time of DC Injection Braking (Zero Speed Control in CLV and CLV/PM) at stop. Used to completely stop a motor with high inertia load after ramp down. Increase the value if the motor still coasts by inertia after it should have stopped. Disabled when set to 0.00 s.

No.	Name	Setting Range	Default
b2-04	DC Injection Braking Time at Stop	0.00 to 10.00 s	Determined by A1-02

### ■ b2-08: Magnetic Flux Compensation Value

Sets the magnetic flux compensation at start as a percentage of the no-load current value (E2-03). This function allows for the development of more flux to facilitate starting machines that require high starting torque or motors with a large rotor time constant.

No.	Name	Setting Range	Default
b2-08	Magnetic Flux Compensation Value	0 to 1000%	0%

When a Run command is issued, the DC current level injected into the motor changes linearly from the level set to b2-08 to the level set to E2-03 within the time set to b2-03.

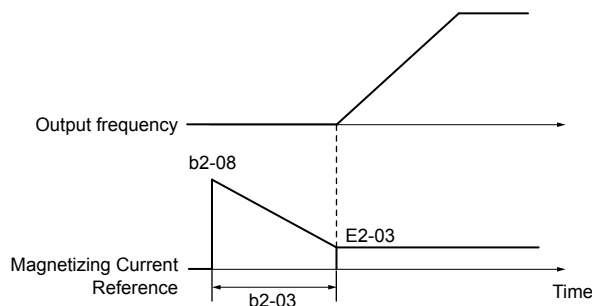

Figure 1.15 Magnetic Flux Compensation

The level of the DC current injected to the motor is limited to 80% of the drive rated current or to the motor rated current, whichever value is smaller.

- Note:**
1. If b2-08 is set below 100%, it can take a relatively long time for flux to develop.
  2. If b2-08 is set to 0%, the DC current level will be the DC Injection current set to b2-02.
  3. As DC Injection can generate a fair amount of noise, b2-08 may need to be adjusted to keep noise levels acceptable.

### ◆ b3: Speed Search

The Speed Search function allows the drive to detect the speed of a rotating motor shaft that is driven by external forces and start the motor operation directly from the detected speed without first stopping the machine.

Example: When a momentary loss of power occurs, the drive output shuts off and the motor coasts. When power returns, the drive can find the speed of the coasting motor and restart it directly.

For PM motors, only parameter b3-01 is needed to enable Speed Search.

For induction motors, the drive offers two types of Speed Search that can be selected by parameter b3-24 (Speed Estimation and Current Detection). Both methods are explained below and followed by a description of all relevant parameters.

#### ■ Current Detection Speed Search (b3-24 = 0)

Current Detection Speed Search detects the motor speed by looking at motor current in IM motors. When Speed Search is started it reduces the output frequency starting from either the maximum output frequency or the frequency reference while increasing the output voltage using the time set in parameter L2-04. As long as the current is higher than the level set to b3-02, the output frequency is lowered using the time constant set to b3-03. If the current falls below b3-02, the drive assumes that the output frequency and motor speed are the same and accelerates or decelerates to the frequency reference.

Be aware that sudden acceleration may occur when using this method of Speed Search with relatively light loads.

*Figure 1.16* illustrates Current Detection Speed Search operation after a momentary power loss (L2-01 must be set to 1 or 2):

## 1.2 b: Application

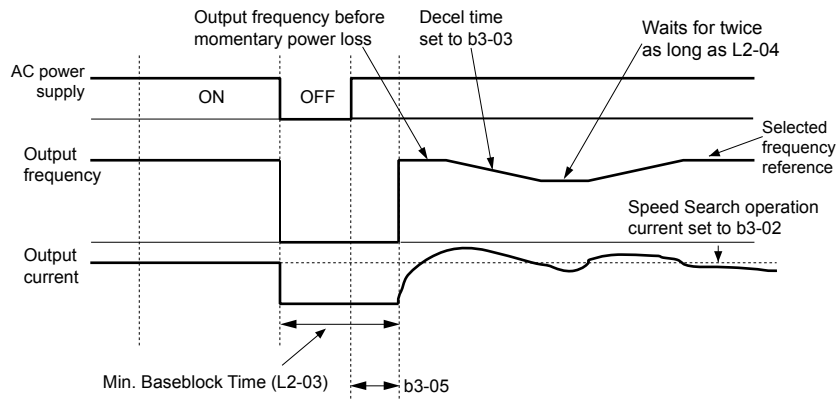

**Figure 1.16 Current Detection Speed Search after Power Loss**

**Note:** After power is restored, the drive waits until the time set to b3-05 has passed before performing Speed Search. Thereby the Speed Search may start not at the end of L2-03 but even later.

When Speed Search is applied automatically with the Run command, the drive waits for the minimum baseblock time set to L2-03 before starting Speed Search. If L2-03 is lower than the time set to parameter b3-05, then b3-05 is used as the wait time.

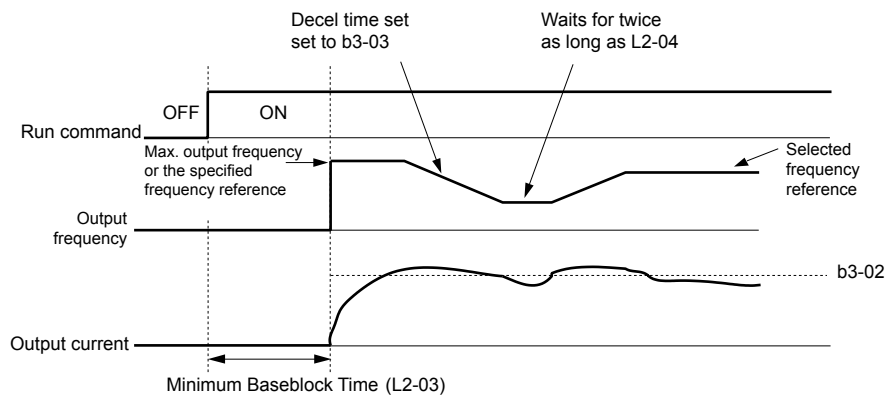

**Figure 1.17 Current Detection Speed Search at Start or Speed Search Command by Digital Input**

### Notes on Using Current Detection Type Speed Search

- Shorten the Speed Search deceleration time set to b3-03 if an oL1 fault occurs while performing Current Detection Speed Search.
- Current Detection Speed Search is not available when using OLV Control for PM motors.
- Increase the minimum baseblock time set to L2-03 if an overcurrent or overvoltage fault occurs when performing Speed Search after power is restored following a momentary power loss.

### ■ Speed Estimation Type Speed Search (b3-24 = 1)

This method can be used for a single induction motor connected to a drive. Do not use this method if the motor is one or more frame size smaller than the drive, at motor speeds above 200 Hz, or when using a single drive to operate more than one motor.

Speed Estimation is executed in the two steps described below:

#### Step 1: Back EMF Voltage Estimation

This method is used by Speed Search after baseblock (e.g., a power loss where the drive CPU continued to run and the Run command was kept active). Here, the drive estimates the motor speed by analyzing the back EMF voltage and outputs the estimated frequency and increases the voltage using the time constant set in parameter L2-04. After that, the motor is accelerated or decelerated to the frequency reference starting from the detected speed. If there is not enough residual voltage in the motor windings to perform the calculations described above, the drive will automatically proceed to step 2.

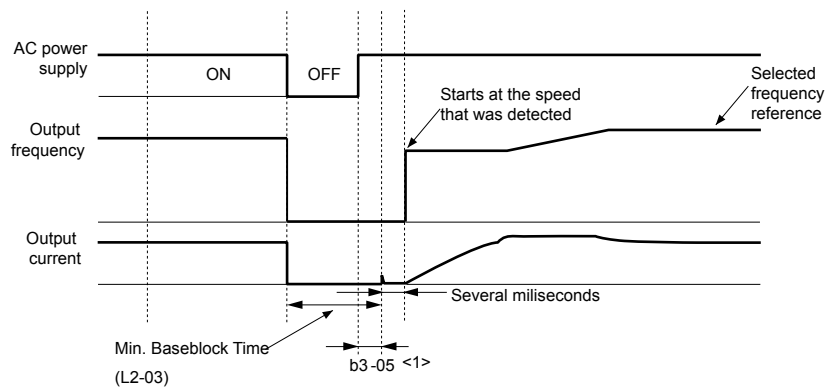

**Figure 1.18 Speed Search after Baseblock**

<1> After AC power is restored, the drive will wait for at least the time set to b3-05. If the power interruption is longer than the minimum baseblock time set to L2-03, the drive will wait until the time set to b3-05 has passed after power is restored before starting Speed Search.

### Step 2: Current Injection

Current Injection is performed when there is insufficient residual voltage in the motor after extended power losses, when Speed Search is applied with the Run command (b3-01 = 1), or when an External search command is used.

This feature injects the amount of DC current set to b3-06 to the motor and detects the speed by measuring the current feedback. The drive then outputs the detected frequency and increases the voltage using the time constant set to parameter L2-04 while looking at the motor current.

The output frequency is reduced if the current is higher than the level in b3-02. When the current falls below b3-02, the motor speed is assumed to be found and the drive starts to accelerate or decelerate to the frequency reference.

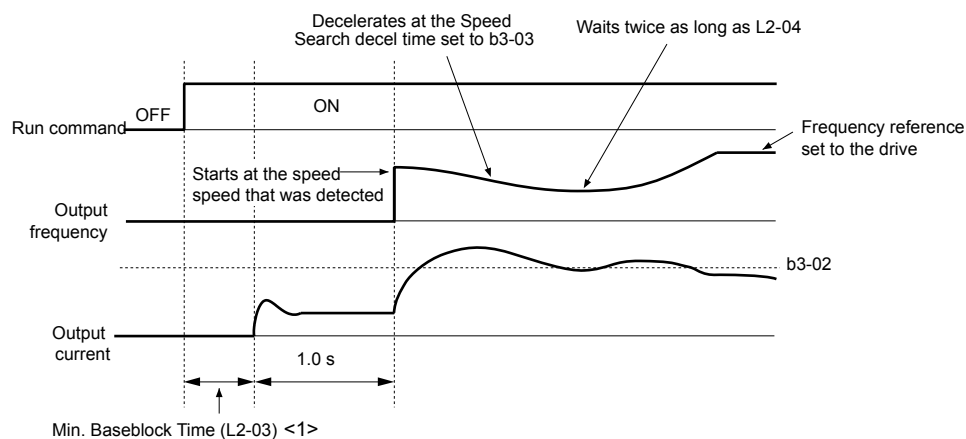

**Figure 1.19 Speed Search at Start**

<1> The wait time for Speed Search (b3-05) determines the lower limit.

### Notes on Using Speed Estimation Speed Search

- Perform Rotational Auto-Tuning for V/f Control (T1-01 = 3) prior to using Speed Estimation in V/f Control and perform Stationary Auto-Tuning for Line-to-Line Resistance (T1-01 = 2) again if there is a change in the cable length between the drive and motor.
- Use Current Detection to search for speeds beyond 200 Hz if the application is running multiple motors from the same drive or if the motor is considerably smaller than the capacity of the drive.
- Speed Estimation may have trouble finding the actual speed if the motor cable is very long. Use Current Detection in these instances.
- Use Current Detection instead of Speed Estimation when operating motors smaller than 1.5 kW because Speed Estimation might not be able to detect the speed or rotation of these smaller motors, in which case Speed Estimation would stop the motor.
- Use Short Circuit Braking instead of Speed Search when using OLV/PM and AOLV/PM with a long motor cable.

## 1.2 b: Application

- Use Short Circuit Braking instead of Speed Search when attempting to find the speed of a motor coasting faster than 200 Hz in OLV/PM and AOLV/PM.

### ■ Speed Search Activation

Speed Search can be activated using any of the methods 1 through 5 described below. The Speed Search type must be selected in parameter b3-24 independent of the activation method.

**Method 1.** Automatically activate Speed Search with every Run command. External Speed Search commands are ignored.

**Method 2.** Activate Speed Search using the digital input terminals.

Use the input functions for H1-□□ in [Table 1.17](#).

**Table 1.17 Speed Search Activation by Digital Inputs**

Setting	Description	b3-24 = 0	b3-24 = 1
61	External Search Command 1	Closed: Activate Current Detection Speed Search from the maximum output frequency (E1-04).	Activate Speed Estimation Speed Search
62	External Search Command 2	Closed: Activate Current Detection Speed Search from the frequency reference.	

To activate Speed Search by a digital input, the input must be set together with the Run command or the Run command must be entered after giving the Speed Search command.

**Method 3.** After automatic fault restart.

When the number of maximum fault restarts in parameter L5-01 is set higher than 0, the drive will automatically perform Speed Search as specified by b3-24 following a fault.

**Method 4.** After momentary power loss.

This mode requires that the Power Loss Ride-Thru function is enabled during CPU operation (L2-01 = 1 or 2). [Refer to L2-01: Momentary Power Loss Operation Selection on page 132.](#)

**Method 5.** After external baseblock is released.

The drive will resume the operation starting with Speed Search if the Run command is present and the output frequency is above the minimum frequency when the Baseblock command (H1-□□ = 8 or 9) is released. For this operation mode, set the operation during an external Baseblock command to hold the output frequency (H1-13 = 0).

### ■ b3-01: Speed Search Selection at Start

Determines if Speed Search is automatically performed when a Run command is issued.

No.	Parameter Name	Setting Range	Default
b3-01	Speed Search Selection at Start	0, 1	Determined by A1-02

#### Setting 0: Disabled

This setting starts operating the drive at the minimum output frequency when the Run command is entered. If external Speed Search 1 or 2 is already enabled by a digital input, the drive will start operating with Speed Search.

#### Setting 1: Enabled

This setting performs Speed Search when the Run command is entered. The drive begins running the motor once Speed Search is complete.

### ■ b3-02: Speed Search Deactivation Current

Sets the operating current for Speed Search as a percentage of the drive rated current. Normally there is no need to change this setting. Lower this value if the drive has trouble restarting.

No.	Name	Setting Range	Default
b3-02	Speed Search Deactivation Current	0 to 200%	Determined by A1-02

**Note:** When parameter A1-02 = 0 (V/f Control) the factory default setting is 120. When parameter A1-02 = 2 (Open Loop Vector) the factory default setting is 100.

### ■ b3-03: Speed Search Deceleration Time

Sets the output frequency reduction ramp used by Current Detection Speed Search (b3-24 = 0) and by the Current Injection Method of Speed Estimation (b3-24 = 1). The time entered into b3-03 will be the time to decelerate from maximum frequency (E1-04) to minimum frequency (E1-09).

No.	Name	Setting Range	Default
b3-03	Speed Search Deceleration Time	0.1 to 10.0 s	2.0 s

### ■ b3-04: V/f Gain During Speed Search

During Speed Search, the output voltage calculated from the V/f pattern is multiplied with this value. Changing this value can help reduce the output current during Speed Search.

No.	Name	Setting Range	Default
b3-04	V/f Gain During Speed Search	10 to 100%	Determined by o2-04

**Note:** Available control modes for parameter b3-04 vary by drive model:  
 CIMR-A□2A0004 to 2A0415 and 4A0002 to 4A0675: Available when A1-02 = 0, 1.  
 CIMR-A□4A0930 to 4A1200 and A1000 HHP : Available when A1-02 = 0.

### ■ b3-05: Speed Search Delay Time

In cases where an output contactor is used between the drive and the motor, the contactor must be closed before Speed Search can be performed. This parameter can be used to delay the Speed Search operation, giving the contactor enough time to close completely.

No.	Name	Setting Range	Default
b3-05	Speed Search Delay Time	0.0 to 100.0 s	0.2 s

### ■ b3-06: Output Current 1 During Speed Search

Sets the current injected to the motor at the beginning of Speed Estimation Speed Search as a factor of the motor rated current set in E2-01 (E4-01 for motor 2). If the motor speed is relatively slow when the drive starts to perform Speed Search after a long period of baseblock, it may be helpful to increase the setting value. The output current during Speed Search is automatically limited by the drive rated current.

No.	Name	Setting Range	Default
b3-06	Output Current 1 during Speed Search	0.0 to 2.0	Determined by o2-04

**Note:** Use Current Detection Speed Search if Speed Estimation is not working correctly even after adjusting b3-06.

### ■ b3-10: Speed Search Detection Compensation Gain

Sets the gain for the detected motor speed of the Speed Estimation Speed Search. Increase the setting only if an overvoltage fault occurs when the drive restarts the motor.

No.	Name	Setting Range	Default
b3-10	Speed Search Detection Compensation Gain	1.00 to 1.20	1.05

### ■ b3-14: Bi-Directional Speed Search Selection

Sets how the drive determines the motor rotation direction when performing Speed Estimation Speed Search.

No.	Parameter Name	Setting Range	Default
b3-14	Bi-Directional Speed Search Selection	0, 1	Determined by A1-02

#### Setting 0: Disabled

The drive uses the frequency reference to determine the direction of motor rotation to restart the motor.

#### Setting 1: Enabled

The drive detects the motor rotation direction to restart the motor.

## 1.2 b: Application

### ■ b3-17: Speed Search Restart Current Level

Sets the current level at which Speed Estimation is restarted as a percentage of drive rated current to avoid overcurrent and overvoltage problems since a large current can flow into the drive if the difference between the estimated frequency and the actual motor speed is too big when performing Speed Estimation.

No.	Name	Setting Range	Default
b3-17	Speed Search Restart Current Level	0 to 200%	150%

### ■ b3-18: Speed Search Restart Detection Time

Sets the time for which the current must be above the level set in b3-17 before restarting Speed Search.

No.	Name	Setting Range	Default
b3-18	Speed Search Restart Detection Time	0.00 to 1.00 s	0.10 s

### ■ b3-19: Number of Speed Search Restarts

Sets the number of times the drive should attempt to find the speed and restart the motor. If the number of restart attempts exceeds the value set to b3-19, the SEr fault will occur and the drive will stop.

No.	Name	Setting Range	Default
b3-19	Number of Speed Search Restarts	0 to 10	3

### ■ b3-24: Speed Search Method Selection

Sets the Speed Search method used.

No.	Parameter Name	Setting Range	Default
b3-24	Speed Search Method Selection	0, 1	0

#### Setting 0: Current Detection Speed Search

#### Setting 1: Speed Estimation Speed Search

Note: Refer to [Current Detection Speed Search \(b3-24 = 0\)](#) on page 27 and [Speed Estimation Type Speed Search \(b3-24 = 1\)](#) on page 28 for explanations of the Speed Search methods.

### ■ b3-25: Speed Search Wait Time

Sets the wait time between Speed Search restarts. Increase the wait time if problems occur with overcurrent, overvoltage, or if the SEr fault occurs.

No.	Name	Setting Range	Default
b3-25	Speed Search Wait Time	0.0 to 30.0 s	0.5 s

## ◆ b4: Delay Timers

The timer function is independent of drive operation and can delay the switching of a digital output triggered by a digital input signal and help eliminate chattering switch noise from sensors. An on-delay and off-delay can be set separately.

To enable the timer function, set a multi-function input to “Timer input” (H1-□□ = 18) and set a multi-function output to “Timer output” (H2-□□ = 12). Only one timer can be used.

### ■ b4-01, b4-02: Timer Function On-Delay, Off-Delay Time

b4-01 sets the on-delay time for switching the timer output. b4-02 sets the off-delay time for switching the timer output.

No.	Name	Setting Range	Default
b4-01	Timer Function On-Delay Time	0.0 to 3000.0 s	0.0 s
b4-02	Timer Function Off-Delay Time	0.0 to 3000.0 s	0.0 s

### ■ Timer Function Operation

The timer function switches on when the timer function input closes for longer than the value set to b4-01. The timer function switches off when the timer function input is open for longer than the value set to b4-02. The following diagram illustrates the timer function operation:



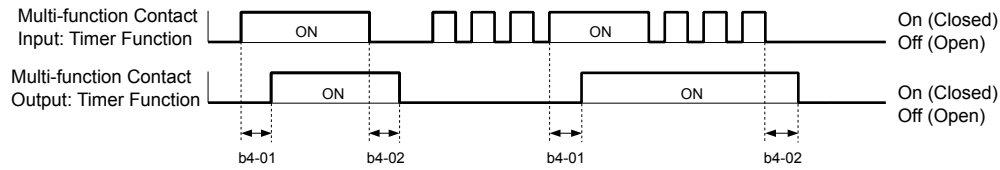

Figure 1.20 Timer Operation

## ◆ b5: PID Control

The drive has a built-in Proportional + Integral + Derivative (PID) controller that uses the difference between the target value and the feedback value to adjust the drive output frequency to minimize deviation and provide accurate closed loop control of system variables such as pressure or temperature.

### ■ P Control

The output of P control is the product of the deviation and the P gain so that it follows the deviation directly and linearly. With P control, only an offset between the target and feedback remains.

### ■ I Control

The output of I control is the integral of the deviation. It minimizes the offset between target and feedback value that typically remains when pure P control is used. The integral time (I time) constant determines how fast the offset is eliminated.

### ■ D Control

D control predicts the deviation signal by multiplying its derivative (slope of the deviation) with a time constant, then adds this value to the PID input. This way the D portion of a PID controller provides a braking action to the controller response and can reduce the tendency to oscillate and overshoot.

D control tends to amplify noise on the deviation signal, which can result in control instability. Only use D control when absolutely necessary.

### ■ PID Operation

To better demonstrate PID functionality, the diagram below illustrates how the PID output changes when the PID input (deviation) jumps from 0 to a constant level.

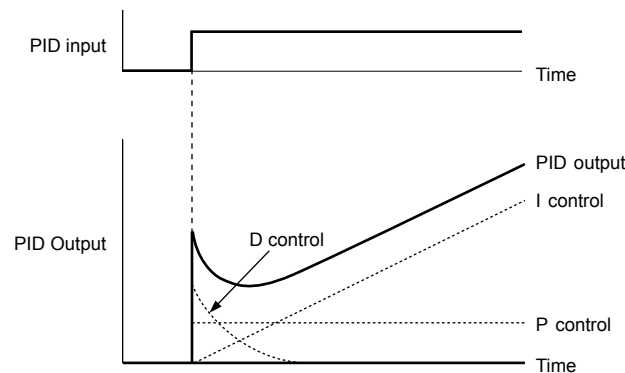

Figure 1.21 PID Operation

### ■ Using PID Control

Applications for PID control are listed in the following table.

Application	Description	Sensors Used
Speed Control	Machinery speed is fed back and adjusted to meet the target value. Synchronous control is performed using speed data from other machinery as the target value	Tachometer
Pressure	Maintains constant pressure using pressure feedback.	Pressure sensor
Fluid Control	Keeps flow at a constant level by feeding back flow data.	Flow rate sensor
Temperature Control	Maintains a constant temperature by controlling a fan with a thermostat.	Thermocoupler, Thermistor

## 1.2 b: Application

### ■ PID Setpoint Input Methods

The PID setpoint input depends on the PID function setting in parameter b5-01.

If parameter b5-01 is set to 1 or 2, the frequency reference in b1-01 (or b1-15) or one of the inputs listed in [Table 1.18](#) becomes the PID setpoint.

If b5-01 is set to 3 or 4, then the PID setpoint can be input from one of the sources listed in [Table 1.18](#).

**Table 1.18 PID Setpoint Sources**

PID Setpoint Source	Settings
Analog Input A1	Set H3-02 = C
Analog Input A2	Set H3-10 = C
Analog Input A3	Set H3-06 = C
MEMOBUS/Modbus Register 0006 H	Set bit 1 in register 000F H to 1 and input the setpoint to register 0006 H
Pulse Input RP	Set H6-01 = 2
Parameter b5-19	Set parameter b5-18 = 1 and input the PID setpoint to b5-19

**Note:** A duplicate allocation of the PID setpoint input will cause an oPE alarm.

### ■ PID Feedback Input Methods

Input one feedback signal for normal PID control or input two feedback signals can for controlling a differential process value.

#### Normal PID Feedback

Input the PID feedback signal from one of the sources listed below:

**Table 1.19 PID Feedback Sources**

PID Feedback Source	Settings
Analog Input A1	Set H3-02 = B
Analog Input A2	Set H3-10 = B
Analog Input A3	Set H3-06 = B
Pulse Input RP	Set H6-01 = 1

**Note:** A duplicate allocation of the PID feedback input will cause an oPE alarm.

#### Differential Feedback

The second PID feedback signal for differential feedback can come from the sources listed below. The differential feedback function is automatically enabled when a differential feedback input is assigned.

**Table 1.20 PID Differential Feedback Sources**

PID Differential Feedback Source	Settings
Analog Input A1	Set H3-02 = 16
Analog Input A2	Set H3-10 = 16
Analog Input A3	Set H3-06 = 16

**Note:** A duplicate allocation of the PID differential feedback input will cause an oPE alarm.

■ PID Block Diagram

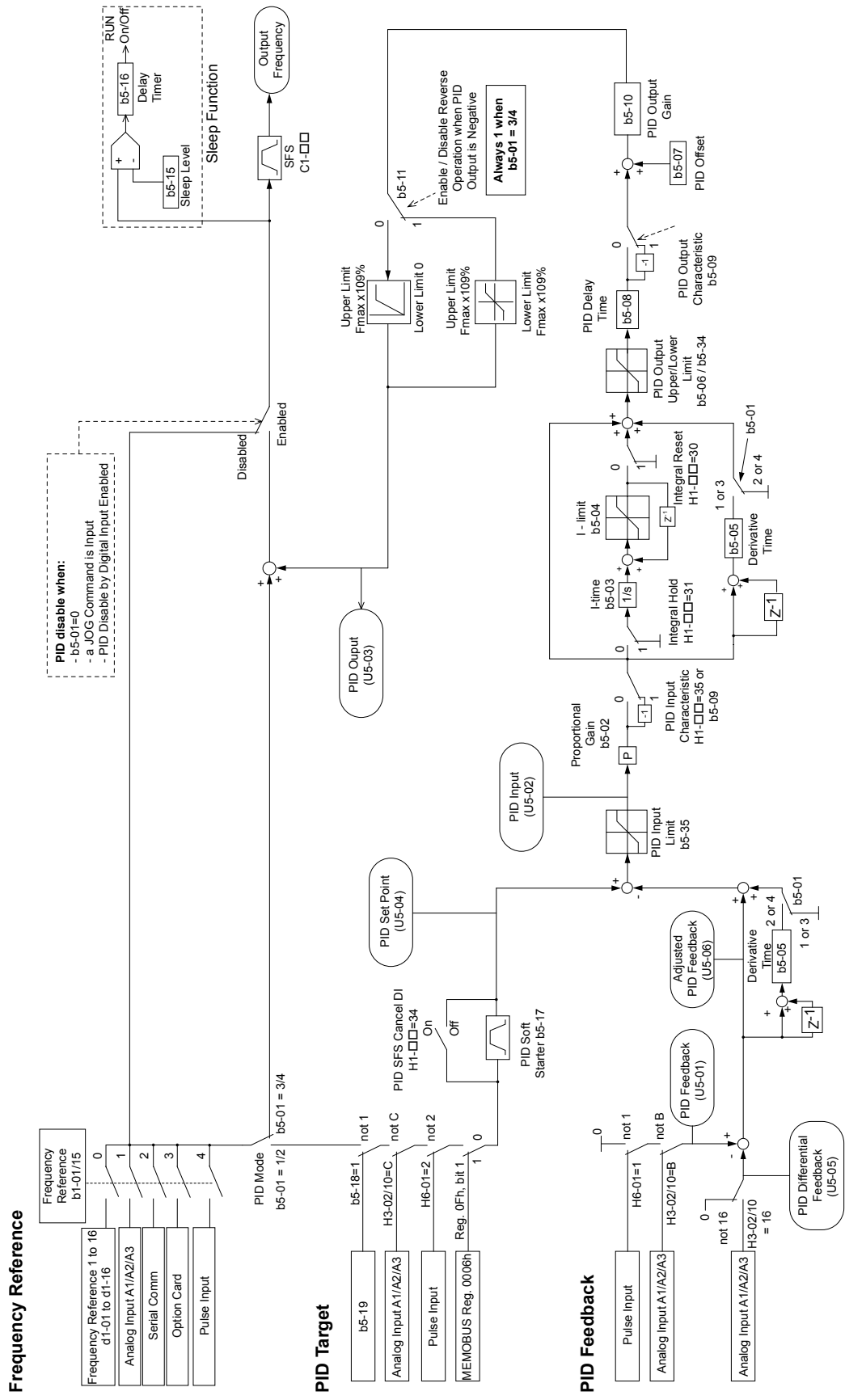

Figure 1.22 PID Block Diagram

## 1.2 b: Application

### ■ b5-01: PID Function Setting

Enables or disables the PID operation and selects the PID operation mode.

No.	Parameter Name	Setting Range	Default
b5-01	PID Function Setting	0 to 4	0

#### Setting 0: PID disabled

#### Setting 1: Output frequency = PID output 1

The PID controller is enabled and the PID output builds the frequency reference. The PID input is D controlled.

#### Setting 2: Output frequency = PID output 2

The PID controller is enabled and the PID output builds the frequency reference. The PID feedback is D controlled.

#### Setting 3: Output frequency = frequency reference + PID output 1

The PID controller is enabled and the PID output is added to the frequency reference. The PID input is D controlled.

#### Setting 4: Output frequency = frequency reference + PID output 2

The PID controller is enabled and the PID output is added to the frequency reference. The PID feedback is D controlled.

### ■ b5-02: Proportional Gain Setting (P)

Sets the P gain applied to the PID input. Larger values will tend to reduce the error but may cause oscillations if set too high, while lower values may allow too much offset between the setpoint and feedback.

No.	Name	Setting Range	Default
b5-02	Proportional Gain Setting (P)	0.00 to 25.00	1.00

### ■ b5-03: Integral Time Setting (I)

Sets the time constant used to calculate the integral of the PID input. The shorter the integral time set to b5-03, the faster the offset will be eliminated. If the integral time is set too short, however, overshoot or oscillation may occur. To turn off the integral time, set b5-03 to 0.00.

No.	Name	Setting Range	Default
b5-03	Integral Time Setting (I)	0.0 to 360.0 s	1.0 s

### ■ b5-04: Integral Limit Setting

Sets the maximum output possible from the integral block as a percentage of the maximum frequency (E1-04).

No.	Name	Setting Range	Default
b5-04	Integral Limit Setting	0.0 to 100.0%	100.0%

**Note:** On some applications, especially those with rapidly varying loads, the output of the PID function may show a fair amount of oscillation. Program b5-04 to apply a limit to the integral output and suppress this oscillation.

### ■ b5-05: Derivative Time (D)

Sets the time the drive predicts the PID input/PID feedback signal based on the derivative of the PID input/PID feedback. Longer time settings improve the response but can cause vibrations, while shorter time settings reduce the overshoot but reduce controller responsiveness. D control is disabled by setting b5-05 to zero seconds.

No.	Name	Setting Range	Default
b5-05	Derivative Time (D)	0.00 to 10.00 s	0.00 s

### ■ b5-06: PID Output Limit

Sets the maximum output possible from the entire PID controller as a percentage of the maximum frequency (E1-04).

No.	Name	Setting Range	Default
b5-06	PID Output Limit	0.0 to 100.0%	100.0%

### ■ b5-07: PID Offset Adjustment

Sets the offset added to the PID controller output as a percentage of the maximum frequency (E1-04).

No.	Name	Setting Range	Default
b5-07	PID Offset Adjustment	-100.0 to 100.0%	0.0%

### ■ b5-08: PID Primary Delay Time Constant

Sets the time constant for the filter applied to the output of the PID controller. Normally, change is not required.

No.	Name	Setting Range	Default
b5-08	PID Primary Delay Time Constant	0.00 to 10.00 s	0.00 s

**Note:** Useful when there is a fair amount of oscillation or when rigidity is low. Set to a value larger than the cycle of the resonant frequency. Increasing this time constant may reduce the responsiveness of the drive.

### ■ b5-09: PID Output Level Selection

Reverses the sign of the PID controller output signal. Normally a positive PID input (feedback smaller than setpoint) leads to positive PID output.

No.	Parameter Name	Setting Range	Default
b5-09	PID Output Level Selection	0, 1	0

#### Setting 0: Normal Output

A positive PID input causes an increase in the PID output (direct acting).

#### Setting 1: Reverse Output

A positive PID input causes a decrease in the PID output (reverse acting).

### ■ b5-10: PID Output Gain Setting

Applies a gain to the PID output and can be helpful when the PID function is used to trim the frequency reference (b5-01 = 3 or 4).

No.	Name	Setting Range	Default
b5-10	PID Output Gain Setting	0.00 to 25.00	1.00

### ■ b5-11: PID Output Reverse Selection

Determines whether a negative PID output reverses the direction of drive operation. This parameter has no effect when the PID function trims the frequency reference (b5-01 = 3 or 4) and the PID output will not be limited (same as b5-11 = 1).

No.	Parameter Name	Setting Range	Default
b5-11	PID Output Reverse Selection	0, 1	0

#### Setting 0: Reverse Disabled

Negative PID output will be limited to 0 and the drive output will be stopped.

#### Setting 1: Reverse Enabled

Negative PID output will cause the drive to run in the opposite direction.

### ■ PID Feedback Loss Detection

The PID feedback loss detection function detects broken sensors or broken sensor wiring. It should be used when PID control is enabled to prevent critical machine conditions (e.g., acceleration to max. frequency) caused by a feedback loss.

Feedback loss can be detected in two ways:

- **Feedback Low Detection**

Detected when the feedback falls below a certain level for longer than the specified time. This function is set up using parameters b5-12 to b5-14.

- **Feedback High Detection**

Detected when the feedback rises above a certain level for longer than the specified time. This function is set up using parameters b5-12, b5-36, and b5-37.

The following figure illustrates the working principle of feedback loss detection when the feedback signal is too low. Feedback high detection works in the same way.

## 1.2 b: Application

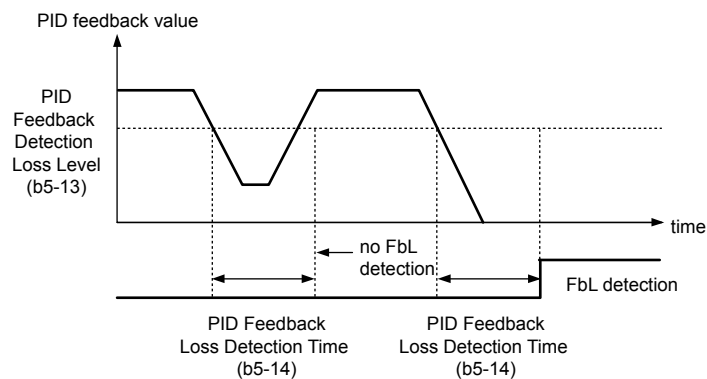

Figure 1.23 PID Feedback Loss Detection

### ■ b5-12: PID Feedback Loss Detection Selection

Enables or disables the feedback loss detection and sets the operation when a feedback loss is detected.

No.	Parameter Name	Setting Range	Default
b5-12	PID Feedback Loss Detection Selection	0 to 5	0

#### Setting 0: Digital Output Only

A digital output set for “PID feedback low” (H2-□□ = 3E) will be triggered if the PID feedback value is below the detection level set to b5-13 for the time set to b5-14 or longer. A digital output set for “PID feedback high” (H2-□□ = 3F) will be triggered if the PID feedback value is beyond the detection level set to b5-36 for longer than the time set to b5-37. Neither a fault nor an alarm is displayed on the digital operator and the drive will continue operation. The output resets when the feedback value leaves the loss detection range.

#### Setting 1: Feedback Loss Alarm

If the PID feedback value falls below the level set to b5-13 for longer than the time set to b5-14, a “FBL - Feedback Low” alarm will be displayed and a digital output set for “PID feedback low” (H2-□□ = 3E) will be triggered. If the PID feedback value exceeds the level set to b5-36 for longer than the time set to b5-37, a “FBH - Feedback High” alarm will be displayed and a digital output set for “PID feedback high” (H2-□□ = 3F) will be triggered. Both events trigger an alarm output (H1-□□ = 10). The drive will continue operation. The alarm and outputs reset when the feedback value leaves the loss detection range.

#### Setting 2: Feedback Loss Fault

If the PID feedback value falls below the level set to b5-13 for longer than the time set to b5-14, a “FbL - Feedback Low” fault will be displayed. If the PID feedback value exceeds the level set to b5-36 for longer than the time set to b5-37, a “FbH - Feedback High” fault will be displayed. Both events trigger a fault output (H1-□□ = E) and cause the drive to stop the motor.

#### Setting 3: Digital output only, even if PID is disabled by digital input

Same as b5-12 = 0. Detection remains active when PID is disabled by a digital input (H1-□□ = 19).

#### Setting 4: Feedback loss alarm, even if PID is disabled by digital input

Same as b5-12 = 1. Detection remains active when PID is disabled by a digital input (H1-□□ = 19).

#### Setting 5: Feedback loss fault, even if PID is disabled by digital input

Same as b5-12 = 2. Detection remains active when PID is disabled by a digital input (H1-□□ = 19).

### ■ b5-13: PID Feedback Low Detection Level

Sets the feedback level used for PID feedback low detection. The PID feedback must fall below this level for longer than the time set to b5-14 before feedback loss is detected.

No.	Name	Setting Range	Default
b5-13	PID Feedback Low Detection Level	0 to 100%	0%

### ■ b5-14: PID Feedback Low Detection Time

Sets the time that the PID feedback has to fall below b5-13 before feedback loss is detected.

No.	Name	Setting Range	Default
b5-14	PID Feedback Low Detection Time	0.0 to 25.5 s	1.0 s

### ■ b5-36: PID Feedback High Detection Level

Sets the feedback level used for PID feedback high detection. The PID feedback must exceed this level for longer than the time set to b5-37 before feedback loss is detected.

No.	Name	Setting Range	Default
b5-36	PID Feedback High Detection Level	0 to 100%	100%

### ■ b5-37: PID Feedback High Detection Time

Sets the time that the PID feedback must exceed the value set to b5-36 before feedback loss is detected.

No.	Name	Setting Range	Default
b5-37	PID Feedback High Detection Time	0.0 to 25.5 s	1.0 s

### ■ PID Sleep

The PID Sleep function stops the drive when the PID output or the frequency reference falls below the PID Sleep operation level for a certain time. The drive will resume operating when the PID output or frequency reference rise above the PID Sleep operation level for the specified time. An example of PID Sleep operation appears in the figure below.

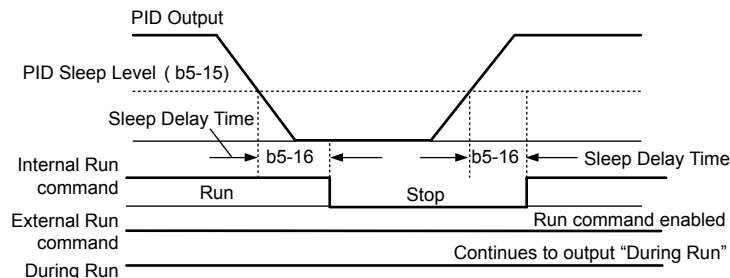

Figure 1.24 PID Sleep Operation

#### Notes on using the PID Sleep function

- The PID Sleep function is active even when PID control is disabled.
- The PID Sleep function stops the motor according to the stopping method set to b1-03.

The parameters necessary to control the PID Sleep function are explained below.

### ■ b5-15: PID Sleep Function Start Level

Sets the level that triggers PID Sleep.

The drive goes into Sleep mode if the PID output or frequency reference is smaller than b5-15 for longer than the time set to b5-16. The drive resumes operation when the PID output or frequency reference is above b5-15 for longer than the time set to b5-16.

No.	Name	Setting Range	Default
b5-15	PID Sleep Function Start Level	0.0 to 400.0 Hz	0.0 Hz

### ■ b5-16: PID Sleep Delay Time

Sets the delay time to activate or deactivate the PID Sleep function.

No.	Name	Setting Range	Default
b5-16	PID Sleep Delay Time	0.0 to 25.5 s	0.0 s

### ■ b5-17: PID Accel/Decel Time

The PID acceleration/deceleration time is applied on the PID setpoint value.

When the setpoint changes quickly, the normal C1-□□ acceleration times reduce the responsiveness of the system as they are applied after the PID output. The PID accel/decel time helps avoid the hunting and overshoot and undershoot that can result from the reduced responsiveness.

## 1.2 b: Application

The PID acceleration/deceleration time can be canceled using a digital input programmed for “PID SFS cancel” (H1-□□ = 34).

No.	Name	Setting Range	Default
b5-17	PID Accel/Decel Time	0.0 to 6000.0 s	0.0 s

### ■ b5-18: PID Setpoint Selection

Enables or disables parameter b5-19 for PID setpoint.

No.	Parameter Name	Setting Range	Default
b5-18	PID Setpoint Selection	0, 1	0

#### Setting 0: Disabled

Parameter b5-19 is not used as the PID setpoint.

#### Setting 1: Enabled

Parameter b5-19 is used as PID setpoint.

### ■ b5-19: PID Setpoint Value

Used as the PID setpoint if parameter b5-18 = 1.

No.	Name	Setting Range	Default
b5-19	PID Setpoint Value	0.00 to 100.00%	0.00%

### ■ b5-20: PID Setpoint Scaling

Determines the units for the PID Setpoint Value (b5-19) and monitors U5-01 and U5-04.

No.	Parameter Name	Setting Range	Default
b5-20	PID Setpoint Scaling	0 to 3	1

#### Setting 0: Hz

The setpoint and PID monitors are displayed in Hz with a resolution of 0.01 Hz.

#### Setting 1: %

The setpoint and PID monitors are displayed as a percentage with a resolution of 0.01%.

#### Setting 2: r/min

The setpoint and PID monitors are displayed in r/min with a resolution of 1 r/min.

#### Setting 3: User Defined

Parameters b5-38 and b5-39 determine the units and resolution used to display the values the setpoint in b5-19, and PID monitors U1-01 and U1-04.

### ■ b5-34: PID Output Lower Limit

Sets the minimum possible PID controller output as a percentage of the maximum output frequency (E1-04). The lower limit is disabled when set to 0.00%

No.	Name	Setting Range	Default
b5-34	PID Output Lower Limit	-100.0 to 100.0%	0.00%

### ■ b5-35: PID Input Limit

Sets the maximum allowed PID input as a percentage of the maximum output frequency (E1-04). Parameter b5-35 acts as a bipolar limit.

No.	Name	Setting Range	Default
b5-35	PID Input Limit	0 to 1000.0%	1000.0%

### ■ b5-38, b5-39: PID Setpoint User Display, PID Setpoint Display Digits

When parameter b5-20 is set to 3, parameters b5-38 and b5-39 set a user-defined display for the PID setpoint (b5-19) and PID feedback monitors (U5-01, U5-04).



Parameter b5-38 determines the display value when the maximum frequency is output and parameter b5-39 determines the number of digits. The setting value is equal to the number of decimal places.

No.	Name	Setting Range	Default
b5-38	PID Setpoint User Display	1 to 60000	Determined by b5-20
b5-39	PID Setpoint Display Digits	0 to 3	Determined by b5-20

### ■ b5-40: Frequency Reference Monitor Content During PID

Sets the content of the frequency reference monitor display (U1-01) when PID control is active.

No.	Name	Setting Range	Default
b5-40	Frequency Reference Monitor Content During PID	0, 1	0

#### Setting 0: Frequency Reference after PID

Monitor U1-01 displays the frequency reference increased or reduced for the PID output.

#### Setting 1: Frequency Reference

Monitor U1-01 displays the frequency reference value.

## 1.2 b: Application

### ■ Fine-Tuning PID

Follow the directions below to fine tune PID control parameters:

**Table 1.21 PID Fine Tuning**

Goal	Tuning Procedure	Result
Suppress overshoot	<ul style="list-style-type: none"> <li>• Reduce the derivative time (b5-05)</li> <li>• Increase the integral time (b5-03)</li> </ul>	
Achieve stability quickly while allowing some overshoot	<ul style="list-style-type: none"> <li>• Decrease the integral time (b5-03)</li> <li>• Increase the derivative time (b5-05)</li> </ul>	
Suppress long cycle oscillations (longer than the integral time setting)	Increase the integral time (b5-03)	
Suppress short cycle oscillations	<ul style="list-style-type: none"> <li>• If oscillation cycle time is close to the derivative time, reduce the derivative time (b5-05).</li> <li>• If the derivative time is set to 0.00 s and oscillations are still a problem, reduce the proportional gain (b5-02) or increase the PID primary delay time (b5-08)</li> </ul>	

### ◆ b6: Dwell Function

The Dwell function temporarily holds the frequency reference at a predefined value for a set time then continues accelerating or decelerating.

The Dwell function helps prevent speed loss when starting and stopping a heavy load with induction motors. When running a PM motor in V/f control, the pause in acceleration allows the PM motor rotor to align with the stator field of the motor and reduce the starting current.

The figure below illustrates how the Dwell function works.

**Note:** Set the stopping method to "Ramp to Stop" (b1-03 = 0) to use the Dwell function.

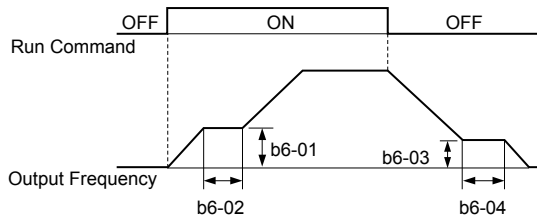

Figure 1.25 Dwell Function at Start and Stop

■ **b6-01, b6-02: Dwell Reference, Dwell Time at Start**

Parameter b6-01 determines the frequency that is held for the time set in b6-02 during acceleration.

No.	Name	Setting Range	Default
b6-01	Dwell Reference at Start	0.0 to 400.0 Hz	0.0 Hz
b6-02	Dwell Time at Start	0.0 to 10.0 s	0.0 s

■ **b6-03, b6-04: Dwell Reference, Dwell Time at Stop**

Parameter b6-03 determines the frequency that is held for the time set in b6-04 during deceleration.

No.	Name	Setting Range	Default
b6-03	Dwell Reference at Stop	0.0 to 400.0 Hz	0.0 Hz
b6-04	Dwell Time at Stop	0.0 to 10.0 s	0.0 s

◆ **b7: Droop Control (CLV, CLV/PM)**

**Note:** PM motor control modes are not available in A1000 HHP drive models.

Droop control automatically balances the load level between two motors driving the same load. Droop control must be activated in one of the drives controlling these motors. The drive in which Droop control is activated shifts the load from one motor to another by automatically reducing the speed when the torque reference rises, and automatically increasing the speed when the torque reference falls.

**Note:** Disable Feed Forward (n5-01 = 0) whenever using Droop control.

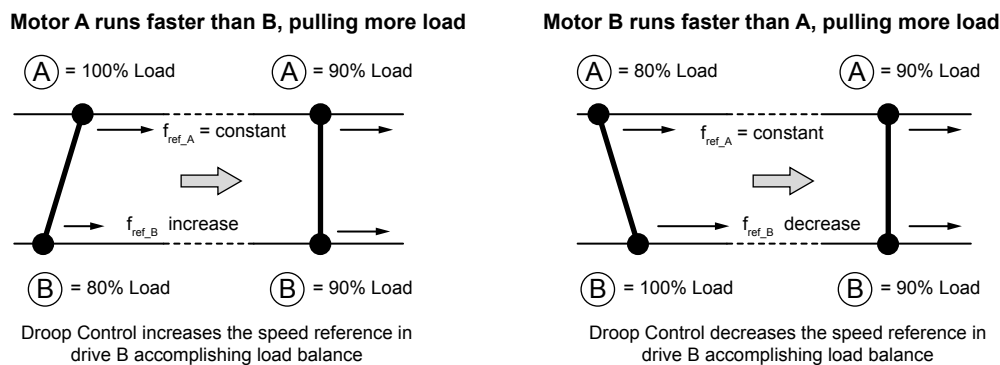

Figure 1.26 Droop Control Application

■ **b7-01: Droop Control Gain**

Sets the amount of speed reduction when the torque reference is 100%. The gain is set as a percentage of the maximum output frequency. A setting of 0.0% disables the Droop control function.

No.	Parameter Name	Setting Range	Default
b7-01	Droop Control Gain	0.0 to 100.0%	0.0%

## 1.2 b: Application

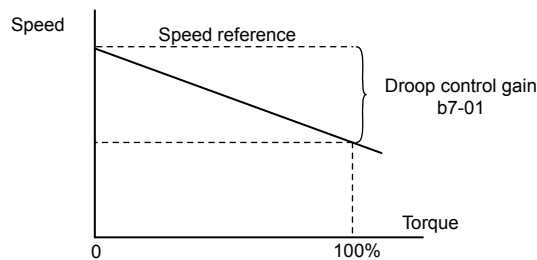

Figure 1.27 Droop Control Gain

### ■ b7-02: Droop Control Delay Time

Adjusts the responsiveness of Droop control. Reduce the setting if the reaction time is too long, and increase the setting if hunting occurs.

No.	Parameter Name	Setting Range	Default
b7-02	Droop Control Delay Time	0.03 to 2.00 s	0.05 s

### ■ b7-03: Droop Control Limit Selection

Enables or disables the droop control limit.

No.	Parameter Name	Setting Range	Default
b7-03	Droop Control Limit Selection	0, 1	1

**Setting 0: Disabled**

**Setting 1: Enabled**

## ◆ b9: Zero Servo

The Zero Servo function is a position loop that can be used in CLV and CLV/PM control modes to lock the motor at a certain position.

To activate Zero Servo mode, use a digital input set for H1-□□ = 72 and the drive will decelerate when this input is closed. The drive goes into Zero Servo mode and holds the current position when the motor speed falls below the level set to parameter b2-01. The drive accelerates when the input assigned to trigger the Zero Servo function is released and the Run command is still present.

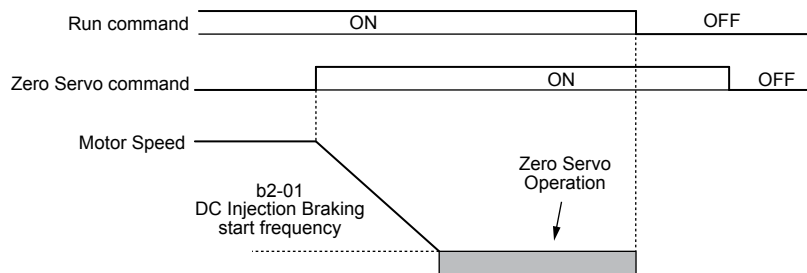

Figure 1.28 Zero Servo Operation

When Zero Servo mode is active, the deviation between the rotor position and the zero position is displayed in monitor U6-22 (monitor value must be divided by 4 to get the deviation in actual encoder pulses).

A digital output programmed for “Zero Servo complete” (H2-□□ = 33) is turned on when the rotor position is within the zero position, plus or minus the Zero Servo completion width set to parameter b9-02.

- Note:**
1. The Run command must remain on when using the Zero Servo function. Zero Servo will not hold the load in place if the Run command is switched off.
  2. When the Zero Servo command has shut off, the Zero Servo Completion digital output width also shuts off.
  3. Avoid using Zero Servo to lock 100% load for long periods, as this can trigger a fault. If such loads need to be held in place for long periods, either make sure the current is less than 50% of the drive rated current during Zero Servo, or use a larger capacity drive.
  4. If the load rotates the motor when using CLV/PM, a dv4 fault may occur. To prevent this, either increase the Zero Servo gain (b9-01) or increase the number of pulses set to F1-19 that are required to trigger dv4.

### ■ b9-01: Zero Servo Gain

Adjusts the responsiveness of the Zero Servo position loop. Increase the value if the response is too slow and the deviation from the zero position rises too high when load is applied. Decrease the value if vibrations occur during Zero Servo operation.

**Note:** Before adjusting the Zero Servo gain, make sure the ASR parameters (C5-□□) are set up properly and vibration or hunting does not occur when running with a zero speed reference.

No.	Name	Setting Range	Default
b9-01	Zero Servo Gain	0 to 100	5

### ■ b9-02: Zero Servo Completion Width

Sets the output range of the Zero Servo completion signal. Enter the amount of deviation allowable from the desired position to trigger Zero Servo. An output terminal set for Zero Servo (H2-□□ = 33) will be triggered when the motor reaches the position Zero Servo plus or minus b9-02.

No.	Name	Setting Range	Default
b9-02	Zero Servo Completion Width	0 to 16383	10

## 1.3 C: Tuning

C parameters set the characteristics for acceleration, deceleration, and S-curves. Other parameters in the C group cover settings for slip compensation, torque compensation, and carrier frequency.

### ◆ C1: Acceleration and Deceleration Times

#### ■ C1-01 to C1-08: Accel, Decel Times 1 to 4

Four different sets of acceleration and deceleration times can be set in the drive by digital inputs, motor selection, or switched automatically.

Acceleration time parameters always set the time to accelerate from 0 Hz to the maximum output frequency (E1-04). Deceleration time parameters always set the time to decelerate from maximum output frequency to 0 Hz. C1-01 and C1-02 are the default active accel/decel settings.

No.	Parameter Name	Setting Range	Default
C1-01	Acceleration Time 1	0.0 to 6000.0 s <1>	10.0 s
C1-02	Deceleration Time 1		
C1-03	Acceleration Time 2		
C1-04	Deceleration Time 2		
C1-05	Acceleration Time 3 (Motor 2 Accel Time 1)		
C1-06	Deceleration Time 3 (Motor 2 Decel Time 1)		
C1-07	Acceleration Time 4 (Motor 2 Accel Time 2)		
C1-08	Deceleration Time 4 (Motor 2 Accel Time 2)		

<1> The setting range for the acceleration and deceleration times is determined by the accel/decel time setting units in C1-10. For example, if the time is set in units of 0.01 s (C1-10 = 0), the setting range becomes 0.00 to 600.00 s.

#### Switching Acceleration Times by Digital Input

Accel/decel times 1 are active by default if no input is set. Activate accel/decel times 2, 3, and 4 by digital inputs (H1-□□ = 7 and 1A) as explained in [Table 1.22](#).

Table 1.22 Accel/Decel Time Selection by Digital Input

Accel/Decel Time Sel. 1 H1-□□ = 7	Accel/Decel Time Sel. 2 H1-□□ = 1A	Active Times	
		Acceleration	Deceleration
0	0	C1-01	C1-02
1	0	C1-03	C1-04
0	1	C1-05	C1-06
1	1	C1-07	C1-08

[Figure 1.29](#) shows an operation example for changing accel/decel. times. The example below requires that the stopping method be set for “Ramp to stop” (b1-03 = 0).

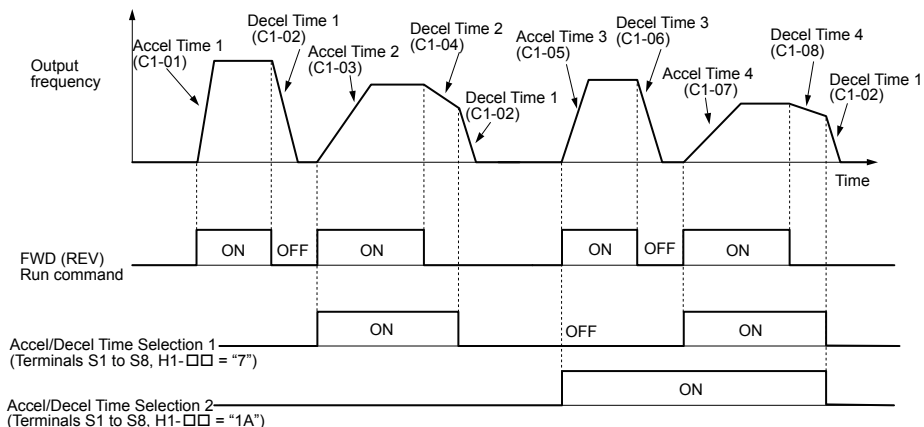

Figure 1.29 Timing Diagram of Accel/Decel Time Change

### Switching Acceleration and Deceleration Times by Motor Selection

When switching between motor 1 and 2 using a digital input (H1-□□ = 16), parameters C1-01 to C1-04 become accel/decel times 1 and 2 for motor 1, while C1-05 to C1-08 become accel/decel times 1 and 2 for motor 2. Accel/decel times 1 and 2 can be switched for each motor using a digital inputs set to H1-□□ = 7 like shown in [Table 1.23](#).

- Note:**
1. The motor 2 selection function cannot be used with PM motors.
  2. Attempting to use the digital input setting “Accel/Decel time 2 selection” (H1-□□ = 1A) together with motor 1/2 switching triggers an oPE03 error, indicating contradictory multifunction input settings.

**Table 1.23 Motor Switching and Accel/Decel Time Combinations**

Accel/Decel Time 1 (H1-□□ = 7)	Motor 1 Selected (Terminal set to H1-□□ = 16 OFF)		Motor 2 Selected (Terminal set to H1-□□ = 16 ON)	
	Accel	Decel	Accel	Decel
Open	C1-01	C1-02	C1-05	C1-06
Closed	C1-03	C1-04	C1-07	C1-08

### Switching Accel/Decel Times by a Frequency Level

The drive can switch between different acceleration and deceleration times automatically. The drive will switch from accel/decel time 4 in C1-07 and C1-08 to the default accel/decel time in C1-01 and C1-02 (C1-05 and C1-06 for motor 2) when the output frequency exceeds the frequency level set to parameter C1-11. When the frequency falls below this level, the accel/decel times are switched back. [Figure 1.30](#) shows an operation example.

- Note:** Acceleration and deceleration times selected by digital inputs have priority over the automatic switching by the frequency level set to C1-11. For example, if accel/decel time 2 is selected, the drive will use only accel/decel time 2; it will not switch from accel/decel time 4 to the selected one.

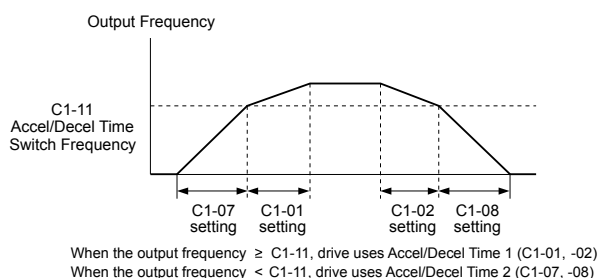

**Figure 1.30 Accel/Decel Time Switching Frequency**

### ■ C1-11: Accel/Decel Time Switching Frequency

Sets the frequency at which the drive switches between accel/decel time settings. See [Refer to Switching Accel/Decel Times by a Frequency Level on page 47](#).

No.	Parameter Name	Setting Range	Default
C1-11	Accel/Decel Time Switching Frequency	0.0 to 400.0 Hz <1>	Determined by A1-02 <1>

<1> In AOLV/PM and CLV/PM control modes, the setting units and range are expressed as a percentage (0.0 to 100.0%) instead of in Hz.

- Note:** Setting C1-11 to 0.0 disables this function.

### ■ C1-09: Fast Stop Time

Sets a special deceleration used when a select group of faults occur (e.g., L8-03 Overheat Pre-Alarm Operation Selection) or when closing a digital input configured as H1-□□ = 15 (N.O. input) or 17 (N.C. input). A momentary closure of the digital input will trigger the Fast Stop operation; it does not have to be closed continuously.

The drive cannot be restarted after initiating a Fast Stop operation until after completing deceleration, clearing the Fast Stop input, and cycling the Run command.

A digital output programmed for “During Fast Stop” (H2-□□ = 4C) will be closed as long as Fast Stop is active.

No.	Parameter Name	Setting Range	Default
C1-09	Fast Stop Time	0.0 to 6000.0 s <1>	10.0 s

<1> The setting range for the acceleration and deceleration times is determined by the accel/decel time setting units in C1-10. For example, if the time is set in units of 0.01 s (C1-10 = 0), the setting range becomes 0.00 to 600.00 s

## 1.3 C: Tuning

**NOTICE:** Rapid deceleration can trigger an overvoltage fault. The drive output shuts off when faulted and the motor coasts. Set an appropriate Fast Stop time to C1-09 to avoid this uncontrolled motor state and to ensure that the motor stops quickly and safely.

### ■ C1-10: Accel/Decel Time Setting Units

Determines the units for the acceleration and deceleration times set to C1-01 through C1-09 using parameter C1-10.

No.	Parameter Name	Setting Range	Default
C1-10	Accel/Decel Time Setting Units	0, 1	1

#### Setting 0: 0.01 s units

The accel/decel times are set in 0.01 s units. The setting range will be 0.00 to 600.00 s. C1-10 cannot be set to 0 if any of the parameters C1-01 to C1-09 are set to 600.1 seconds or more.

#### Setting 1: 0.1 s units

The accel/decel times are set in 0.1 s units. The setting range will be 0.0 to 6000.0 s.

## ◆ C2: S-Curve Characteristics

Use S-curve characteristics to smooth acceleration and deceleration and minimize abrupt shock to the load. Set S-curve characteristic time during acceleration/deceleration at start and acceleration/deceleration at stop. Increase the value set to C2-01 if the STo fault (Hunting Detection) occurs when starting a PM motor.

### ■ C2-01 to C2-04: S-Curve Characteristics

C2-01 through C2-04 set separate S-curves for each section of the acceleration or deceleration.

No.	Parameter Name	Setting Range	Default
C2-01	S-Curve Characteristic at Accel Start	0.00 to 10.00 s	Determined by A1-02
C2-02	S-Curve Characteristic at Accel End		0.20 s
C2-03	S-Curve Characteristic at Decel Start		0.20 s
C2-04	S-Curve Characteristic at Decel End		0.00 s

Figure 1.31 illustrates S-curve application.

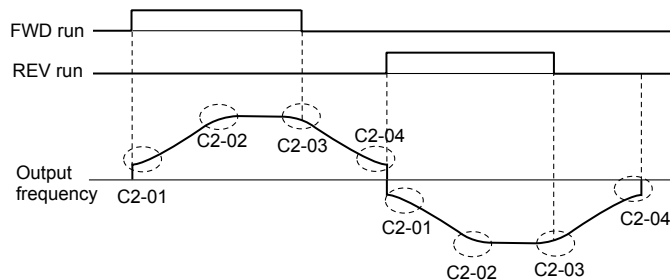

Figure 1.31 S-Curve Timing Diagram - FWD/REV Operation

Setting the S-curve will increase the acceleration and deceleration times.

- Actual accel time = accel time setting + (C2-01 + C2-02) / 2
- Actual decel time = decel time setting + (C2-03 + C2-04) / 2

## ◆ C3: Slip Compensation

The Slip Compensation function improves the speed accuracy of an induction motor. By adjusting the output frequency in accordance with the motor load, it compensates the slip and makes the motor speed equal to the frequency reference.

**Note:** Perform Auto-Tuning and make sure that the motor rated current (E2-01), the motor rated slip (E2-02), and the no-load current (E2-03) have all been set properly before making any adjustments to slip compensation parameters.

### ■ C3-01: Slip Compensation Gain

Sets the gain for the motor slip compensation function. Although this parameter rarely needs to be changed, adjustments may be necessary under the following circumstances:

- Increase the setting if the motor at constant speed is slower than the frequency reference.



- Decrease the setting if the motor at constant speed is faster than the frequency reference.

No.	Parameter Name	Setting Range	Default
C3-01	Slip Compensation Gain	0.0 to 2.5	Determined by A1-02

**Note:** Default setting is 0.0 in V/f Control (A1-02 = 0), and 1.0 in Open Loop Vector Control (A1-02 = 2). In Closed Loop Vector Control, slip compensation corrects inaccuracies that can result from temperature fluctuation in the rotor.

### ■ C3-02: Slip Compensation Primary Delay Time

Adjusts the filter on the output side of the slip compensation function. Although this parameter rarely needs to be changed, adjustments may be necessary in the following situations:

- Decrease the setting when the slip compensation response is too slow.
- Increase this setting when speed is unstable.

No.	Parameter Name	Setting Range	Default
C3-02	Slip Compensation Primary Delay Time	0 to 10000 ms	Determined by A1-02

**Note:** Default for V/f Control (A1-02 = 0) is 2000 ms. Default for Open Loop Vector Control (A1-02 = 2) is 200 ms.

### ■ C3-03: Slip Compensation Limit

Sets the upper limit for the slip compensation function as a percentage of the motor rated slip (E2-02).

No.	Parameter Name	Setting Range	Default
C3-03	Slip Compensation Limit	0 to 250%	200%

The slip compensation limit is constant throughout the constant torque range (frequency reference  $\leq$  E1-06). In the constant power range (frequency reference  $\geq$  E1-06), it is increased based on C3-03 and the output frequency as shown in the following diagram.

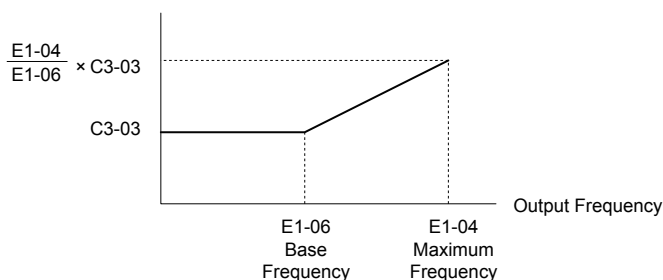

Figure 1.32 Slip Compensation Limit

### ■ C3-04: Slip Compensation Selection during Regeneration

Enables or disables slip compensation during regenerative operation. When slip compensation during regeneration has been activated and a regenerative load is applied, it might be necessary to use a dynamic braking option (braking resistor, braking resistor unit, or braking unit).

This function does not operate when the output frequency is too low, regardless of whether it has been enabled.

No.	Parameter Name	Setting Range	Default
C3-04	Slip Compensation Selection during Regeneration	0 to 2	0

#### Setting 0: Disabled

Slip compensation is not provided. Depending on the load and mode of operation, the actual motor speed will be lower or higher than the frequency reference.

#### Setting 1: Enabled (6 Hz and above)

Slip compensation is enabled during regenerative operation. It will not be active at output frequencies below 6 Hz.

#### Setting 2: Enabled (compensation provided wherever possible)

Slip compensation is enabled during regenerative operation and at frequencies as low as 2 Hz. The drive uses the motor rated slip set to E2-02 to automatically calculate the frequency range where compensation will be disabled.

## 1.3 C: Tuning

### ■ C3-05: Output Voltage Limit Operation Selection

Determines if the motor flux reference is automatically reduced when output voltage reaches the saturation range.

If the input power supply voltage is low or the motor has a high voltage rating, this function improves the speed precision when moving heavy loads at high speeds. When selecting the drive, remember that the reduction in flux causes a slightly higher current at high speed when this function is enabled.

No.	Parameter Name	Setting Range	Default
C3-05	Output Voltage Limit Operation Selection	0, 1	0

**Note:** Available control modes for parameter C3-05 vary by drive model:  
CIMR-A□2A0004 to 2A0415, 4A0002 to 4A0675, and 5A0003 to 5A0242: Available when A1-02 = 0, 1  
CIMR-A□4A0930 and 4A1200: Available when A1-02 = 2, 3, 6, 7  
A1000 HHP: Available when A1-02 = 2 or 3

**Setting 0: Disabled**

**Setting 1: Enabled**

### ■ C3-16: Output Voltage Limit Operation Start Level (Percentage Modulation)

Sets the output voltage limit operation start level (percentage modulation) when C3-05 is enabled.

**Note:** This parameter is only available in models CIMR-A□4A0930, 4A1200 and A1000 HHP.

No.	Parameter Name	Setting Range	Default
C3-16	Output Voltage Limit Operation Start Level	70.0 to 90.0%	85.0%

### ■ C3-17: Maximum Output Voltage Limit Level (Percentage Modulation)

Sets the output voltage limit operation determined by C3-18 (percentage modulation) when C3-05 is enabled.

**Note:** This parameter is only available in models CIMR-A□4A0930, 4A1200 and A1000 HHP.

No.	Parameter Name	Setting Range	Default
C3-17	Maximum Output Voltage Limit Level	85.0 to 100.0%	90.0%

### ■ C3-18: Output Voltage Limit Level

Sets the maximum percentage of output voltage reduction when C3-05 is enabled.

**Note:** This parameter is only available in models CIMR-A□4A0930, 4A1200 and A1000 HHP.

No.	Parameter Name	Setting Range	Default
C3-18	Output Voltage Limit Level	30.0 to 100.0%	90.0%

### ■ C3-21: Motor 2 Slip Compensation Gain

Improves the speed accuracy for motor 2 and functions in the same way that C3-01 functions for motor 1. Adjust this parameter only after setting the motor rated current (E4-01), motor rated slip (E4-02), and the motor no-load current (E4-03).

*Refer to C3-01: Slip Compensation Gain on page 48* for details on adjusting this parameter.

No.	Parameter Name	Setting Range	Default
C3-21	Motor 2 Slip Compensation Gain	0.0 to 2.5	Determined by E3-01

**Note:** Default setting is 0.0 in V/f Control (A1-02 = 0). Default setting is 1.0 in Open Loop Vector Control (A1-02 = 2) and Closed Loop Vector Control (A1-02 = 3). In Closed Loop Vector Control, slip compensation gain acts as an adaptable gain.

### ■ C3-22: Motor 2 Slip Compensation Primary Delay Time

Functions for motor 2 the same way that C3-02 functions for motor 1.

*Refer to C3-02: Slip Compensation Primary Delay Time on page 49* for details on adjusting this parameter.

No.	Parameter Name	Setting Range	Default
C3-22	Motor 2 Slip Compensation Primary Delay Time	0 to 10000 ms	Determined by A1-02

**Note:** The default for V/f Control (A1-02 = 0) is 2000 ms. The default for Open Loop Vector Control (A1-02 = 2) is 200 ms.

### ■ C3-23: Motor 2 Slip Compensation Limit

Sets the upper limit for the slip compensation function as a percentage of the motor rated slip (E4-02).

No.	Parameter Name	Setting Range	Default
C3-23	Motor 2 Slip Compensation Limit	0 to 250%	200%

The slip compensation limit is constant throughout the constant torque range (frequency reference  $\leq$  E3-06). In the constant power range (frequency reference  $\geq$  E3-06), it is increased based on C3-23 and the output frequency as illustrated in the following diagram.

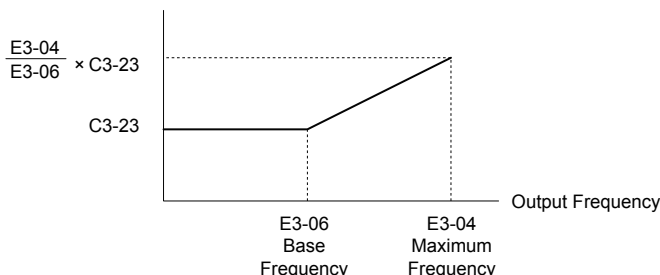

Figure 1.33 Slip Compensation Limit

### ■ C3-24: Motor 2 Slip Compensation Selection during Regeneration

Functions for motor 2 the same way that C3-04 functions for motor 1.

*Refer to C3-04: Slip Compensation Selection during Regeneration on page 49* for details on adjusting this parameter.

No.	Parameter Name	Setting Range	Default
C3-24	Motor 2 Slip Compensation Selection during Regeneration	0 to 2	0

**Setting 0: Disabled**

**Setting 1: Enabled (6 Hz and above)**

**Setting 2: Enabled (compensation provided wherever possible)**

## ◆ C4: Torque Compensation

The torque compensation function compensates for insufficient torque production at start-up or when a load is applied.

**Note:** Set the motor parameters and V/f pattern properly before setting torque compensation parameters.

### ■ C4-01: Torque Compensation Gain

Sets the gain for the torque compensation function.

No.	Parameter Name	Setting Range	Default
C4-01	Torque Compensation Gain	0.00 to 2.50	Determined by A1-02

#### Torque Compensation in V/f, V/f w/PG, and OLV/PM:

**Note:** PM motor control modes are not available in A1000 HHP drive models.

The drive calculates the motor primary voltage loss using the output current and the termination resistor value (E2-05 for IM motors, E5-05 for PM motors) and adjusts the output voltage to compensate insufficient torque at start or when load is applied. The effects of this voltage compensation can be increased or decreased using parameter C4-01.

#### Torque Compensation in OLV:

The drive controls the motor excitation current (d-Axis current) and torque producing current (q-Axis current) separately. Torque compensation affects the torque producing current only. C4-01 works as a factor of the torque reference value that builds the torque producing current reference.

## 1.3 C: Tuning

### Adjustment

Although this parameter rarely needs to be changed, it may be necessary to adjust the torque compensation gain in small steps of 0.05 in the following situations:

- Increase this setting when using a long motor cable.
- Decrease this setting when motor oscillation occurs.

Adjust C4-01 so the output current does not exceed the drive rated current.

- Note:**
1. Refrain from adjusting torque compensation in Open Loop Vector Control, as it can have a negative effect on torque accuracy.
  2. Refrain from adjusting this parameter in OLV/PM. Setting this value too high can cause overcompensation and motor oscillation.

### ■ C4-02: Torque Compensation Primary Delay Time

Sets the delay time used for applying torque compensation.

No.	Parameter Name	Setting Range	Default
C4-02	Torque Compensation Primary Delay Time	0 to 60000 ms	Determined by A1-02

### Adjustment

Although C4-02 rarely needs to be changed, adjustments may be necessary in the following situations:

- Increase this setting if the motor vibrates.
- Decrease this setting if the motor responds too slowly to changes in the load.

### ■ C4-03: Torque Compensation at Forward Start (OLV)

Sets the amount of torque at start in the forward direction to improve motor performance during start with a heavy load. Compensation is applied using the time constant set in parameter C4-05. Enable this function when the load pulls the motor in reverse when starting with a Forward run command. Setting 0.0% disables this feature.

No.	Parameter Name	Setting Range	Default
C4-03	Torque Compensation at Forward Start	0.0 to 200.0%	0.0%

### ■ C4-04: Torque Compensation at Reverse Start (OLV)

Sets the amount of torque reference at start in the reverse direction to improve motor performance during start with heavy load. Compensation is applied using the time constant set in parameter C4-05. Enable this function if the load pulls the motor in the forward direction when starting with a Reverse run command. Setting 0.0% disables this feature.

No.	Parameter Name	Setting Range	Default
C4-04	Torque Compensation at Reverse Start	-200.0 to 0.0%	0.0%

### ■ C4-05: Torque Compensation Time Constant (OLV)

Sets the time constant for applying the torque compensation at start that is set to C4-03 and C4-04.

No.	Parameter Name	Setting Range	Default
C4-05	Torque Compensation Time Constant	0 to 200 ms	10 ms

### ■ C4-06: Torque Compensation Primary Delay Time 2 (OLV)

Sets the time constant used during Speed Search or during regenerative operation. Adjust the value if an overvoltage fault occurs with sudden changes in the load or at the end of acceleration with high inertia load.

No.	Parameter Name	Setting Range	Default
C4-06	Torque Compensation Primary Delay Time 2	0 to 10000 ms	150 ms

- Note:** If C4-06 is set to a relatively large value, increase the setting in n2-03 (AFR Time Constant 2) proportionally.

### ■ C4-07: Motor 2 Torque Compensation Gain

Functions for motor 2 the same way that C4-01 functions for motor 1.

*Refer to C3-01: Slip Compensation Gain on page 48* for details on adjusting this parameter.

No.	Parameter Name	Setting Range	Default
C4-07	Motor 2 Torque Compensation Gain	0.00 to 2.50	1.00

## ◆ C5: Automatic Speed Regulator (ASR)

The ASR controls the motor speed in V/f w/PG, CLV, AOLV/PM, and CLV/PM control modes and adjusts the output frequency (V/f w/PG) or torque reference (CLV, AOLV/PM, CLV/PM) to minimize the difference between frequency reference and actual motor speed.

The figures below illustrate ASR functionality:

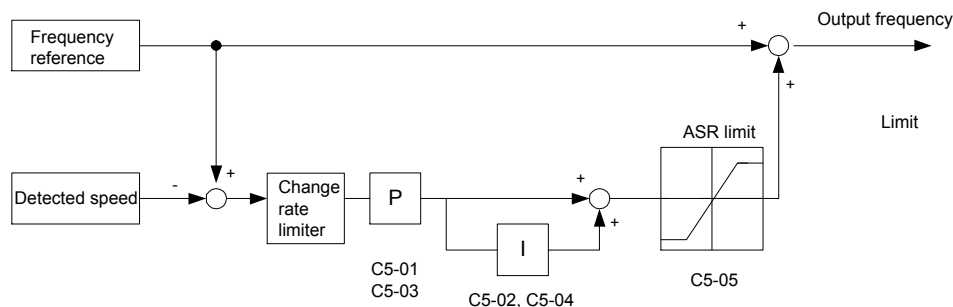

Figure 1.34 Speed Control Block Diagram for V/f Control with PG

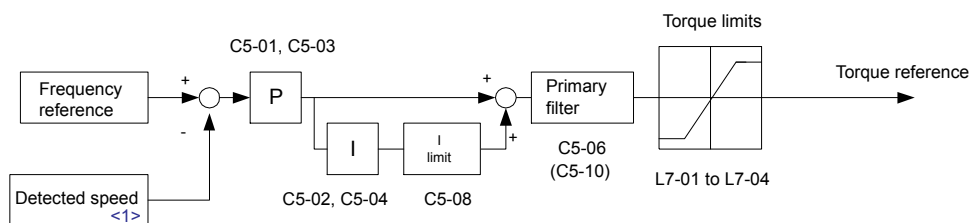

Figure 1.35 Speed Control Block Diagram for CLV, AOLV/PM and CLV/PM

<1> AOLV/PM estimates the speed using the motor model and does not require an encoder feedback signal.

**Note:** PM motor control modes are not available in A1000 HHP drive models.

### ■ Adjusting the ASR Parameters

Perform Auto-Tuning and set up all motor data correctly prior to adjusting ASR parameters.

Use analog output signals to monitor the frequency reference after softstarter (U1-16) and the motor speed (U1-05) when adjusting the ASR. [Refer to H4: Multi-Function Analog Outputs on page 120](#) for details on setting up analog output functions.

Generally when tuning the ASR, optimize the ASR gain before adjusting the integral time settings. Always make adjustments with the load connected to the motor.

#### Adjusting the ASR Parameters in V/f Control with PG

In V/f Control with PG, the ASR settings change between two sets of parameters depending on the motor speed as described in [C5-01, C5-03/C5-02, C5-04: ASR Proportional Gain 1, 2/ASR Integral Time 1, 2](#) on page 54.

Perform the following steps for adjusting ASR parameters:

1. Run the motor at minimum speed and increase ASR gain 2 (C5-03) as much as possible without oscillation.
2. Run the motor at minimum speed and decrease ASR integral time 2 (C5-04) as much as possible without oscillation.
3. Check the output current monitor to make sure that the output current is less than 50% of the drive rated current. If the value is higher than 50%, decrease C5-03 and increase C5-04.
4. Run the motor at maximum speed and increase ASR gain 1 (C5-01) as much as possible without oscillations.
5. Run the motor at maximum speed and decrease ASR integral time 1 (C5-02) as much as possible without oscillations.
6. If higher speed precision and faster response during acceleration or deceleration are required, enable integral control during accel/decel by setting parameter C5-12 to 1. Change the speed and make sure no over/undershoot occurs.

#### Adjusting the ASR Parameters in CLV, AOLV/PM, and CLV/PM

**Note:** PM motor control modes are not available in A1000 HHP drive models.

### 1.3 C: Tuning

The drive is preset to use ASR settings C5-01/02 over the entire speed range in CLV, AOLV/PM, and CLV/PM. If required by the application, a second set of ASR parameters (C5-03/04) can be automatically activated depending on the motor speed or by using a digital input. *Refer to C5-01, C5-03/C5-02, C5-04: ASR Proportional Gain 1, 2/ASR Integral Time 1, 2 on page 54.*

Perform the following steps for adjusting ASR parameters:

1. Run the motor at zero speed and increase the ASR gain (C5-01) as much as possible without oscillation.
2. Run the motor at zero speed and decrease the ASR integral time (C5-02) as much as possible without oscillation.
3. Run at the normal operating speed. Check for over/undershoot when changing speed and for any oscillation.
4. If problems occur in step 3, increase the integral time and reduce the gain.  
Alternatively, use different ASR settings for high and low speed. Set the values from step 1 and 2 to parameters C5-03 and C5-04, then set an ASR switching frequency in parameter C5-07. Run the motor at a speed higher than C5-07 and repeat step 3 while adjusting C5-01 and C5-02.

#### Solving Problems During ASR Setup

Use [Table 1.24](#) when making adjustments to ASR. Though the parameters listed below are for motor 1, the same changes can be made to the corresponding motor 2 parameters when running a second motor.

**Table 1.24 ASR Setup Problems and Corrective Actions**

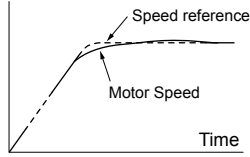
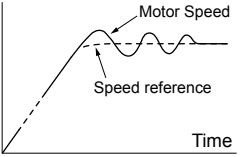
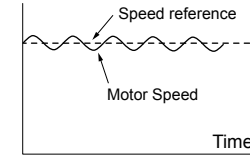
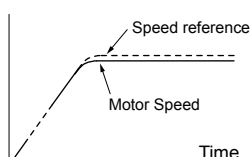
Problem		Possible Solutions
Slow response to speed changes or speed deviation lasts for too long		<ul style="list-style-type: none"> <li>• Increase the ASR gain.</li> <li>• Decrease the integral time.</li> </ul>
Overshoot or undershoot at the end of acceleration or deceleration		<ul style="list-style-type: none"> <li>• Decrease the ASR gain.</li> <li>• Increase the integral time.</li> </ul>
Vibration and oscillation occur at constant speed		<ul style="list-style-type: none"> <li>• Decrease the ASR gain.</li> <li>• Increase the integral time.</li> <li>• Increase the ASR delay time (C5-06).</li> </ul>
The motor slip is not fully compensated when running in V/f Control with PG		<ul style="list-style-type: none"> <li>• Check the pulse number set to F1-01 and the gear ratio in F1-12 and F1-13.</li> <li>• Make sure the pulse signal from the encoder is set up properly.</li> <li>• Check monitor U6-04 and determine if the ASR is working at its output limit (setting of C5-05). If the ASR is at the output limit, increase C5-05.</li> </ul>
Integral operation is enabled in V/f Control with PG (C5-12 = 1) and over/undershoot occurs when changing speed.	-	<ul style="list-style-type: none"> <li>• Decrease the ASR gain.</li> <li>• Increase the integral time.</li> <li>• Reduce the ASR output limit set in C5-05.</li> </ul>
Oscillation at low speed and response is too slow at high speed (or vice versa)	-	<ul style="list-style-type: none"> <li>• V/f control: Use C5-01/02 and C5-03/04 to set up different ASR settings at minimum and maximum speed.</li> <li>• CLV, AOLV/PM, CLV/PM: Use C5-01, C5-02 and C5-03, C5-04 to define optimal ASR settings for high and low speed. Use C5-07 to define a switching frequency.</li> </ul>

#### ■ C5-01, C5-03/C5-02, C5-04: ASR Proportional Gain 1, 2/ASR Integral Time 1, 2

These parameters adjust the responsiveness of the ASR.

**Note:** C5-01 is automatically set when ASR Tuning is performed (T1-01 = 9 or T2-01 = 9).

No.	Parameter Name	Setting Range	Default
C5-01	ASR Proportional Gain 1	0.00 to 300.00	Determined by A1-02
C5-02	ASR Integral Time 1	0.000 to 10.000 s	Determined by A1-02
C5-03	ASR Proportional Gain 2	0.00 to 300.00	Determined by A1-02
C5-04	ASR Integral Time 2	0.000 to 10.000 s	Determined by A1-02

These parameter settings will function differently depending on the control mode.

**V/f Control with PG**

Parameters C5-01 and C5-02 determine the ASR characteristics at maximum speed. Parameters C5-03 and C5-04 determine the characteristics at minimum speed.

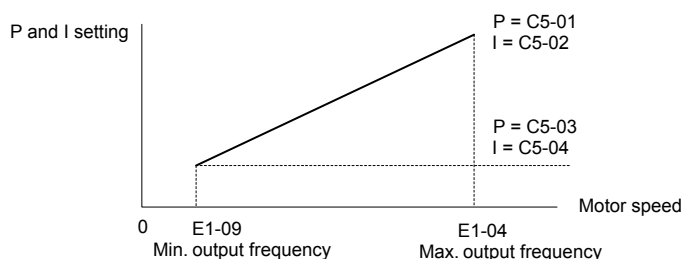

Figure 1.36 ASR Gain and Integral Time in V/f w/PG

**CLV, AOLV/PM, and CLV/PM**

**Note:** PM motor control modes are not available in A1000 HHP drive models.

In these control modes, parameters C5-03 and C5-04 define the ASR gain and integral time at zero speed. The settings in C5-01 and C5-02 are used at speeds above the setting in C5-07. C5-07 is set to 0 as the default so that C5-01 and C5-02 are used over the entire speed range. Refer to C5-07: ASR Gain Switching Frequency on page 56.

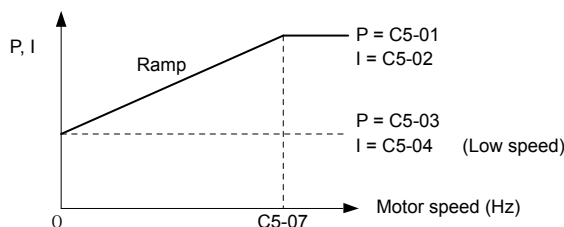

Figure 1.37 Low-speed and High-speed Gain Settings

The gain set in C5-03 can also be activated with a digital input programmed to “ASR gain switch” (H1-□□ = 77). When the terminal is open, the drive uses the ASR gain level set by the pattern in the figure above. When the terminal closes, C5-03 is used. The integral time set to C5-02 is used to change linearly between these settings. The ASR gain switch command from a multi-function input terminal overrides the switching frequency set to C5-07.

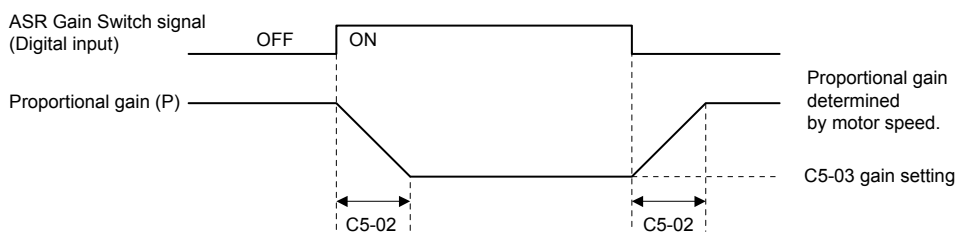

Figure 1.38 ASR Proportional Gain Switch

**ASR Gain Tuning (C5-01, C5-03)**

The higher this setting, the faster the speed response, although a setting that is too high can lead to oscillation. Increase this setting with larger loads to minimize the speed deviation.

## 1.3 C: Tuning

### ASR Integral Time Tuning (C5-02, C5-04)

Determines how fast a continuous speed deviation problem is eliminated. A setting that is too long reduces the responsiveness of the speed control. A setting that is too short can cause oscillation.

#### ■ C5-05: ASR Limit

Sets the ASR output limit as a percentage of the maximum output frequency (E1-04). If the motor rated slip is high, the setting might need to be increased to provide proper motor speed control. Use the ASR output monitor U6-04 to determine if ASR is working at the limit set in C5-05. If ASR is working at the limit, make sure the PG pulses (F1-01), PG gear teeth (F1-12, F1-13), and the PG signal are set correctly before making further changes to C5-05.

No.	Parameter Name	Setting Range	Default
C5-05	ASR Limit	0.0 to 20.0%	5.0%

#### ■ C5-06: ASR Primary Delay Time Constant

Sets the filter time constant for the time from the speed loop to the torque command output. Increase this setting gradually in increments of 0.01 for loads with low rigidity or when oscillation is a problem. This parameter rarely needs to be changed.

No.	Parameter Name	Setting Range	Default
C5-06	ASR Primary Delay Time Constant	0.000 to 0.500 s	Determined by A1-02

#### ■ C5-07: ASR Gain Switching Frequency

Sets the frequency where the drive should switch between ASR proportional gain 1 and 2 (C5-01, C5-03) as well as between integral time 1 and 2 (C5-02, C5-04).

No.	Parameter Name	Setting Range	Default
C5-07	ASR Gain Switching Frequency	0.0 to 400.0 Hz	0.0 Hz

**Note:** A multi-function input set for the ASR gain switch (H1-□□ = 77) takes priority over the ASR gain switching frequency.

Switching the proportional gain and integral time in the low or high speed range can help stabilize operation and avoid resonance problems. A good switching point is 80% of the frequency where oscillation occurs or at 80% of the target speed. [Refer to C5-01, C5-03/C5-02, C5-04: ASR Proportional Gain 1, 2/ASR Integral Time 1, 2 on page 54.](#)

#### ■ C5-08: ASR Integral Limit

Sets the upper limit for ASR as a percentage of the rated load.

No.	Parameter Name	Setting Range	Default
C5-08	ASR Integral Limit	0 to 400%	400%

#### ■ C5-12: Integral Operation during Accel/Decel (V/f w/PG)

Enables integral operation during acceleration and deceleration. Use integral operation when driving a heavy load or a high inertia load (default). Set C5-12 to 1 to use integral operation for low inertia/high performance loads. Enabling integral operation may cause problems with overshoot at the end of acceleration and deceleration. [Refer to ASR Setup Problems and Corrective Actions on page 54](#) to solve such problems.

No.	Parameter Name	Setting Range	Default
C5-12	Integral Operation during Accel/Decel	0, 1	0

##### Setting 0: Disabled

Integral operation occurs only during constant speed and not during acceleration or deceleration.

##### Setting 1: Enabled

Integral operation is always enabled.

#### ■ C5-21, C5-23 / C5-22, C5-24: Motor 2 ASR Proportional Gain 1, 2 / Integral Time 1, 2

These parameters function for motor 2 the same way that C5-01 through C5-04 function for motor 1. [Refer to C5-01, C5-03/C5-02, C5-04: ASR Proportional Gain 1, 2/ASR Integral Time 1, 2 on page 54](#) for details.



No.	Parameter Name	Setting Range	Default
C5-21	Motor 2 ASR Proportional Gain 1	0.00 to 300.00	Determined by E3-01
C5-22	Motor 2 ASR Integral Time 1	0.000 to 10.000 s	Determined by E3-01
C5-23	Motor 2 ASR Proportional Gain 2	0.00 to 300.00	Determined by E3-01
C5-24	Motor 2 ASR Integral Time 2	0.000 to 10.000 s	Determined by E3-01

### ■ C5-25: Motor 2 ASR Limit

Functions for motor 2 the same way that C5-05 functions for motor 1. Sets the ASR output limit for motor 2 as a percentage of the maximum output frequency (E4-04). *Refer to C5-05: ASR Limit on page 56* for details.

No.	Parameter Name	Setting Range	Default
C5-25	Motor 2 ASR Limit	0.0 to 20.0%	5.0%

### ■ C5-26: Motor 2 ASR Primary Delay Time Constant

Functions for motor 2 the same way that C5-06 functions for motor 1. Sets the filter time constant for the time from the speed loop to the torque command output. *Refer to C5-06: ASR Primary Delay Time Constant on page 56* for details. This parameter rarely needs to be changed.

No.	Parameter Name	Setting Range	Default
C5-26	Motor 2 ASR Primary Delay Time Constant	0.000 to 0.500 s	0.004 s

### ■ C5-27: Motor 2 ASR Gain Switching Frequency

Functions for motor 2 the same way that C5-07 functions for motor 1. Sets the frequency for motor 2 to change ASR proportional gain 1 and 2 (C5-21, C5-23) as well as the integral time 1 and 2 (C5-22, C5-24). *Refer to C5-01, C5-03/C5-02, C5-04: ASR Proportional Gain 1, 2/ASR Integral Time 1, 2 on page 54* for details.

No.	Parameter Name	Setting Range	Default
C5-27	Motor 2 ASR Gain Switching Frequency	0.0 to 400.0 Hz	0.0 Hz

**Note:** A multi-function input set for the ASR gain switch (H1-□□ = 77) takes priority over the ASR gain switching frequency.

### ■ C5-28: Motor 2 ASR Integral Limit

Functions for motor 2 the same way that C5-08 functions for motor 1. Sets the upper limit for ASR as a percentage of the rated load. *Refer to C5-08: ASR Integral Limit on page 56* for details.

No.	Parameter Name	Setting Range	Default
C5-28	Motor 2 ASR Integral Limit	0 to 400%	400%

### ■ C5-32: Integral Operation during Accel/Decel for Motor 2

Functions for motor 2 the same way that C5-12 functions for motor 1. Enables integral operation during acceleration and deceleration. *Refer to C5-12: Integral Operation during Accel/Decel (V/f w/PG) on page 56* for details.

No.	Parameter Name	Setting Range	Default
C5-32	Integral Operation during Accel/Decel for Motor 2	0, 1	0

#### Setting 0: Disabled

Integral operation occurs only during constant speed and not during acceleration or deceleration.

#### Setting 1: Enabled

Integral operation is always enabled.

## ◆ C6: Carrier Frequency

### ■ C6-01: Drive Duty Mode Selection

The drive has two different duty modes from which to select based on the load characteristics. The drive rated current, overload capacity, and maximum output frequency will change depending upon the duty mode selection. Use parameter C6-01 to select Heavy Duty (HD) or Normal Duty (ND) for the application.

### 1.3 C: Tuning

No.	Parameter Name	Setting Range	Default
C6-01	Duty Mode Selection	0, 1	1 (ND)

**Table 1.25 Differences between Heavy Duty and Normal Duty**

Characteristics	Heavy Duty Rating (HD)	Normal Duty Rating (ND)
<b>C6-01</b>	0	1
<b>Performance</b>		
<b>Application</b>	Use Heavy Duty Rating for applications requiring a high overload tolerance with constant load torque, such as extruders and conveyors.	Use Normal Duty Rating for applications in which the torque requirements drop along with the speed, such as fans and pumps where a high overload tolerance is not required.
<b>Overload capability (oL2)</b>	150% of drive rated Heavy Duty current for 60 s	120% of drive rated Normal Duty current for 60 s
<b>Stall Prevention during Acceleration (L3-02)</b>	150%	120%
<b>Stall Prevention during Run (L3-06)</b>	150%	120%
<b>Default Carrier Frequency</b>	2 kHz	2 kHz Swing PWM

**Note:** Changing the Duty Mode selection automatically changes the maximum size motor that the drive can run, sets the E2-□□ parameters to appropriate values (E4-□□ for motor 2), and recalculates parameter settings determined by motor capacity (e.g., b8-04, L2-03, n5-02, L3-24, C5-17, and C5-37).

#### ■ C6-02: Carrier Frequency Selection

Sets the switching frequency of the drive output transistors. Changes to the switching frequency lower audible noise and reduce leakage current.

No.	Parameter Name	Setting Range	Default
C6-02	Carrier Frequency Selection	1	1

#### Settings:

C6-02	Carrier Frequency	C6-02	Carrier Frequency	C6-02	Carrier Frequency
1	2.0 kHz	5	12.5 kHz (10.0 kHz)	9	Swing PWM 3

#### ■ C6-05: Carrier Frequency Proportional Gain

This parameter sets a user-defined or a variable carrier frequency. Set C6-02 to F to set the carrier frequency proportional gain.

No.	Parameter Name	Setting Range	Default
C6-05	Carrier Frequency Proportional Gain (V/f Control only)	0 to 99	Determined by C6-02

## 1.4 d: Reference Settings

The figure below gives an overview of the reference input, selections, and priorities.

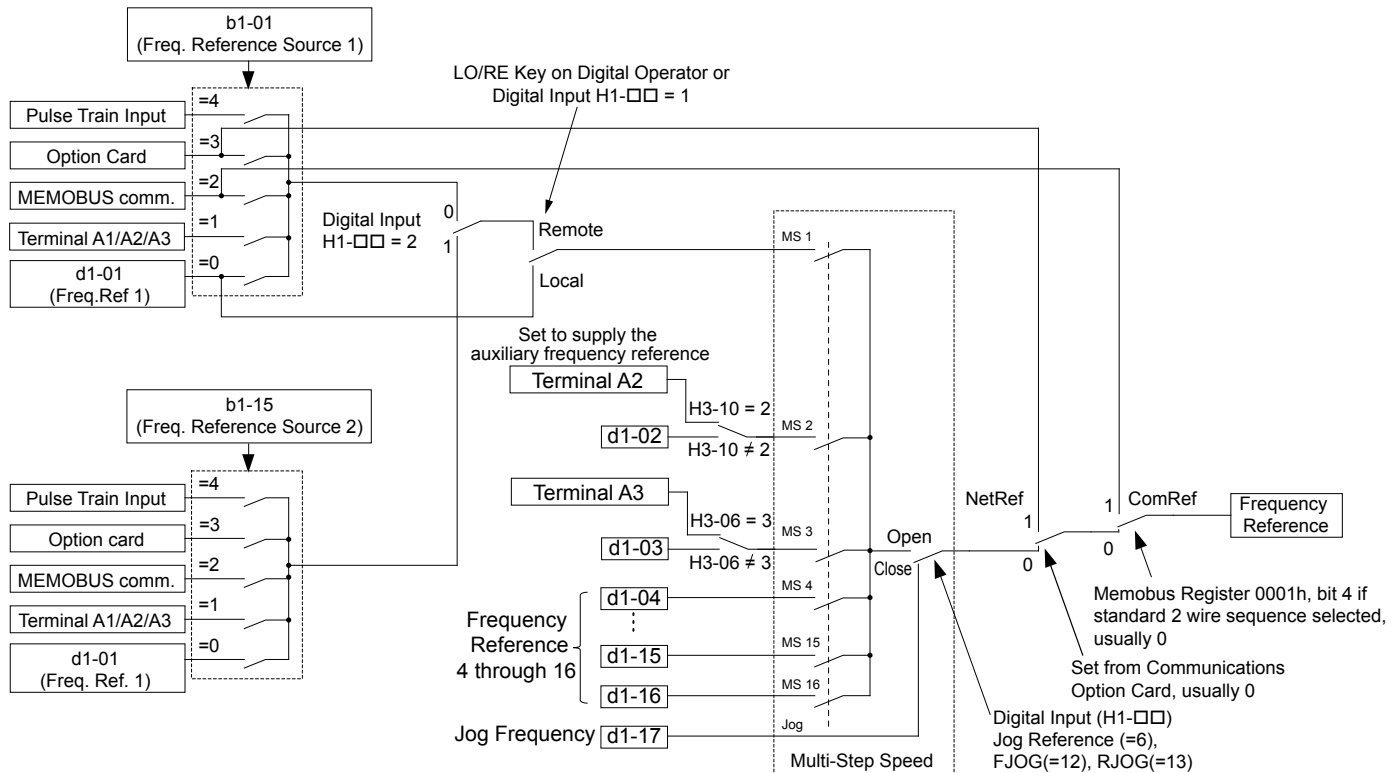

Figure 1.39 Frequency Reference Setting Hierarchy

### ◆ d1: Frequency Reference

#### ■ d1-01 to d1-17: Frequency Reference 1 to 16 and Jog Frequency Reference

The drive lets the user switch between up to 17 preset frequency references during run (including the Jog reference) through the digital input terminals. The drive uses the acceleration and deceleration times that have been selected when switching between each frequency reference.

The Jog frequency overrides all other frequency references and must be selected by a separate digital input.

The multi-speed references 1, 2, and 3 can be provided by analog inputs.

No.	Parameter Name	Setting Range	Default
d1-01 to d1-16	Frequency Reference 1 to 16	0.00 to 150.00 Hz <f> <f>	0.00 Hz <f>
d1-17	Jog Frequency Reference	0.00 to 150.00 Hz <f> <f>	6.00 Hz <f>

<1> The upper limit is determined by the maximum output frequency (E1-04) and upper limit for the frequency reference (d2-01).

<2> Setting units are determined by parameter o1-03. The default is “Hz” (o1-03 = 0) in V/f, V/f w/PG, OLV, CLV, and OLV/PM control modes. The default for AOLV/PM and CLV/PM control modes expresses the frequency reference as a percentage (o1-03 = 1).

#### Multi-Step Speed Selection

To use several speed references for a multi-step speed sequence, set the H1-□□ parameters to 3, 4, 5, and 32. To assign the Jog reference to a digital input, set H1-□□ to 6.

Notes on using analog inputs as Multi-Speed 1, 2, and 3:

- The first frequency reference (Multi-Speed 1) comes from the source specified in b1-01. When using an analog input terminal to supply the frequency reference, assign the frequency reference source to the control terminals (b1-01 = 1).
- When an analog input is set to “Auxiliary frequency 1” (H3-02, H2-06, or H2-10 = 2), the value set to this input will be used as the Multi-Speed Speed 2 instead of the value set to parameter d1-02. If no analog inputs are set for “Auxiliary frequency 1”, then d1-02 becomes the reference for Multi-Speed Speed 2.

## 1.4 d: Reference Settings

- When an analog input is set to “Auxiliary frequency 2” (H3-02, H2-06, or H2-10 = 3), the value set to this input will be used as the Multi-Step Speed 3 instead of the value set to parameter d1-03. If no analog inputs are set for “Auxiliary frequency 2”, then d1-03 becomes the reference for Multi-Step Speed 3.

Select the different speed references as shown in *Table 1.26*. *Figure 1.40* illustrates the multi-step speed selection.

**Table 1.26 Multi-Step Speed Reference and Terminal Switch Combinations**

Reference	Multi-Step Speed H1-□□ = 3	Multi-Step Speed 2 H1-□□ = 4	Multi-Step Speed 3 H1-□□ = 5	Multi-Step Speed 4 H1-□□ = 32	Jog Reference H1-□□ = 6
Frequency Reference 1 (set in b1-01)	OFF	OFF	OFF	OFF	OFF
Frequency Reference 2 (d1-02 or input terminal A1, A2, A3)	ON	OFF	OFF	OFF	OFF
Frequency Reference 3 (d1-03 or input terminal A1, A2, A3)	OFF	ON	OFF	OFF	OFF
Frequency Reference 4 (d1-04)	ON	ON	OFF	OFF	OFF
Frequency Reference 5 (d1-05)	OFF	OFF	ON	OFF	OFF
Frequency Reference 6 (d1-06)	ON	OFF	ON	OFF	OFF
Frequency Reference 7 (d1-07)	OFF	ON	ON	OFF	OFF
Frequency Reference 8 (d1-08)	ON	ON	ON	OFF	OFF
Frequency Reference 9 (d1-09)	OFF	OFF	OFF	ON	OFF
Frequency Reference 10 (d1-10)	ON	OFF	OFF	ON	OFF
Frequency Reference 11 (d1-11)	OFF	ON	OFF	ON	OFF
Frequency Reference 12 (d1-12)	ON	ON	OFF	ON	OFF
Frequency Reference 13 (d1-13)	OFF	OFF	ON	ON	OFF
Frequency Reference 14 (d1-14)	ON	OFF	ON	ON	OFF
Frequency Reference 15 (d1-15)	OFF	ON	ON	ON	OFF
Frequency Reference 16 (d1-16)	ON	ON	ON	ON	OFF
Jog Frequency Reference (d1-17) <1>	–	–	–	–	ON

<1> The Jog frequency overrides all other frequency references.

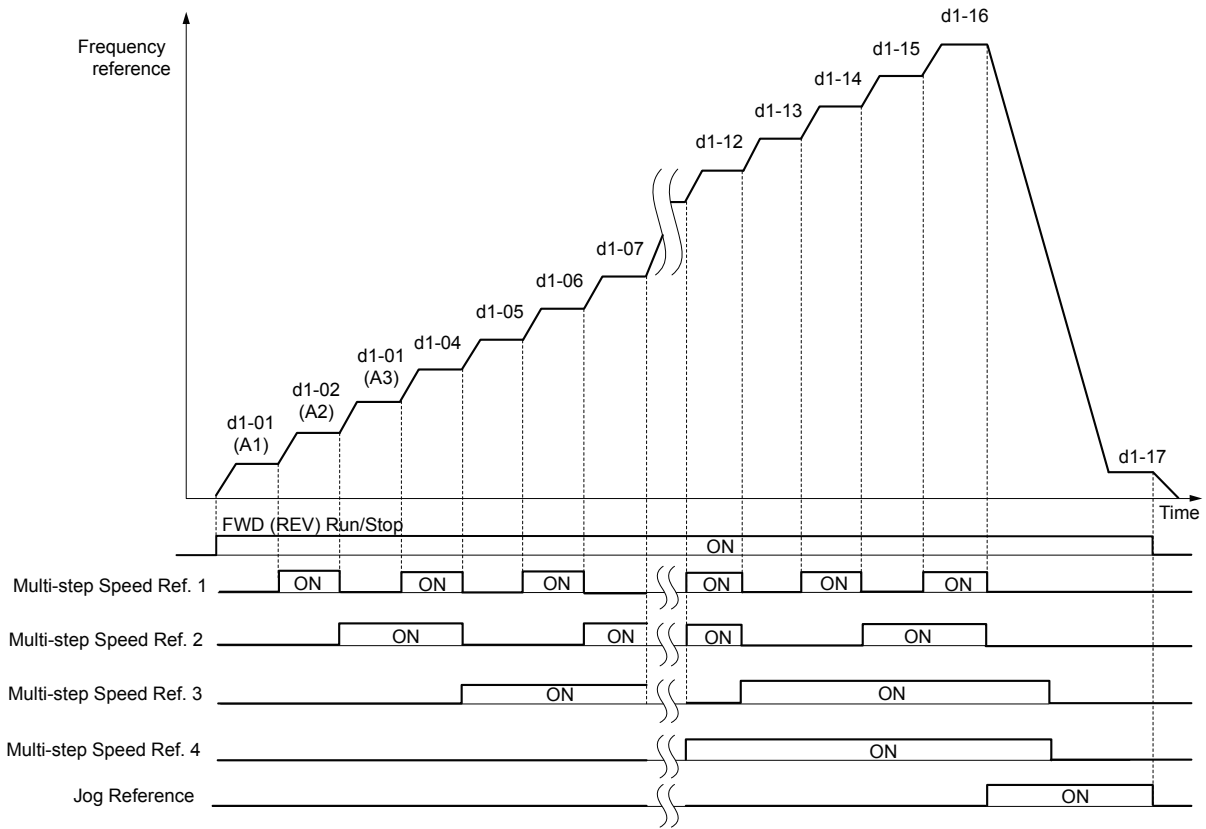

Figure 1.40 Preset Reference Timing Diagram

## ◆ d2: Frequency Upper/Lower Limits

Upper and lower frequency limits prevent motor speed from going above or below levels that may cause resonance or equipment damage.

### ■ d2-01: Frequency Reference Upper Limit

Sets the maximum frequency reference as a percentage of the maximum output frequency. This limit applies to all frequency references.

Even if the frequency reference is set to a higher value, the drive internal frequency reference will not exceed this value.

No.	Parameter Name	Setting Range	Default
d2-01	Frequency Reference Upper Limit	0.0 to 110.0%	100.0%

### ■ d2-02: Frequency Reference Lower Limit

Sets the minimum frequency reference as a percentage of the maximum output frequency. This limit applies to all frequency references.

If a lower reference than this value is entered, the drive will run at the limit set to d2-02. If the drive is started with a lower reference than d2-02, it will accelerate up to d2-02.

No.	Parameter Name	Setting Range	Default
d2-02	Frequency Reference Lower Limit	0.0 to 110.0%	0.0%

## 1.4 d: Reference Settings

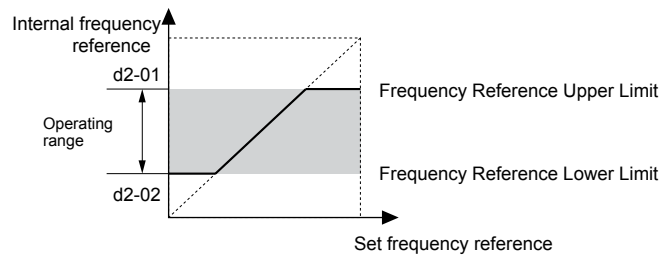

Figure 1.41 Frequency Reference: Upper and Lower Limits

### ■ d2-03: Master Speed Reference Lower Limit

Sets a lower limit as a percentage of the maximum output frequency that will only affect a frequency reference entered from the analog input terminals (A1, A2, or A3). This is unlike parameter d2-02, which affects all frequency references regardless of their source.

**Note:** When lower limits are set to both parameters d2-02 and d2-03, the drive uses the greater of those two values as the lower limit.

No.	Parameter Name	Setting Range	Default
d2-03	Master Speed Reference Lower Limit	0.0 to 110.0%	0.0%

### ◆ d3: Jump Frequency

#### ■ d3-01 to d3-04: Jump Frequencies 1, 2, 3 and Jump Frequency Width

The Jump frequencies are frequency ranges at which the drive will not operate. The drive can be programmed with three separate Jump frequencies to avoid operating at speeds that cause resonance in driven machinery. If the speed reference falls within a Jump frequency dead band, the drive will clamp the frequency reference just below the dead band and only accelerate past it when the frequency reference rises above the upper end of the dead band.

Setting parameters d3-01 through d3-03 to 0.0 Hz disables the Jump frequency function.

No.	Parameter Name	Setting Range	Default
d3-01	Jump Frequency 1	0.0 to 150.0 Hz <1>	0.0 Hz <1>
d3-02	Jump Frequency 2	0.0 to 150.0 Hz <1>	0.0 Hz <1>
d3-03	Jump Frequency 3	0.0 to 150.0 Hz <1>	0.0 Hz <1>
d3-04	Jump Frequency Width	0.0 to 20.0 Hz <1>	1.0 Hz <1>

<1> In AOLV/PM and CLV/PM control modes, the setting units and range are expressed as a percentage instead of in Hz.

Figure 1.42 shows the relationship between the Jump frequency and the output frequency.

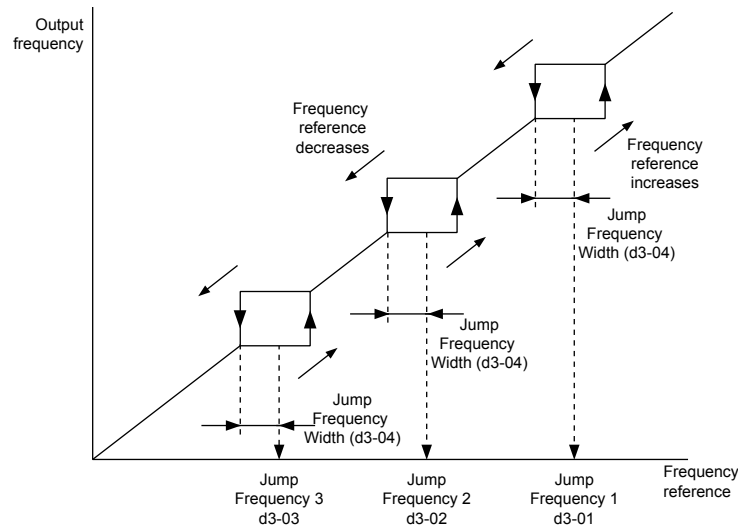

Figure 1.42 Jump Frequency Operation

- Note:**
1. The drive will use the active accel/decel time to pass through the specified dead band range, but will not allow continuous operation in that range.
  2. When setting more than one Jump frequency, make sure that  $d3-01 \geq d3-02 \geq d3-03$ .

## ◆ d4: Frequency Reference Hold and Up/Down 2 Function

### ■ d4-01: Frequency Reference Hold Function Selection

Determines whether the frequency reference or the frequency bias (Up/Down 2) value is saved when the Stop command is entered or the power supply is shut down. This parameter is effective when either of the digital input functions listed below are used:

- Accel/decel ramp hold function (H1-□□ = A)
- Up/Down function (H1-□□ = 10 and 11)
- Up/Down 2 function (H1-□□ = 75 and 76)

No.	Parameter Name	Setting Range	Default
d4-01	Frequency Reference Hold Function Selection	0, 1	0

The operation depends on the function used with parameter d4-01.

#### Setting 0: Disabled

- Acceleration hold

The hold value will be reset to 0 Hz when the Stop command is entered or the drive power is switched off. The active frequency reference will be the value the drive uses when it restarts.

- Up/Down

The frequency reference value will be reset to 0 Hz when the Stop command is entered or the drive power is switched off. The drive will start from 0 Hz when it is restarted.

- Up/Down 2

The frequency bias is not saved when the Stop command is entered, or 5 s after the Up/Down 2 command has been released. The Up/Down 2 function will start with a bias of 0% when the drive is restarted.

#### Setting 1: Enabled

- Acceleration hold

The last hold value will be saved when the Run command or the drive power is switched off and the drive will use the saved value as the frequency reference when it restarts. Make sure to continuously enable the multi-function input terminal set for “Accel/decel ramp hold” (H1-□□ = A) or the hold value will be cleared when the power is switched on.

## 1.4 d: Reference Settings

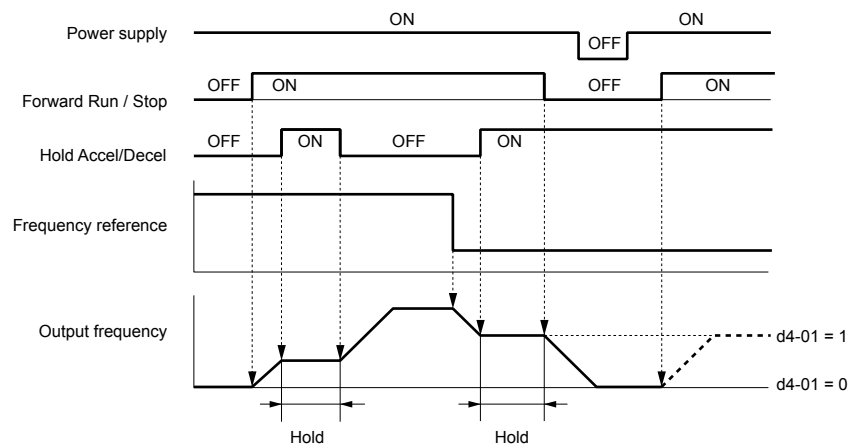

**Figure 1.43 Frequency Reference Hold with Accel/Decel Hold Function**

- Up/Down

The frequency reference value will be saved when the Run command or the drive power is switched off. The drive will use the frequency reference that was saved when it restarts.

- Up/Down 2 with frequency reference from digital operator

When a Run command is active and the Up/Down 2 command is released for longer than 5 s, the Up/Down 2 bias value is added to the frequency reference and then reset to 0. This new frequency reference is saved and will also be used to restart the drive after the power is cycled.

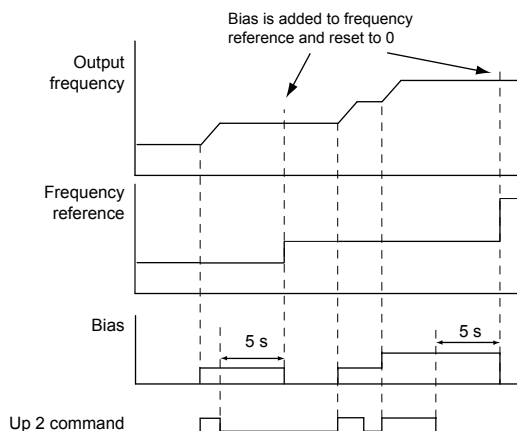

**Figure 1.44 Up/Down 2 Example with Reference from Digital Operator and d4-01 = 1**

- Up/Down 2 with frequency reference from input sources other than the digital operator

When a Run command is active and the Up/Down 2 command is released for longer than 5 s, the bias value will be saved in parameter d4-06. When restarting after the power is switched off, the drive will add the value saved in d4-06 as a bias to the frequency reference.



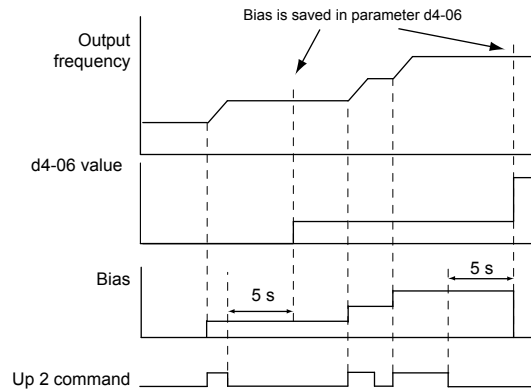

Figure 1.45 Up/Down 2 Example with Other Reference than Digital Operator and d4-01 = 1

**Note:** Set the limits for Up/Down 2 properly when using d4-01 = 1 in combination with the Up/Down 2 function. Refer to d4-08: Frequency Reference Bias Upper Limit (Up/Down 2) on page 67 and Refer to d4-09: Frequency Reference Bias Lower Limit (Up/Down 2) on page 67 for details on the limit settings.

### Clearing the Saved Value

Depending on which function is used, it is possible to clear the saved frequency reference value by:

- Releasing the input programmed for Acceleration hold.
- Setting an Up or Down command while no Run command is active.
- Resetting parameter d4-06 to zero. Refer to d4-06: Frequency Reference Bias (Up/Down 2) on page 66 for details.

### ■ d4-03: Frequency Reference Bias Step (Up/Down 2)

Sets the bias added to or subtracted from the frequency reference by the Up/Down 2 function.

No.	Parameter Name	Setting Range	Default
d4-03	Frequency Reference Bias Step (Up/Down 2)	0.00 to 99.99 Hz	0.00 Hz

The operation depends on the set value:

#### Setting d4-03 = 0.0 Hz

While the Up 2 or Down 2 command is enabled, the bias value is increased or decreased using the accel/decel times determined by parameter d4-04.

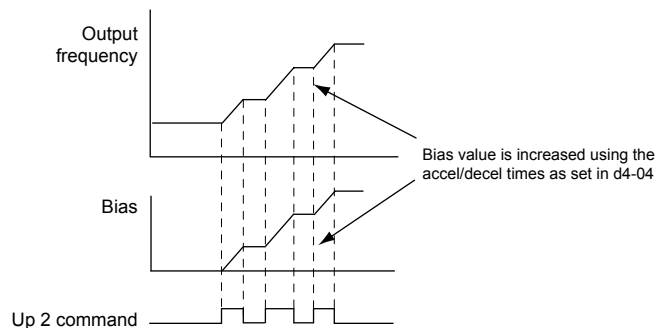

Figure 1.46 Up/Down 2 Bias when d4-03 = 0.0 Hz

#### Setting d4-03 ≠ 0.0 Hz

When an Up 2 or Down 2 command is enabled, the bias is increased or decreased in steps for the value set in d4-03. The frequency reference changes with the accel/decel times determined by parameter d4-04.

## 1.4 d: Reference Settings

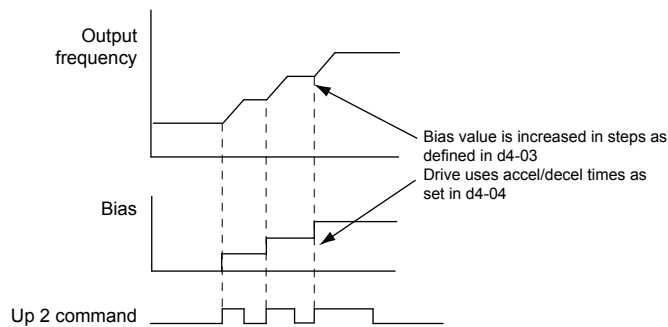

Figure 1.47 Up/Down 2 Bias when d4-03 > 0.0 Hz

### ■ d4-04: Frequency Reference Bias Accel/Decel (Up/Down 2)

Determines the accel/decel times used to increase or decrease the frequency reference or bias when using the Up/Down 2 function.

No.	Parameter Name	Setting Range	Default
d4-04	Frequency Reference Bias Accel/Decel (Up/Down 2)	0, 1	0

#### Setting 0: Current Accel/Decel Time

The drive uses the currently active accel/decel time.

#### Setting 1: Accel/Decel Time 4

The drive uses accel/decel time 4 set to parameters C1-07 and C1-08.

### ■ d4-05: Frequency Reference Bias Operation Mode Selection (Up/Down 2)

Determines if the bias value is held when the Up/Down 2 inputs are both released or both enabled. The parameter is effective only when parameter d4-03 is set to 0.00.

No.	Parameter Name	Setting Range	Default
d4-05	Frequency Reference Bias Operation Mode Selection (Up/Down 2)	0, 1	0

#### Setting 0: Hold Bias Value

The bias value will be held if no input Up 2 or Down 2 is active.

#### Setting 1: Reset Bias Value

The bias is reset to 0% when inputs Up 2 and Down 2 are both on or both off. The drive will use the accel/decel time as selected in d4-04 to accelerate or decelerate to the frequency reference value.

### ■ d4-06: Frequency Reference Bias (Up/Down 2)

Saves the frequency reference bias value set by the Up/Down 2 function as a percentage of the maximum output frequency. The function of this parameter depends on the Up/Down 2 function configuration. This parameter is not normally used when the digital operator sets the frequency reference.

- The value set to d4-06 will be applied during run, however the value is reset when the frequency reference changes (including multi-step references) and is disabled when d4-01 = 0 and the Run command is removed.
- When d4-01 = 0 and the frequency reference is set by a source other than the digital operator, the value set in d4-06 is added to or subtracted from the frequency reference.
- When d4-01 = 1 and the frequency reference is set by a source other than the digital operator, the bias value adjusted with the Up/Down 2 inputs is stored in d4-06 when 5 s have passed after releasing the Up 2 or Down 2 command. The frequency reference will return to the value without the Up/Down 2 command.

No.	Parameter Name	Setting Range	Default
d4-06	Frequency Reference Bias (Up/Down 2)	-99.9 to 100.0%	0.0%

#### Conditions that Reset or Disable d4-06

- The Up/Down 2 function has not been assigned to the multi-function terminals.
- The frequency reference source has been changed (including LOCAL/REMOTE or External reference 1/2 switch over by digital inputs).

- d4-03 = 0 Hz, d4-05 = 1, and the Up/Down 2 commands are both open or both closed.
- Any changes to the maximum frequency set to E1-04.

### ■ d4-07: Analog Frequency Reference Fluctuation Limit (Up/Down 2)

Handles frequency reference changes while the Up 2 or Down 2 terminal is enabled. If the frequency reference changes for more than the level set to d4-07, then the bias value will be held, and the drive will accelerate or decelerate following the frequency reference. When the frequency reference is reached, the bias hold is released and the bias follows the Up/Down 2 input commands.

This parameter is applicable only if the frequency reference is set by an analog or pulse input.

No.	Parameter Name	Setting Range	Default
d4-07	Analog Frequency Reference Fluctuation Limit (Up/Down 2)	0.1 to 100.0%	1.0%

### ■ d4-08: Frequency Reference Bias Upper Limit (Up/Down 2)

Sets the upper limit of the Up/Down 2 bias (monitor U6-20) and the value that can be saved in parameter d4-06. Set this parameter to an appropriate value before using the Up/Down 2 function.

**Note:** When the frequency reference is set by the digital operator (b1-01 = 0) and d4-01 = 1, the bias value will be added to the frequency reference if no Up/Down 2 command is received for 5 s, and will be reset to 0 afterwards. From that point, the bias can be increased up to the limit set in d4-08 again.

No.	Parameter Name	Setting Range	Default
d4-08	Frequency Reference Bias Upper Limit (Up/Down 2)	0.0 to 100.0%	100.0%

### ■ d4-09: Frequency Reference Bias Lower Limit (Up/Down 2)

Sets the lower limit of the Up/Down 2 bias (monitor U6-20) and the value that can be saved in parameter d4-06. Set this parameter to an appropriate value before using the Up/Down 2 function.

**Note:** When the frequency reference is set by the digital operator (b1-01 = 0) and d4-01 = 1, the bias value will be added to the frequency reference if no Up/Down 2 command is received for 5 s, and will be reset to 0 afterwards. If the bias is increased using the Up 2 command, it cannot be reduced with a Down 2 command when the limit set in d4-09 is 0. Set a negative lower limit in d4-09 to allow speed reduction in this situation.

No.	Parameter Name	Setting Range	Default
d4-09	Frequency Reference Bias Lower Limit (Up/Down 2)	-99.9 to 0.0%	0.0%

### ■ d4-10: Up/Down Frequency Reference Limit Selection

Selects how the lower frequency limit is set when using the Up/Down function. [Refer to Setting 10, 11: Up/Down Function on page 97](#) for details on the Up/Down function in combination with frequency reference limits.

No.	Parameter Name	Setting Range	Default
d4-10	Up/Down Frequency Reference Limit Selection	0, 1	0

#### Setting 0: Lower Limit is Determined by d2-02 or Analog Input

The higher value between d2-02 and an analog input programmed for Frequency bias (A1, A2, A3) determines the lower frequency reference limit.

**Note:** When using the External Reference 1/2 (H1-□□ = 2) to switch between the Up/Down function and an analog input as the reference source, the analog value becomes the lower reference limit when the Up/Down command is active. Set d4-10 to 1 to make the Up/Down function independent of the analog input value.

#### Setting 1: Lower Limit is Determined by d2-02

Only parameter d2-02 sets the lower frequency reference limit.

## ◆ d5: Torque Control

Torque Control defines a setpoint for the motor torque and is available for CLV and CLV/PM (A1-02 = 3, 7).

**Note:** PM motor control modes are not available in A1000 HHP drive models.

### ■ Torque Control Operation

Torque control can be enabled either by setting parameter d5-01 to 1 or by setting digital input (H1-□□ = 71). [Figure 1.48](#) illustrates the working principle.

## 1.4 d: Reference Settings

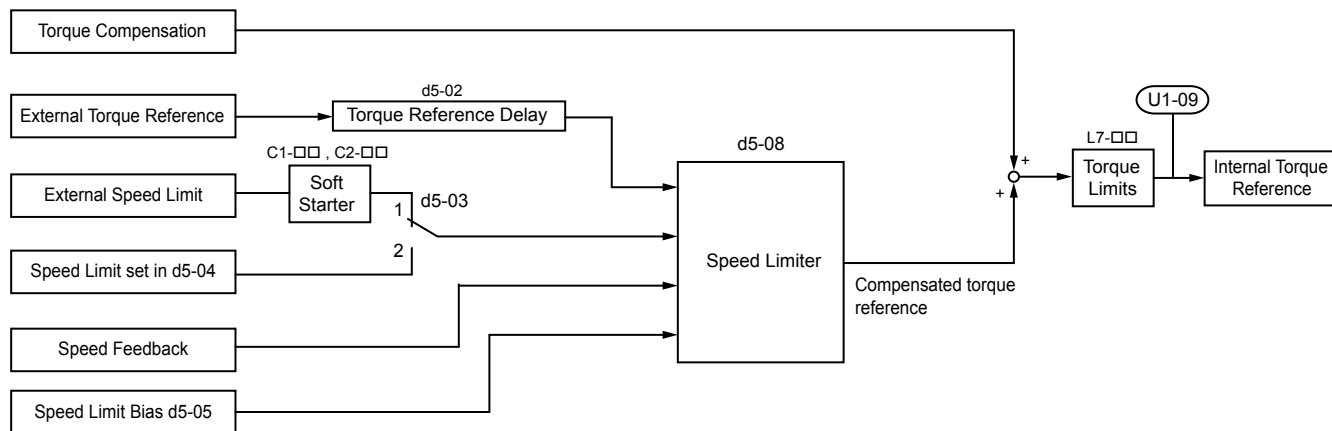

Figure 1.48 Torque Control Block Diagram

The externally input torque reference is the target value for the motor output torque. If the motor torque reference and the load torque are not in balance when in Torque Control, the motor accelerates or decelerates. To prevent operation beyond the speed limit, compensate the external torque reference value if the motor speed reaches the limit. The compensation value is calculated using the speed limit, speed feedback, and the speed limit bias.

If an external torque compensation value is input, it is added to the speed limit compensated torque reference value. The value calculated is limited by the L7-□□ settings, and is then used as the internal torque reference, which can be monitored in U1-09. The L7-□□ settings have highest priority. The motor cannot be operated with a higher torque than the L7-□□ settings even if the external torque reference value is increased.

### ■ Setting the Torque Reference, Speed Limit, and Torque Compensation Values

#### Torque Control Reference Sources

Set input values for Torque Control as explained in [Table 1.27](#).

Table 1.27 Torque Control Input Value Selection

Input Value	Signal Source	Settings	Remarks
Torque Reference	Analog inputs A1/A2/A3	H3-02, H3-06, or H3-10 = 13 </>	Match the input terminal signal level settings to the signal being used. <a href="#">Refer to H3: Multi-Function Analog Inputs on page 114</a> for details on adjusting analog input signals.
	Analog Option Card	<ul style="list-style-type: none"> <li>F2-01 = 0</li> <li>H3-02, H3-06, or H3-10 = 13 &lt;/&gt;</li> </ul>	The F3-□□ settings become effective for the option board input terminals. Match the input terminal signal level settings to the signal being used. <a href="#">Refer to H3: Multi-Function Analog Inputs on page 114</a> for details on adjusting analog input signals.
	MEMOBUS Register 0004H	Set Register 000FH, Bit 2 = 1 to enable Torque reference from register 0004H.	–
	Communication Option Card	F6-06 = 1 Refer to the option card manual for details about setting the torque compensation value.	–
Speed Limit	Signal selected as frequency reference source	d5-03 = 1 The speed limit is taken from the input selected as frequency reference source in parameter b1-01 or b1-15. </>	The settings in C1-□□ for accel/decel times and in C2-□□ for S-curves are applied to the speed limit value.
	Parameter d5-04	d5-03 = 2	–

Input Value	Signal Source	Settings	Remarks
Torque Compensation	Analog inputs A1/A2/A3	H3-02, H3-06, or H3-10 = 14 </>	Match the input terminal signal level settings to the signal being used. <i>Refer to H3: Multi-Function Analog Inputs on page 114</i> for details on adjusting analog input signals.
	Analog Option Card	<ul style="list-style-type: none"> <li>F2-01 = 0</li> <li>H3-02, H3-06, or H3-10 = 14 &lt;/&gt;</li> </ul>	The H3-□□ settings become effective for the option board input terminals. Match the input terminal signal level settings to the signal being used.
	MEMOBUS Register 0005H	Set Register 000FH, bit 3 = 1 to enable the torque compensation setting by register 0005H.	–
	Communication Option Card	F6-06 = 1 Refer to the option card manual for details about setting the torque compensation value.	–

</> Sets analog input terminals A1, A2, and A3 to supply the speed limit, torque reference, or torque compensation. Setting two analog inputs for the same function will trigger an oPE error.

**Input Value Polarity**

The direction of the input values described above depends on the polarity of the Run command and the input value.

**Table 1.28 Torque Control Signal Polarity**

Run Command Direction	Input Value Polarity	Input Value Direction
Forward	+ (positive)	Forward direction
	- (negative)	Reverse direction
Reverse	+ (positive)	Reverse direction
	- (negative)	Forward direction

*Example:*

- The internal torque reference will be positive (forward) with a Forward run command and a positive torque reference signal.
- The internal torque reference will be negative (reverse) with a Forward run command and a negative torque reference signal.

When using analog inputs, negative input values can be generated by:

- Applying negative voltage input signals.
- Using positive analog input signals while setting the analog input bias to negative values to make the input value negative.

When using MEMOBUS/Modbus communication or a communication option card, only positive input values can be set.

Independent of its input source, the polarity of the torque reference signal can be inverted using a digital input that is programmed for H1-□□ = 78. Use this function to input negative torque reference values when using MEMOBUS/Modbus or a communication option card.

**Speed Limitation and Speed Limit Bias**

The speed limit setting is read from the input selected in parameter d5-03. A bias can be added to this speed limit using parameter d5-05 while parameter d5-08 determines how the speed limit bias is applied. *Table 1.29* explains the relation between these settings.

**Table 1.29 Speed Limit, Speed Bias and Speed Limit Priority Selection**

Run Command	Operating Conditions			
	Forward	Forward	Forward	Forward
Torque Reference Direction	Positive (Forward)	Negative (Reverse)	Negative (Reverse)	Positive (Forward)
Speed Limit Direction	Positive (Forward)	Negative (Reverse)	Positive (Forward)	Negative (Reverse)
Normal Operation Direction	Forward	Reverse	Forward	Reverse

Parameter Details

1

## 1.4 d: Reference Settings

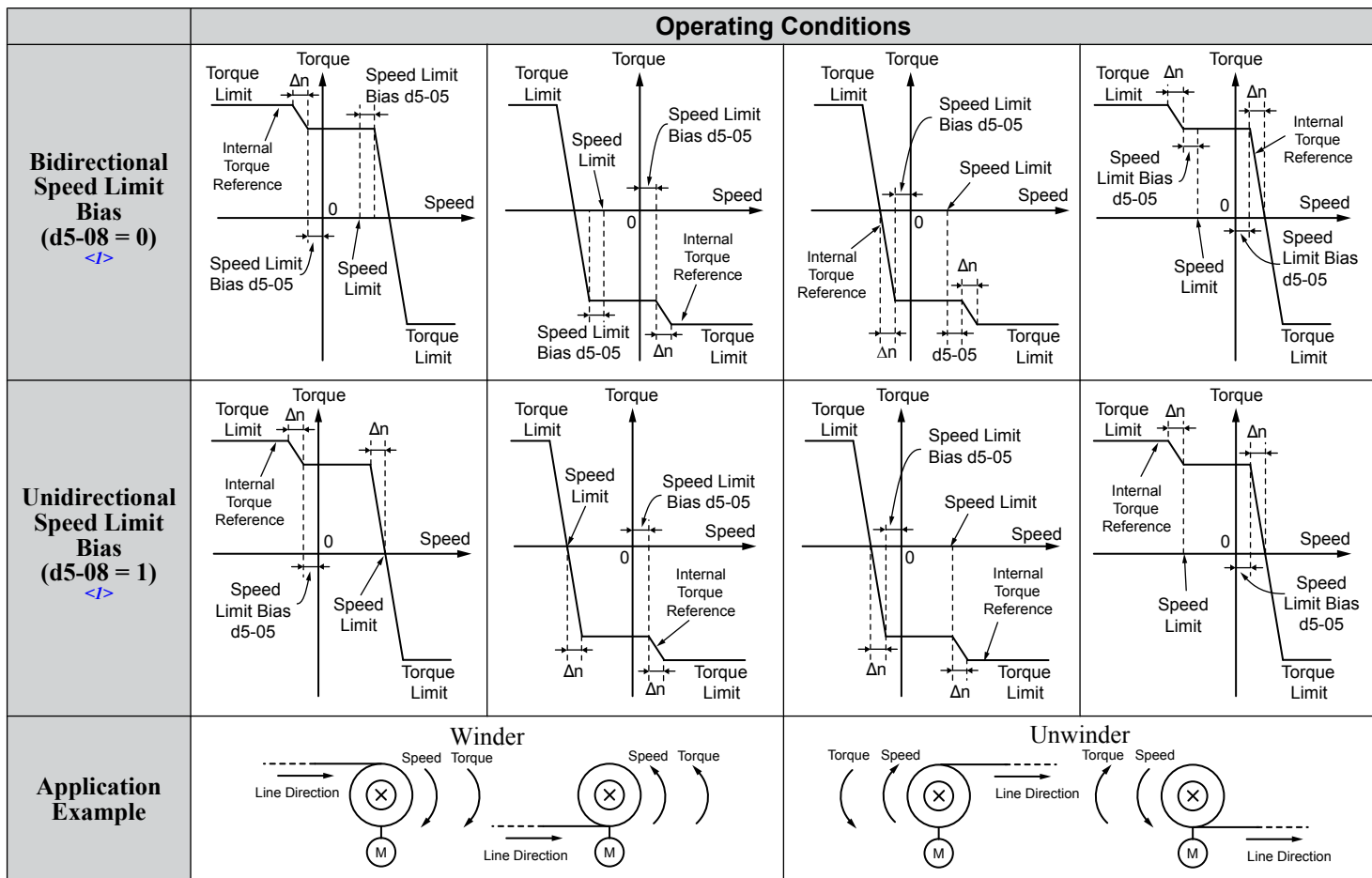

<1> The value of delta n in the drawings depends on the ASR setting in parameters C5-□□.

### ■ Indicating Operation at the Speed Limit

Program a digital output to close when the drive operates at or beyond the speed limit (H2-□□ = 32). Use this output to notify a control device such as a PLC of abnormal operating conditions.

### ■ Switching Between Torque and Speed Control

Use a digital output to switch Torque Control and Speed Control (H1-□□ = 71). When switching from Speed Control to Torque Control, the torque limit becomes the torque reference and the speed reference becomes the speed limit. This change is reversed when switching back to Speed Control.

If required by the application, set up a delay time using parameter d5-06. The reference values (torque reference/speed limit in Torque Control or speed reference/torque limit in Speed Control) are held during this switch delay time. Change the reference values from the controller within this delay time.

- Note:**
1. The switching delay time d5-06 is not applied when the Stop command is entered. Here the operation switches immediately to speed control and the drive decelerates to stop at the torque limit.
  2. Set d5-01 to 0 when switching between Torque Control and Speed Control. An oPE15 alarm will be triggered if parameter d5-01 is set to 1 while H1-□□ is set to 71 at the same time.

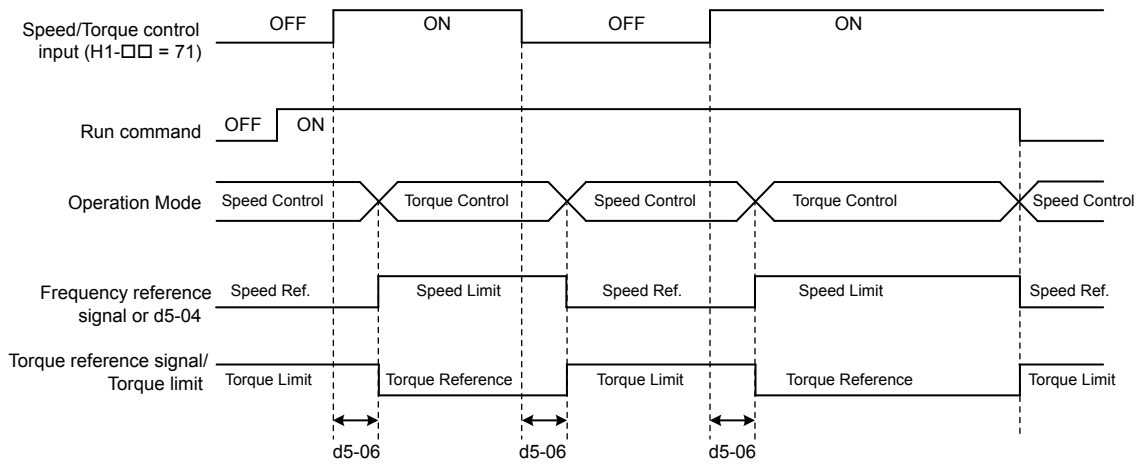

Figure 1.49 Speed/Torque Control Switching Time

■ **d5-01: Torque Control Selection**

No.	Parameter Name	Setting Range	Default
d5-01	Torque Control Selection	0, 1	0

**Setting 0: Disabled**

Speed Control will be active. Also use this setting when H1-□□ = 71 (Speed/Torque Control Switch).

**Setting 1: Enabled**

Torque Control is always enabled.

■ **d5-02: Torque Reference Delay Time**

Apply a filter with the time constant set to parameter d5-02 to the torque reference signal to eliminate oscillation resulting from an unstable torque reference signal. A higher filter time stabilizes control while reducing the responsiveness.

No.	Parameter Name	Setting Range	Default
d5-02	Torque Reference Delay Time	0 to 1000 ms	0 ms

■ **d5-03: Speed Limit Selection**

Determines how the speed limit is set.

No.	Parameter Name	Setting Range	Default
d5-03	Speed Limit Selection	1 or 2	1

**Setting 1: Frequency Reference Input**

The frequency reference value at the active reference source (digital operator, External reference 1 or External reference 2) will be used as speed limit. Note that in this case all settings for accel/decel times (C1-01 to C1-08) and S-curves (C2-01 to C2-04) will apply for the speed limit.

**Setting 2: d5-04**

The speed limit is set by parameter d5-04.

■ **d5-04: Speed Limit**

Sets the speed limit during torque control if parameter d5-03 is set to 2. *Refer to Speed Limitation and Speed Limit Bias on page 69.*

No.	Parameter Name	Setting Range	Default
d5-04	Speed Limit	-120 to 120%	0%

■ **d5-05: Speed Limit Bias**

Applies a bias set as a percentage of the maximum output frequency to the speed limit value. *Refer to Speed Limitation and Speed Limit Bias on page 69.*

## 1.4 d: Reference Settings

No.	Parameter Name	Setting Range	Default
d5-05	Speed Limit Bias	0 to 120%	10%

### ■ d5-06: Speed/Torque Control Switchover Time

Sets the delay time for switching between Speed Control and Torque Control.

No.	Parameter Name	Setting Range	Default
d5-06	Speed/Torque Control Switchover Time	0 to 1000 ms	0 ms

### ■ d5-08: Unidirectional Speed Limit Bias

Selects how the speed limit bias is applied.

No.	Parameter Name	Setting Range	Default
d5-08	Unidirectional Speed Limit Bias	0, 1	1

#### Setting 0: Disabled

The speed limit bias is applied in the speed limit direction and the opposite direction.

#### Setting 1: Enabled

The speed limit bias is applied in the opposite direction of the speed limit only.

## ◆ d6: Field Weakening and Field Forcing

### Field Weakening

The Field Weakening function reduces the output voltage to a predefined level to reduce the energy consumption of the motor. To activate the Field Weakening function, use a digital input programmed for H1-□□ = 63. Only use Field Weakening with a known and unchanging light load condition. Use the Energy Saving function (b8-□□ parameters) when Energy Saving for various different load conditions is required.

### Field Forcing

The Field Forcing function compensates the delaying influence of the motor time constant when changing the excitation current reference and improves motor responsiveness. Field Forcing is ineffective during DC Injection Braking.

### ■ d6-01: Field Weakening Level

Sets the level to which the output voltage is reduced when Field Weakening is activated. Set as percentage of the maximum output voltage.

No.	Parameter Name	Setting Range	Default
d6-01	Field Weakening Level	0 to 100%	80%

### ■ d6-02: Field Weakening Frequency Limit

Sets the lower limit (in Hz) of the frequency range where field weakening control is valid. The field weakening command is valid only at frequencies above this setting and only when output frequency is in agreement with the current output frequency (speed agree).

No.	Parameter Name	Setting Range	Default
d6-02	Field Weakening Frequency Limit	0 to 150.0 Hz	0.0 Hz



■ **d6-03: Field Forcing Selection**

Enables or disables the Field Forcing function.

No.	Parameter Name	Setting Range	Default
d6-03	Field Forcing Selection	0, 1	0

Setting 0: Disabled

Setting 1: Enabled

■ **d6-06: Field Forcing Limit**

Sets the maximum level at which the Field Forcing function can boost the excitation current reference. The value is set as a percentage of the motor no load current. This parameter does not normally need to be changed.

No.	Parameter Name	Setting Range	Default
d6-06	Field Forcing Limit	100 to 400%	400%

◆ **d7: Offset Frequency**

■ **d7-01 to d7-03: Offset Frequency 1 to 3**

Three different offset values can be added to the frequency reference. They can be selected using digital inputs programmed for Offset frequency 1, 2, and 3 (H1-□□ = 44, 45, 46). The selected offset values are added together if multiple inputs are closed simultaneously.

**Note:** This function can replace the “Trim Control” function (H1-□□ = 1C, 1D) of older Yaskawa drives.

No.	Parameter Name	Setting Range	Default
d7-01	Offset Frequency 1	-100.0 to 100.0%	0%
d7-02	Offset Frequency 2	-100.0 to 100.0%	0%
d7-03	Offset Frequency 3	-100.0 to 100.0%	0%

Figure 1.50 illustrates the Offset frequency function.

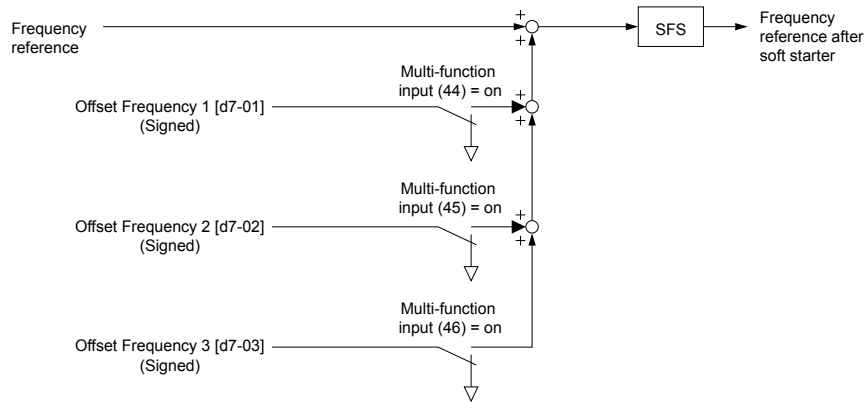

Figure 1.50 Offset Frequency Operation

## 1.5 E: Motor Parameters

E parameters cover V/f pattern and motor data settings.

### ◆ E1: V/f Pattern for Motor 1

#### ■ E1-01: Input Voltage Setting

Adjusts the levels of some protective features of the drive (overvoltage, Stall Prevention, etc.). Set this parameter to the nominal voltage of the AC power supply.

**NOTICE:** Set parameter E1-01 to match the input voltage of the drive. Drive input voltage (not motor voltage) must be set in E1-01 for the protective features to function properly. Failure to set the correct drive input voltage will result in improper drive operation.

No.	Parameter Name	Setting Range	Default
E1-01	Input Voltage Setting	310 to 510 V <1>	460 V <1>

<1> Values shown are specific to 400 V class drives. Multiply the values by 1.4375 for 575 V class drives. Multiply the values by 1.725 for 690 V class drives.

#### E1-01 Related Values

The input voltage setting determines the overvoltage and undervoltage detection levels, the operation levels of the braking transistor, the KEB function, and the overvoltage suppression function.

Voltage	Setting Value of E1-01	(Approximate Values)		
		Uv Detection Level (L2-05)	Desired DC Bus Voltage during KEB (L2-11)	ov Suppression / Stall Prevention Level (L3-17)
400 V Class	setting ≥ 400 V	380 Vdc	500 Vdc	750 Vdc
	setting < 400 V	350 Vdc	460 Vdc	750 Vdc
575 V Class	575 V	475 Vdc	635 Vdc	930 Vdc
690 V Class	794	570 Vdc	635 Vdc	930 Vdc

**Note:** The braking transistor operation levels are valid for the drive internal braking transistor. When using an external CDBR braking chopper, refer to the instruction manual of that unit.

#### ■ V/f Pattern Settings (E1-03)

The drive uses a V/f pattern to adjust the output voltage relative to the frequency reference. There are 15 different predefined V/f patterns (setting 0 to E) from which to select, each with varying voltage profiles, saturation levels (frequency at which maximum voltage is reached), and maximum frequencies. Additionally, one custom V/f pattern is available (setting F) that requires the user to create the pattern using parameters E1-04 through E1-10.

#### ■ E1-03: V/f Pattern Selection

Selects the V/f pattern for the drive and motor from 15 predefined patterns or creates a custom V/f pattern.

No.	Parameter Name	Setting Range	Default
E1-03	V/f Pattern Selection	0 to F <1>	F <2>

<1> Settings 0 through E are not available when A1-02 = 2, 3, 5, 6, or 7.

<2> Parameter is not reset to the default value when the drive is initialized using A1-03.

#### Setting a Predefined V/f Pattern (Setting 0 to E)

Choose the V/f pattern that best meets the application demands from the table below. These settings are available only in V/f Control modes. Set the correct value to E1-03. Parameters E1-04 to E1-13 can only be monitored, not changed.

- Note:**
1. Setting an improper V/f pattern may result in low motor torque or increased current due to overexcitation.
  2. Drive initialization does not reset parameter E1-03.

Table 1.30 Predefined V/f Patterns

Setting	Specification	Characteristic	Application
0	50 Hz	Constant torque	For general purpose applications. Torque remains constant regardless of changes to speed.
1	60 Hz		
2	60 Hz (with 50 Hz base)		
3	72 Hz (with 60 Hz base)		
4	50 Hz, Heavy Duty 2	Variable torque	For fans, pumps, and other applications where the required torque changes as a function of the speed.
5	50 Hz, Heavy Duty 1		
6	50 Hz, Heavy Duty 1		
7	50 Hz, Heavy Duty 2		
8	50 Hz, mid starting torque	High starting torque	Select high starting torque when: <ul style="list-style-type: none"> <li>• Wiring between the drive and motor exceeds 150 m.</li> <li>• A large amount of starting torque is required.</li> <li>• An AC reactor is installed.</li> </ul>
9	50 Hz, high starting torque		
A	60 Hz, mid starting torque		
B	60 Hz, high starting torque		
C	90 Hz (with 60 Hz base)	Constant output	Output voltage is constant when operating at greater than 60 Hz.
D	120 Hz (with 60 Hz base)		
E	150 Hz (with 60 Hz base)		
F </>	60 Hz	Constant torque	For general purpose applications. Torque remains constant regardless of changes to speed.

<1> Setting F enables a custom V/f pattern by changing parameters E1-04 to E1-13. When the drive is shipped, the default values for parameters E1-04 to E1-13 are the same as those of setting 1.

The following tables show details on predefined V/f patterns.

**Predefined V/f Patterns for all HHP models:**

- 400 V Class 414 A to 2000 A Heavy Duty, 466 A to 2250 A Normal Duty,
- 575 V Class 414 A to 2000 A Heavy Duty, 466 A to 2250 A Normal Duty,
- 690 V Class 414 A to 2000 A Heavy Duty, 466 A to 2250 A Normal Duty.

The values in the following graphs are specific to 400 V class drives. Multiply the values by 1.4375 for 575 V class drives. Multiply the values by 1.725 for 690 V class drives.

Table 1.31 Rated Torque Characteristics, Settings 0 to 3

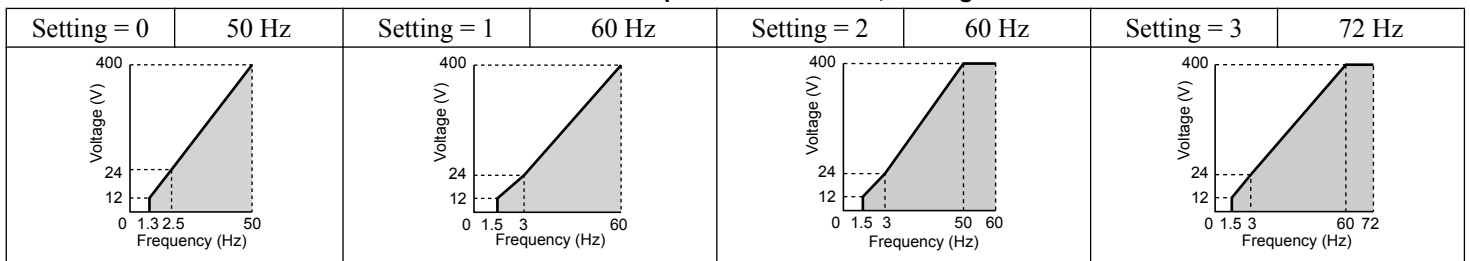
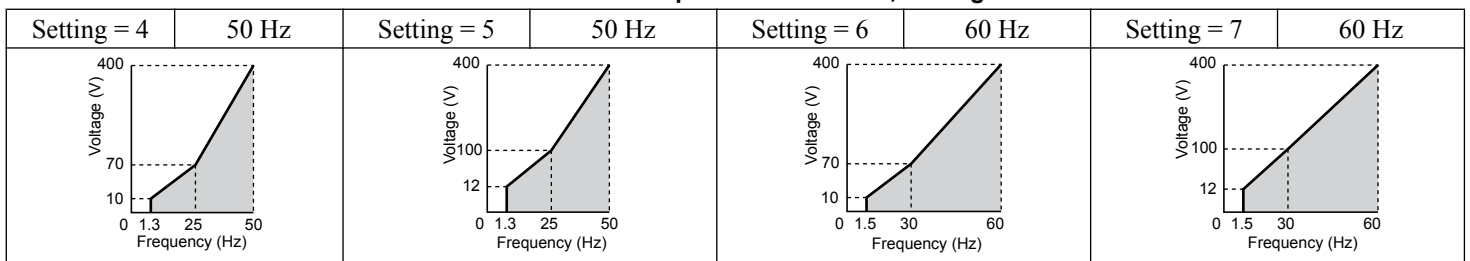
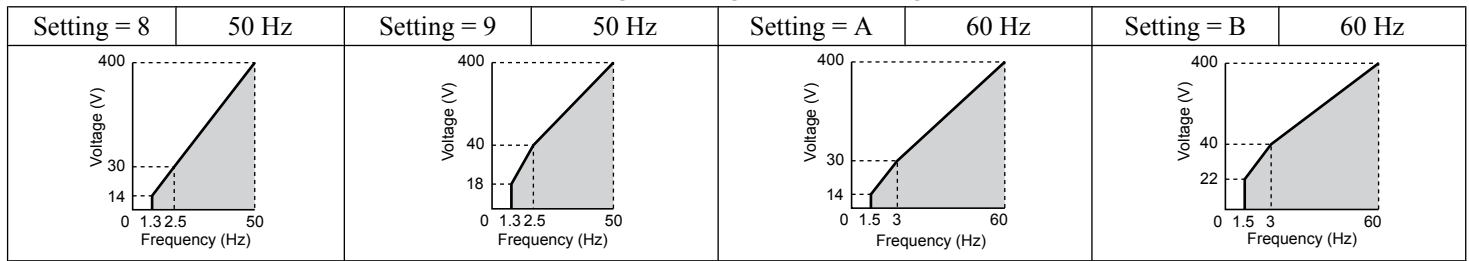

Table 1.32 Derated Torque Characteristics, Settings 4 to 7



## 1.5 E: Motor Parameters

**Table 1.33 High Starting Torque, Settings 8 to B**



**Table 1.34 Constant Output, Settings C to F**

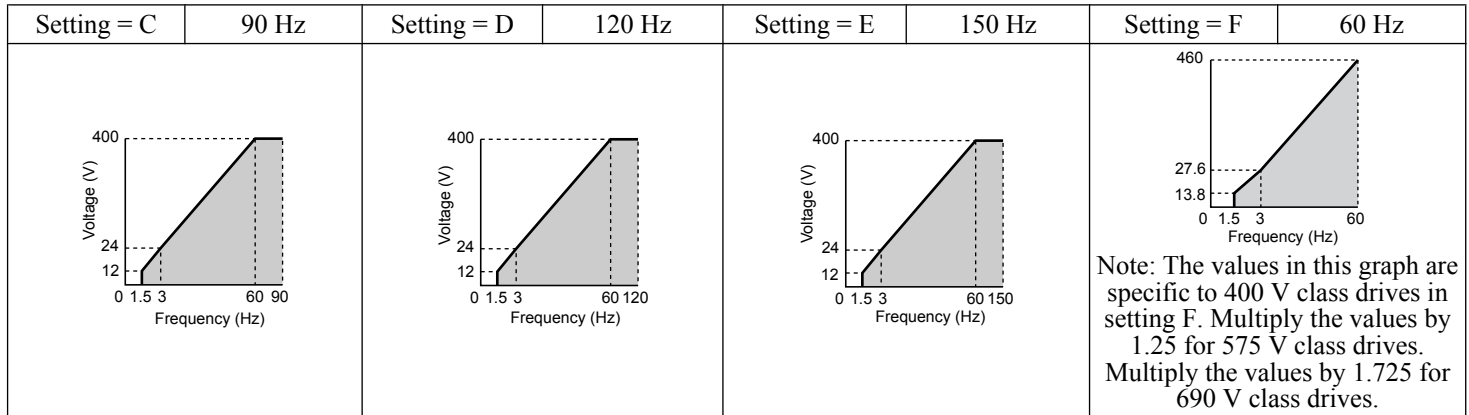

### Setting a Custom V/f Pattern (Setting F: Default)

Setting parameter E1-03 to F allows the user to set up a custom V/f pattern by changing parameters E1-04 to E1-13.

When initialized, the default values for parameters E1-04 to E1-13 will be equal to Predefined V/f pattern 1.

### ■ V/f Pattern Settings E1-04 to E1-13

If E1-03 is set to a preset V/f pattern (i.e., a value other than F), the user can monitor the V/f pattern in parameters E1-04 through E1-13. To create a new V/f pattern, set E1-03 to F. [Refer to V/f Pattern on page 77](#) for an example custom V/f pattern.

**Note:** Certain E1-□□ parameters might not be visible depending on the control mode. [Refer to Parameter List on page 231](#) for details.

No.	Parameter Name	Setting Range	Default
E1-04	Maximum Output Frequency	40.0 to 150.0 Hz	<1>
E1-05	Maximum Voltage	0.0 to 510.0 V <3>	<1>
E1-06	Base Frequency	0.0 to [E1-04]	<1>
E1-07	Middle Output Frequency	0.0 to [E1-04]	<1>
E1-08	Middle Output Frequency Voltage	0.0 to 510.0 V <3>	<1>
E1-09	Minimum Output Frequency	0.0 to [E1-04]	<1>
E1-10	Minimum Output Frequency Voltage	0.0 to 510.0 V <3>	<1>
E1-11	Middle Output Frequency 2	0.0 to [E1-04]	0.0 Hz <5>
E1-12	Middle Output Frequency Voltage 2	0.0 to 510.0 V <3>	0.0 V <4> <5>
E1-13	Base Voltage	0.0 to 510.0 V <3>	0.0 V <4>

<1> Default setting is determined by the control mode.

<2> When using PM motors, the default setting is determined by the motor code set to E5-01.

<3> Values shown are specific to 400 V class drives. Multiply the value by 1.4375 for 575 V class drives. Multiply the value by 1.725 for 690 V class drives.

<4> The drive changes these settings when Auto-Tuning is performed (Rotational Auto-Tuning, Stationary Auto-Tuning 1, 2).

<5> Parameter ignored when E1-11 and E1-12 are set to 0.0.

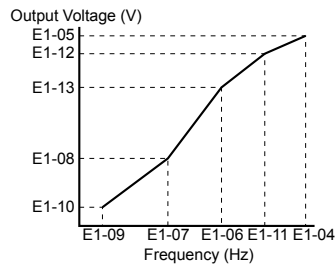

Figure 1.51 V/f Pattern

- Note:**
1. The following condition must be true when setting up the V/f pattern:  $E1-09 \leq E1-07 < E1-06 \leq E1-11 \leq E1-04$
  2. To make the V/f pattern a straight line below E1-06, set E1-09 equal to E1-07. In this case the E1-08 setting is disregarded.
  3. E1-03 is unaffected when the drive is initialized, but E1-04 through E1-13 return to their default values.
  4. Only use E1-11, E1-12, and E1-13 to fine-tune the V/f pattern in the constant output range. These parameters rarely need to be changed.

## ◆ E2: Motor 1 Parameters

These parameters contain the motor data needed for motor 1. Performing Auto-Tuning (including Rotational Auto-Tuning and Stationary Auto-Tuning 1 and 2) automatically sets these parameters. Manually enter the motor data into these parameters when Auto-Tuning cannot be performed.

**Note:** The function for switching between two motors cannot be used with a PM motor. E2-□□ parameters are hidden when a PM motor control mode is selected (A1-02 = 5, 6, or 7).

### ■ E2-01: Motor Rated Current

Provides motor control, protects the motor, and calculates torque limits. Set E2-01 to the full load amps (FLA) stamped on the motor nameplate. If Auto-Tuning completes successfully, the value entered to T1-04 will automatically be saved to E2-01.

No.	Parameter Name	Setting Range	Default
E2-01	Motor Rated Current	10% to 200% of the drive rated current	Determined by C6-01 and o2-04

- Note:**
1. The number of decimal places in the parameter value depends on the drive model and the ND/HD selection in parameter C6-01. This value has two decimal places (0.01 A) if the drive is set for a maximum applicable motor capacity up to and including 11 kW, and one decimal place (0.1 A) if the maximum applicable motor capacity is higher than 11 kW.
  2. An oPE02 error will occur if the motor rated current in E2-01 is set lower than the motor no-load current in E2-03. Set E2-03 correctly to prevent this error.

### ■ E2-02: Motor Rated Slip

Sets the motor rated slip in Hz to provide motor control, protect the motor, and calculate torque limits. This value is automatically set during Auto-Tuning (Rotational Auto-Tuning, Stationary Auto-Tuning 1 and 2).

No.	Parameter Name	Setting Range	Default
E2-02	Motor Rated Slip	0.00 to 20.00 Hz	Determined by C6-01 and o2-04

If Auto-Tuning cannot be performed, calculate the motor rated slip using the information written on the motor nameplate and the formula below:

$$E2-02 = f - (n \times p)/120$$

(f: rated frequency (Hz), n: rated motor speed (r/min), p: number of motor poles)

### ■ E2-03: Motor No-Load Current

Set the no-load current for the motor in amperes when operating at the rated frequency and the no-load voltage. The drive sets E2-03 during the Auto-Tuning process (Rotational Auto-Tuning and Stationary Auto-Tuning 1, 2). The motor no-load current listed in the motor test report can also be entered to E2-03 manually. Contact the motor manufacturer to receive a copy of the motor test report.

## 1.5 E: Motor Parameters

No.	Parameter Name	Setting Range	Default
E2-03	Motor No-Load Current	0 to [E2-01] (unit: 0.01 A)	Determined by C6-01 and o2-04

**Note:** The number of decimal places in the parameter value depends on the drive model and the ND/HD selection in parameter C6-01. This value has two decimal places (0.01 A) if the drive is set for a maximum applicable motor capacity up to and including 11 kW, and one decimal place (0.1 A) if the maximum applicable motor capacity is higher than 11 kW.

### ■ E2-04: Number of Motor Poles

Set the number of motor poles to E2-04. If Auto-Tuning completes successfully, the value entered to T1-06 will automatically be saved to E2-04.

No.	Parameter Name	Setting Range	Default
E2-04	Number of Motor Poles	2 to 48	4

### ■ E2-05: Motor Line-to-Line Resistance

Sets the line-to-line resistance of the motor stator winding. If Auto-Tuning completes successfully, this value is automatically calculated. Enter this value as line-to-line and not for each motor phase.

If Auto-Tuning is not possible, contact the motor manufacturer to find out the line-to-line resistance or measure it manually. When using the manufacturer motor test report, calculate E2-05 by one of the formulas below:

- E-type insulation: Multiply 0.92 times the resistance value ( $\Omega$ ) listed on the test report at 75 °C.
- B-type insulation: Multiply 0.92 times the resistance value ( $\Omega$ ) listed on the test report at 75 °C.
- F-type insulation: Multiply 0.87 times the resistance value ( $\Omega$ ) listed on the test report at 115 °C.

No.	Parameter Name	Setting Range	Default
E2-05	Motor Line-to-Line Resistance	0.000 to 65000 m $\Omega$ <I>	Determined by C6-01 and o2-04

<I> Units are expressed in m $\Omega$  for models CIMR-A□4A0930, 4A1200 and A1000 HHP.

### ■ E2-06: Motor Leakage Inductance

Sets the voltage drop due to motor leakage inductance as a percentage of motor rated voltage. This value is automatically set during Auto-Tuning (Rotational Auto-Tuning, Stationary Auto-Tuning 1, 2).

No.	Parameter Name	Setting Range	Default
E2-06	Motor Leakage Inductance	0.0 to 40.0%	Determined by C6-01 and o2-04

### ■ E2-07: Motor Iron-Core Saturation Coefficient 1

Sets the motor iron saturation coefficient at 50% of the magnetic flux. If Rotational Auto-Tuning completes successfully, then this value is automatically calculated and set to E2-07. This coefficient is used when operating with constant output.

No.	Parameter Name	Setting Range	Default
E2-07	Motor Iron-Core Saturation Coefficient 1	0.00 to 0.50	0.50

### ■ E2-08: Motor Iron-Core Saturation Coefficient 2

Sets the motor iron saturation coefficient at 75% of the magnetic flux. If Rotational Auto-Tuning completes successfully, then this value is automatically calculated and set to E2-08. This coefficient is used when operating with constant output.

No.	Parameter Name	Setting Range	Default
E2-08	Motor Iron-Core Saturation Coefficient 2	E2-07 to 0.75	0.75

### ■ E2-09: Motor Mechanical Loss

Sets the motor mechanical loss as a percentage of motor rated power (kW) capacity.

Adjust this setting in the following circumstances:

- When there is a large amount of torque loss due to motor bearing friction.
- When there is a large amount of torque loss in a fan or pump application.

The setting for the mechanical loss is added to the torque.

No.	Parameter Name	Setting Range	Default
E2-09	Motor Mechanical Loss	0.0 to 10.0%	0.0%

### ■ E2-10: Motor Iron Loss for Torque Compensation

Sets the motor iron loss in watts.

No.	Parameter Name	Setting Range	Default
E2-10	Motor Iron Loss for Torque Compensation	0 to 65535 W	Determined by C6-01 and o2-04

### ■ E2-11: Motor Rated Power

Sets the motor rated power in kW. If Auto-Tuning completes successfully, the value entered to T1-02 will automatically be saved to E2-11.

No.	Parameter Name	Setting Range	Default
E2-11	Motor Rated Power	0.00 to 650.00 kW	Determined by o2-04

**Note:** The display resolution depends on the rated output power of the drive after setting the Drive Duty in parameter C6-01. Drive models CIMR-A□2A0004 to 4A0515 display this value in units of 0.01 kW (two decimal places). Drive models CIMR-A□4A0675 to 4A1200 and HHP models display this value in units of 0.1 kW (one decimal place).

### ■ Setting Motor Parameters Manually

Follow the instructions below when setting motor-related parameters manually instead of Auto-Tuning. Refer to the motor test report included with the motor to ensure the correct data is entered into the drive.

#### Set the Motor Rated Current

Enter the motor rated current listed on the nameplate of the motor to E2-01.

#### Set the Motor Rated Slip

Calculate the motor rated slip using the base speed listed on the motor nameplate. Refer to the formula below, then enter that value to E2-02.

Motor rated slip = rated frequency [Hz] – base speed [r/min] × (no. of motor poles) / 120

#### Set the No-Load Current

Enter the no-load current at rated frequency and rated voltage to E2-03. This information is not usually listed on the nameplate. Contact the motor manufacturer if the data cannot be found.

The default setting of the no-load current is for performance with a 4-pole Yaskawa motor.

#### Set the Number of Motor Poles

Only required in V/f Control with PG and Closed Loop Vector Control. Enter the number of motor poles as indicated on motor nameplate.

#### Set the Line-to-Line Resistance

E2-05 is normally set during Auto-Tuning. If Auto-Tuning cannot be performed, contact the motor manufacturer to determine the correct resistance between motor lines. The motor test report can also be used to calculate this value using the formulas below:

- E-type insulation: Multiply 0.92 times the resistance value ( $\Omega$ ) listed on the test report at 75 °C.
- B-type insulation: Multiply 0.92 times the resistance value ( $\Omega$ ) listed on the test report at 75 °C.
- F-type insulation: Multiply 0.87 times the resistance value ( $\Omega$ ) listed on the test report at 115 °C.

#### Set the Motor Leakage Inductance

The motor leakage inductance set to E2-06 determines the amount of voltage drop relative to the motor rated voltage. Enter this value for motors with a low degree of inductance, such as high-speed motors. This information is usually not listed on the motor nameplate. Contact the motor manufacturer if the data cannot be found.

#### Set the Motor Iron-Core Saturation Coefficient 1, 2

E2-07 and E2-08 are set when Auto-Tuning is performed.

## 1.5 E: Motor Parameters

### Set the Motor Mechanical Loss

Only required in Closed Loop Vector Control. The drive compensates for the degree of mechanical loss with torque compensation. Although E2-09 rarely needs to be changed, adjustment may be necessary in the following circumstances:

- When there is a large amount of torque loss due to motor bearing friction.
- When there is a large amount of torque loss in a fan or pump application.

### Set the Motor Iron Loss for Torque Compensation

Only required when using V/f Control. Enter this value in watts to E2-10. The drive uses this setting to improve the precision of torque compensation.

## ◆ E3: V/f Pattern for Motor 2

These parameters set the V/f pattern used for motor 2. [Refer to Setting 16: Motor 2 Selection on page 99](#) for details on switching motors.

**Note:** The function for switching between two motors cannot be used with a PM motor. E3-□□ parameters are hidden when a PM motor control mode is selected (A1-02 = 5, 6, or 7).

### ■ E3-01: Motor 2 Control Mode Selection

Selects the control mode for motor 2. A control mode for PM motors cannot be selected for motor 2.

No.	Parameter Name	Setting Range	Default
E3-01	Motor 2 Control Mode Selection	0 to 3	0

**Note:** L1-01 determines protection from motor overload (oL1) in motor 2 and motor 1.

### Setting 0: V/f Control

### Setting 1: V/f Control with PG

### Setting 2: Open Loop Vector Control

### Setting 3: Closed Loop Vector Control

### ■ E3-04 to E3-13

Parameters E3-04 through E3-13 set up the V/f pattern used for motor 2 as shown in [Figure 1.52](#).

**Note:** Certain E3-□□ parameters might not be visible depending on the control mode. [Refer to Parameter List on page 231](#) for details.

No.	Parameter Name	Setting Range	Default
E3-04	Motor 2 Max Output Frequency	40.0 to 150.0 Hz	<2>
E3-05	Motor 2 Max Voltage	0.0 to 510.0 V <1>	<1> <2>
E3-06	Motor 2 Base Frequency	0.0 to [E3-04]	<2>
E3-07	Motor 2 Mid Output Frequency	0.0 to [E3-04]	<2>
E3-08	Motor 2 Mid Output Frequency Voltage	0.0 to 510.0 V <1>	<1> <2>
E3-09	Motor 2 Minimum Output Frequency	0.0 to [E3-04]	<2>
E3-10	Motor 2 Minimum Output Frequency Voltage	0.0 to 510.0 V <1>	<1> <2>
E3-11	Motor 2 Mid Output Frequency 2	0.0 to [E3-04]	0.0 Hz <4>
E3-12	Motor 2 Mid Output Frequency Voltage 2	0.0 to 510.0 V <1>	0.0 V <2> <3>
E3-13	Motor 2 Base Voltage	0.0 to 510.0 V <1>	0.0 V <3>

<1> Values shown are specific to 400 V class drives. Multiply the value by 1.4375 for 575 V class drives. Multiply the value by 1.725 for 690 V class drives.

<2> Default setting is determined by the control mode selected for motor 2 (E3-01).

<3> The drive sets this value when Auto-Tuning is performed (Rotational Auto-Tuning and Stationary Auto-Tuning 1, 2).

<4> Parameter ignored when E3-11 and E3-12 are set to 0.0.



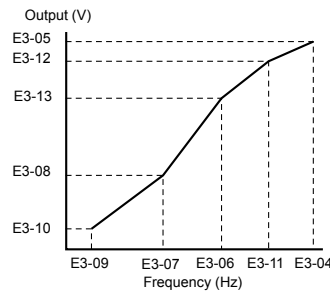

Figure 1.52 V/f Pattern for Motor 2

- Note:**
1. The following conditions must be true when setting up the V/f pattern:  $E3-09 \leq E3-07 < E3-06 \leq E3-11 \leq E3-04$
  2. To make the V/f pattern a straight line at a frequency lower than E3-07, set E3-09 equal to E3-07. In this case the E3-08 setting is disregarded.
  3. Parameters E3-04 through E3-13 are reset to their default values when the drive is initialized.
  4. Only use E3-11, E3-12, and E3-13 to fine-tune the V/f pattern in the constant output range. These parameters rarely need to be changed.

## ◆ E4: Motor 2 Parameters

E4 parameters contain the motor data for motor 2. These parameters are usually set automatically during the Auto-Tuning process for vector control modes (Rotational Auto-Tuning, Stationary Auto-Tuning 1 and 2). It may be necessary to set these parameters manually if there is a problem performing Auto-Tuning.

### ■ E4-01: Motor 2 Rated Current

Protects the motor and calculates torque limits. Set E4-01 to the full load amps (FLA) stamped on the nameplate of motor 2. If Auto-Tuning completes successfully, the value entered to T1-04 will automatically be saved to E4-01.

No.	Parameter Name	Setting Range	Default
E4-01	Motor 2 Rated Current	10 to 200% of the drive rated current.	Determined by C6-01 and o2-04

- Note:**
1. The number of decimal places in the parameter value depends on the drive model and the ND/HD selection in parameter C6-01. This value has two decimal places (0.01 A) if the drive is set for a maximum applicable motor capacity up to and including 11 kW, and one decimal place (0.1 A) if the maximum applicable motor capacity is higher than 11 kW.
  2. An oPE02 error will occur if the motor rated current in E4-01 is set lower than the motor no-load current in E4-03. Set E4-03 correctly to prevent this error.

### ■ E4-02: Motor 2 Rated Slip

Sets the motor 2 rated slip frequency and is the basis for slip compensation value. The drive calculates this value automatically during Auto-Tuning (Rotational Auto-Tuning and Stationary Auto-Tuning 1, 2).

*Refer to E2-02: Motor Rated Slip on page 77 for information on calculating the motor rated slip.*

No.	Parameter Name	Setting Range	Default
E4-02	Motor 2 Rated Slip	0.00 to 20.00 Hz	Determined by C6-01 and o2-04

### ■ E4-03: Motor 2 Rated No-Load Current

Sets the no-load current for motor 2 in amperes when operating at the rated frequency and the no-load voltage. The drive sets E2-03 during the Auto-Tuning process (Rotational Auto-Tuning and Stationary Auto-Tuning 1, 2). The motor no-load current listed in the motor test report can also be entered to E2-03 manually. Contact the motor manufacturer for a copy of the motor test report.

No.	Parameter Name	Setting Range	Default
E4-03	Motor 2 Rated No-Load Current	0 to [E4-01]	Determined by C6-01 and o2-04

- Note:** The number of decimal places in the parameter value depends on the drive model and the ND/HD selection in parameter C6-01. This value has two decimal places (0.01 A) if the drive is set for a maximum applicable motor capacity up to and including 11 kW, and one decimal place (0.1 A) if the maximum applicable motor capacity is higher than 11 kW.

## 1.5 E: Motor Parameters

### ■ E4-04: Motor 2 Motor Poles

Sets the number of poles for motor 2. If Auto-Tuning completes successfully, the value entered to T1-06 will be automatically saved to E4-04.

No.	Parameter Name	Setting Range	Default
E4-04	Motor 2 Motor Poles	2 to 48	4

### ■ E4-05: Motor 2 Line-to-Line Resistance

Sets the line-to-line resistance for the motor 2 stator winding. If Auto-Tuning completes successfully, this value is automatically calculated. Enter this value as line-to-line and not for each motor phase. *Refer to E2-05: Motor Line-to-Line Resistance on page 78* to manually enter this parameter setting.

No.	Parameter Name	Setting Range	Default
E4-05	Motor 2 Line-to-Line Resistance	0.000 to 65000 mΩ <1>	Determined by C6-01 and o2-04

<1> Units are expressed in mΩ for models CIMR-A□4A0930, 4A1200 and A1000 HHP.

### ■ E4-06: Motor 2 Leakage Inductance

Sets the voltage drop due to motor leakage inductance as a percentage of rated voltage of motor 2. This value is automatically set during Auto-Tuning (Rotational Auto-Tuning and Stationary Auto-Tuning 1, 2).

No.	Parameter Name	Setting Range	Default
E4-06	Motor 2 Leakage Inductance	0.0 to 40.0%	Determined by C6-01 and o2-04

### ■ E4-07: Motor 2 Motor Iron-Core Saturation Coefficient 1

Sets the motor 2 iron saturation coefficient at 50% of magnetic flux. This value is automatically set during Rotational Auto-Tuning. Adjust this parameter when operating in the constant output range.

No.	Parameter Name	Setting Range	Default
E4-07	Motor 2 Motor Iron-Core Saturation Coefficient 1	0.00 to 0.50	0.50

### ■ E4-08: Motor 2 Motor Iron-Core Saturation Coefficient 2

Sets the motor iron saturation coefficient at 75% of magnetic flux. This value is automatically set during Rotational Auto-Tuning. Adjust this parameter when operating in the constant output range.

No.	Parameter Name	Setting Range	Default
E4-08	Motor 2 Motor Iron-Core Saturation Coefficient 2	[E4-07] to 0.75	0.75

### ■ E4-09: Motor 2 Mechanical Loss

Sets the motor mechanical loss as a percentage of motor rated power (kW).

Although E4-09 rarely needs to be changed, adjustment may be necessary in the following circumstances:

- When there is a large amount of torque loss due to motor bearing friction.
- When there is a large amount of torque loss in a fan or pump application.

The setting for the mechanical loss is added to the torque.

No.	Parameter Name	Setting Range	Default
E4-09	Motor 2 Mechanical Loss	0.0 to 10.0%	0.0%

### ■ E4-10: Motor 2 Iron Loss

Sets the motor 2 iron loss in watts.

No.	Parameter Name	Setting Range	Default
E4-10	Motor 2 Iron Loss	0 to 65535 W	Determined by C6-01 and o2-04

### ■ E4-11: Motor 2 Rated Power

Sets the motor 2 rated power. If Auto-Tuning completes successfully, the value entered to T1-02 will automatically be saved to E4-11.

No.	Parameter Name	Setting Range	Default
E4-11	Motor 2 Rated Power	0.00 to 650.00 kW	Determined by o2-04

**Note:** The display resolution depends on the rated output power of the drive after setting the Drive Duty in parameter C6-01. Drive models CIMR-A□2A0004 to 4A0515 display this value in units of 0.01 kW (two decimal places). Drive models CIMR-A□4A0675 to 4A1200 and HHP models display this value in units of 0.1 kW (one decimal place).

## 1.6 F: Option Settings

### ◆ F1: PG Speed Control Card Settings

Yaskawa offers a PG-X3 and PG-B3 motor encoder PG option card. Use the CN5-C port when using only one PG option card and use the CN5-C and CN5-B ports when using two PG option cards. When programming one of the multi-function input terminals to act as a switch between two motors (H1-□□= 16), use the card connected to port CN5-C for motor 1 and use the card connected to CN5-B for motor 2.

[Table 1.35](#) lists the parameters that must be set for each option card port.

**Table 1.35 Option Card Ports and Corresponding Parameters**

Port	Parameters
CN5-C and CN5-B (common)	F1-02 to F1-04, F1-08 to F1-11, F1-14
CN5-C only	F1-01, F1-05, F1-06, F1-12, F1-13, F1-20 for A1000 HHP only, F1-21
CN5-B only	F1-31 to F1-37

#### ■ F1-01, F1-31: PG 1 and PG 2 Pulses Per Revolution

Sets the number encoder number of pulses per revolution.

No.	Parameter Name	Option Port	Setting Range	Default
F1-01	PG 1 Pulses Per Revolution	CN5-C	0 to 60000 ppr <1>	1024 ppr
F1-31	PG 2 Pulses Per Revolution	CN5-B	0 to 60000 ppr	1024 ppr

<1> Setting range is 0 to 15000 in PM motor control modes

#### ■ F1-02, F1-14: PG Open (PGo) Circuit Operation Selection, Detection Time

A PGo fault is triggered if the drive receives no pulse signal for longer than the time set in F1-14. Set the stopping method for a PGo fault in parameter F1-02.

No.	Parameter Name	Option Port	Setting Range	Default
F1-02	Operation Selection at PG Open Circuit (PGo)	CN5-B, CN5-C	0 to 3	1
F1-14	PG Open-Circuit Detection Time	CN5-B, CN5-C	0.0 to 10.0 s	2.0 s

##### Parameter F1-02 Settings:

**Setting 0: Ramp to stop (uses the deceleration time set to C1-02)**

**Setting 1: Coast to stop**

**Setting 2: Fast Stop (uses the Fast Stop time set to C1-09)**

**Setting 3: Alarm only**

**Note:** Due to potential damage to motor and machinery, refrain from using the “Alarm only” or “No alarm display” settings except under special circumstances.

**Setting 4: No alarm display**

**Note:** Due to potential damage to motor and machinery, refrain from using the “Alarm only” or “No alarm display” settings except under special circumstances.

#### ■ F1-03, F1-08, F1-09: Overspeed (oS) Operation Selection, Detection Level, Delay Time

An oS fault is triggered when the speed feedback exceeds the value set in F1-08 for longer than the time set in F1-09. Set the stopping method for an oS fault in parameter F1-03.

No.	Parameter Name	Option Port	Setting Range	Default
F1-03	Operation Selection at Overspeed (oS)	CN5-B, CN5-C	0 to 3	1
F1-08	Overspeed Detection Level	CN5-B, CN5-C	0 to 120%	115%
F1-09	Overspeed Detection Delay Time	CN5-B, CN5-C	0.0 to 2.0 s	Determined by A1-02

##### Parameter F1-03 Settings:

**Setting 0: Ramp to stop (uses the deceleration time set to C1-02)**

**Setting 1: Coast to stop****Setting 2: Fast Stop (uses the Fast Stop time set to C1-09)****Setting 3: Alarm only**

**Note:** Due to potential damage to motor and machinery, refrain from using the “Alarm only” setting except under special circumstances.

**■ F1-04, F1-10, F1-11: Operation at Speed Deviation (dEv), Detection Level, Delay Time**

A speed deviation error (dEv) is triggered when the difference between the frequency reference and the speed feedback exceeds the value set in F1-10 for longer than the time set in F1-1. The stopping method when a speed deviation fault occurs can be selected in parameter F1-04.

No.	Parameter Name	Option Port	Setting Range	Default
F1-04	Operation Selection at Deviation (dEv)	CN5-B, CN5-C	0 to 3	3
F1-10	Excessive Speed Deviation Detection Level	CN5-B, CN5-C	0 to 50%	10%
F1-11	Excessive Speed Deviation Detection Delay Time	CN5-B, CN5-C	0.0 to 10.0 s	0.5 s

**Settings for Parameter F1-04:****Setting 0: Ramp to stop (uses the deceleration time set to C1-02)****Setting 1: Coast to stop****Setting 2: Fast Stop (uses the Fast Stop time set to C1-09)****Setting 3: Alarm only (drive continues operating while “dEv” flashes on the screen)****■ F1-05, F1-32: PG 1, PG 2 Rotation Selection**

Determines the direction indicated by the pulses from the PG feedback encoder for motor 1 and motor 2.

See PG option card instruction manual for details on setting the direction for the PG encoder and the motor.

No.	Parameter Name	Option Port	Setting Range	Default
F1-05	PG 1 Rotation Selection	CN5-C	0, 1	0
F1-32	PG 2 Rotation Selection	CN5-B	0, 1	0

**Setting 0: A pulse leads with Forward run command****Setting 1: B pulse leads with Forward run command****■ F1-06, F1-35: PG 1, PG 2 Division Rate for PG Pulse Monitor**

Sets the ratio between the pulse input and the pulse output of a PG option card as a three-digit number, where the first digit (n) sets the numerator and the second and third digit (m) set the denominator as shown below:

$$f_{\text{Pulse Input}} = f_{\text{Pulse Output}} \cdot \frac{(1 + n)}{m}$$

Example: Set F1-06 to 032 for a ratio of 1/32 between the PG card pulse input and output.

No.	Parameter Name	Option Port	Setting Range	Default
F1-06	PG 1 Division Rate for PG Pulse Monitor	CN5-C	1 to 132 (1 to $\frac{1}{32}$ )	1
F1-35	PG 2 Division Rate for PG Pulse Monitor	CN5-B	1 to 132 (1 to $\frac{1}{32}$ )	1

**■ F1-12, F1-13, F1-33, F1-34: PG 1, PG 2 Gear Teeth 1, 2 (V/f w/PG only)**

Sets the gear ratio between the motor shaft and the PG encoder. F1-12 and F1-33 set the number of gear teeth on the motor side, while F1-13 and F-34 set the number of gear teeth on the load side. The drive uses the formula below to calculate the motor speed:

$$r/\text{min} = \frac{\text{Input pulses from PG} \cdot 60}{\text{Pulses per Rev (F1-01/31)}} \cdot \frac{\text{Load-side PG gear teeth (F1-12/33)}}{\text{Motor-side PG gear teeth (F1-13/34)}}$$

## 1.6 F: Option Settings

No.	Parameter Name	Option Port	Setting Range	Default
F1-12	PG 1 Gear Teeth 1	CN5-C	0 to 1000	0
F1-13	PG 1 Gear Teeth 2	CN5-C	0 to 1000	0
F1-33	PG 2 Gear Teeth 1	CN5-B	0 to 1000	0
F1-34	PG 2 Gear Teeth 2	CN5-B	0 to 1000	0

**Note:** A gear ratio of 1 will be used if any of these parameters are set to 0.

### ■ F1-20, F1-36: PG Option Card Disconnect Detection

Sets whether the drive detects a fault when a PG-X3 card is disconnected.

No.	Parameter Name	Option Port	Setting Range	Default
F1-20	PG Option Card Disconnection Detection 1	CN5-C	0, 1	1
F1-36	PG Option Card Disconnection Detection 2	CN5-B	0, 1	1

**Setting 0: Disabled**

**Setting 1: Enabled**

### ■ F1-21, F1-37: PG 1, PG 2 Signal Selection (V/f w/PG only)

Determines whether the signal to the PG option card is single-channel or two-channel.

No.	Parameter Name	Option Port	Setting Range	Default
F1-21	PG 1 Signal Selection	CN5-C	0, 1	0
F1-37	PG 2 Signal Selection	CN5-B	0, 1	0

**Setting 0: Single-channel (A channel only)**

**Setting 1: Two-channel (channels A and B)**

### ■ F1-30: PG Option Card Port for Motor 2 Selection

Specifies the drive port for the PG option card used for motor 2. Set this parameter when switching between motor 1 and motor 2, where both motors supply a speed feedback signal to the drive. Set F1-30 to 0 when using the same PG card for feedback signals from both motors. Set F1-30 to 1 when each motor has its own PG card connected to the drive.

**Note:** The motor 2 selection function cannot be used with PM motors.

No.	Parameter Name	Setting Range	Default
F1-30	PG Option Card Port for Motor 2 Selection	0, 1	1

**Setting 0: CN5-C**

**Setting 1: CN5-B**

## ◆ F2: Analog Input Card Settings

These parameters set the drive for operation with the analog input option card AI-A3. This section describes parameters that govern operation with an input option card. Refer to the option card instruction manual for specific details on installation, wiring, input signal level selection, and parameter setup.

### ■ F2-01: Analog Input Option Card Operation Selection

Determines how the input terminals on the AI-A3 option card are used.

No.	Parameter Name	Setting Range	Default
F2-01	Analog Input Option Card Operation Selection	0, 1	0

**Setting 0: Separate functions for each terminal (V1, V2, V3 replace terminals A1, A2, A3)**

Use the H3-□□ parameters described in [H3-03, H3-04: Terminal A1 Gain and Bias Settings](#) on page 114 to set the functions and gain and bias levels for an analog reference supplied by AI-A3.

**Note:** Setting option card terminals for separate input functions (F2-01 = 0) while b1-01 = 3 will cause an oPE05 error.

**Setting 1: Combine input terminal values to create frequency reference**

This setting adds all three input signals on the AI-A3 option card to create the frequency reference. Set b1-01 to 3 when the option card is the source of the frequency reference for the drive. Set the gain and bias settings for the frequency reference supplied from AI-A3 with F2-02 and F2-03.

**■ F2-02, F2-03: Analog Input Option Card Gain, Bias**

Parameter F2-02 sets the gain and parameter F2-03 sets the bias for the AI-A3 input signal when the card is used in the combined input signals mode (F2-01 = 1). Both gain and bias are set as a percentage of the maximum output frequency.

No.	Parameter Name	Setting Range	Default
F2-02	Analog Input Option Card Gain	-999.9 to 999.9%	100.0%
F2-03	Analog Input Option Card Bias	-999.9 to 999.9%	0.0%

**Note:** Enabled only when F2-01 = 1.

**◆ F3: Digital Input Card Settings**

These parameters set the drive for operation with the option card DI-A3. Refer to the instruction manual packaged with the option card for specific details on installation, wiring, input signal level selection, and parameter setup.

**■ F3-01: Digital Input Option Card Input Selection**

Determines the type of input for digital option card DI-A3 when o1-03 is set to 0 or 1.

No.	Parameter Name	Setting Range	Default
F3-01	Digital Input Option Card Input Selection	0 to 7	0

**Note:** BCD input when o1-03 = 2 or 3. Units are determined by o1-03.

**Setting 0: BCD, 1% units**

**Setting 1: BCD, 0.1% units**

**Setting 2: BCD, 0.01% units**

**Setting 3: BCD, 1 Hz units**

**Setting 4: BCD, 0.1 Hz units**

**Setting 5: BCD, 0.01 Hz units**

**Setting 6: BCD, special setting (5 digit input), 0.02 Hz units**

**Setting 7: Binary**

**■ F3-03: Digital Input Option DI-A3 Data Length Selection**

Determines the number of bits for the option card input that sets the frequency reference.

No.	Parameter Name	Setting Range	Default
F3-03	Digital Input Option DI-A3 Data Length Selection	0 to 2	2

**Setting 0: 8 bit**

**Setting 1: 12 bit**

**Setting 2: 16 bit**

**◆ F4: Analog Monitor Card Settings**

These parameters set the drive for operation with the analog output option card AO-A3. Refer to the instruction manual packaged with the option card for specific details on installation, wiring, input signal level selection, and parameter setup.

## 1.6 F: Option Settings

### ■ F4-01, F4-03: Terminal V1, V2 Monitor Selection

Selects the data to output from analog terminal V1. Enter the final three digits of U□-□□ to determine which monitor data is output from the option card. Some monitors are only available in certain control modes.

No.	Parameter Name	Setting Range	Default
F4-01	Terminal V1 Monitor Selection	000 to 999	102
F4-03	Terminal V2 Monitor Selection	000 to 999	103

### ■ F4-02, F4-04, F4-05, F4-06: Terminal V1, V2 Monitor Gain and Bias

Parameters F4-02 and F4-04 determine the gain, while parameters F4-05 and F4-06 set the bias. These parameters are set as a percentage of the output signal from V1 and V2 where 100% equals 10 V output. The terminal output voltage is limited to 10 V.

No.	Parameter Name	Setting Range	Default
F4-02	Terminal V1 Monitor Gain	-999.9 to 999.9%	100.0%
F4-04	Terminal V2 Monitor Gain	-999.9 to 999.9%	50.0%
F4-05	Terminal V1 Monitor Bias	-999.9 to 999.9%	0.0%
F4-06	Terminal V2 Monitor Bias	-999.9 to 999.9%	0.0%

#### Using Gain and Bias to Adjust Output Signal Level

When viewing the values set to F4-02 or F4-05 on the digital operator, a voltage equal to 100% of the parameter being viewed (including current gain and bias settings) will be output from terminal V1 or V2. When viewing the value set to F4-05 or F4-06, terminal V1 or V2 will output a voltage equal to 0% of the parameter being viewed (including current gain and bias settings).

Example 1: F4-02 = 0%, F4-02 = 80%. When the parameter setting display for F4-02 is accessed using the digital operator, terminal V1 will output a voltage of 8 V, even when the drive is stopped.

Example 2: F4-03 = 5%. When the parameter setting display for F4-03 is accessed using the digital operator, terminal V1 will output a voltage of 0.5 V, even when the drive is stopped.

### ■ F4-07, F4-08: Terminal V1, V2 Signal Level

Sets the output signal level for terminals V1 and V2.

No.	Parameter Name	Setting Range	Default
F4-07	Terminal V1 Signal Level	0, 1	0
F4-08	Terminal V2 Signal Level	0, 1	0

Setting 0: 0 to 10 V

Setting 1: -10 to 10 V

## ◆ F5: Digital Output Card Settings

These parameters set the drive for operation with the digital output option card DO-A3. Refer to the instruction manual packaged with the option card for specific details on installation, wiring, input signal level selection, and parameter setup.

### ■ F5-01 through F5-08: Digital Output Option Card Terminal Function Selection

When F5-09 = 2, the parameters listed in the table below assign functions to the output terminals on the option card.

No.	Name	Setting Range	Default
F5-01	Terminal P1-PC Output Selection	0 to 192	2: Speed agree
F5-02	Terminal P2-PC Output Selection	0 to 192	4: Frequency detection 1
F5-03	Terminal P3-PC Output Selection	0 to 192	6: Drive ready
F5-04	Terminal P4-PC Output Selection	0 to 192	37: During frequency output
F5-05	Terminal P5-PC Output Selection	0 to 192	F: Not used
F5-06	Terminal P6-PC Output Selection	0 to 192	F: Not used
F5-07	Terminal M1-M2 Output Selection	0 to 192	0: During run



No.	Name	Setting Range	Default
F5-08	Terminal M3-M4 Output Selection	0 to 192	1: Zero speed

### ■ F5-09: DO-A3 Output Mode Selection

Determines how the DO-A3 option card works with the drive.

No.	Parameter Name	Setting Range	Default
F5-09	DO-A3 Output Mode Selection	0 to 2	0

**Note:** Refer to TOBP C730600 41 Yaskawa AC Drive-Option DO-A3 Installation Manual for more details on F5-09 settings.

**Setting 0: Separate output functions for each of 8 terminals**

**Setting 1: Binary output**

**Setting 2: Output functions assigned by F5-01 through F5-08**

### ◆ F6: Communication Option Card

These parameters configure communication option cards and communication fault detection methods.

Some parameters apply to all communication option cards and some parameters apply to certain network options only. The option cards are applicable to the parameter rows marked with an “O”.

Parameter	Communication Protocol				
	CC-Link	MECHATROLINK-II	PROFIBUS-DP	CANopen	DeviceNet
F6-01 to F6-03, F6-06 to F6-08	O	O	O	O	O
F6-04, F6-10, F6-11, F6-14	O	–	–	–	–
F6-20 to F6-26	–	O	–	–	–
F6-30 to F6-32	–	–	O	–	–
F6-35 to F6-36	–	–	–	O	–
F6-50 to F6-63	–	–	–	–	O

### ■ F6-01: Communications Error Operation Selection

Determines drive operation when a communication error occurs.

No.	Parameter Name	Setting Range	Default
F6-01	Communications Error Operation Selection	0 to 3	1

**Setting 0: Ramp to stop (uses the deceleration time set to C1-02)**

**Setting 1: Coast to stop**

**Setting 2: Fast Stop (uses the Fast Stop time set to C1-09)**

**Setting 3: Alarm only (continue operation)**

### ■ F6-02: External Fault from Comm. Option Detection Selection

Determines the detection method of an external fault initiated by a communication option (EF0).

No.	Parameter Name	Setting Range	Default
F6-02	External Fault from Comm. Option Detection Selection	0, 1	0

**Setting 0: Always detected**

**Setting 1: Detection during run only**

### ■ F6-03: External Fault from Comm. Option Operation Selection

Determines drive operation when an external fault is initiated by a communication option (EF0).

## 1.6 F: Option Settings

No.	Parameter Name	Setting Range	Default
F6-03	External Fault from Comm. Option Operation Selection	0 to 3	1

**Setting 0: Ramp to stop**

**Setting 1: Coast to stop**

**Setting 2: Fast Stop**

**Setting 3: Alarm only (continue operation)**

### ■ F6-06: Torque Reference/Torque Limit Selection from Comm. Option

Selects whether torque reference and torque limit values are assigned to the drive from the network.

No.	Parameter Name	Setting Range	Default
F6-06	Torque Reference/Torque Limit Selection from Comm. Option	0, 1	0

**Setting 0: Enabled**

**Setting 1: Disabled**

### ■ F6-07: NetRef/ComRef Function Selection

Selects the treatment of multi-step speed inputs when the NetRef command is set.

No.	Parameter Name	Setting Range	Default
F6-07	NetRef/ComRef Function Selection	0, 1	0

**Setting 0: Multi-step speed operation disabled**

Multi-step speed input frequency references are disabled when the NetRef command is selected.

**Setting 1: Multi-step speed operation enabled**

Multi-step speed inputs are still active and can override the frequency reference from the communications option even when the NetRef command is selected.

### ■ F6-08: Reset Communication Parameters

Determines whether F6-□□ communication-related parameters are reset after initialization.

No.	Parameter Name	Setting Range	Default
F6-08	Reset Communication Parameters	0, 1	0

**Setting 0: Do not reset F6-□□ parameters after initialization using A1-03**

**Setting 1: Reset F6-□□ parameters after initialization using A1-03**

**Note:** F6-08 is not reset when the drive is initialized, but does determine whether initializing the drive resets the other F6-□□ communication parameters.

## ◆ CC-Link Parameters

Parameters F6-04, F6-10, F6-11, and F6-14 set the drive to operate on a CC-Link network.

### ■ F6-04: bUS Error Detection Time

Sets the delay time for bUS error detection.

No.	Parameter Name	Setting Range	Default
F6-04	bUS Error Detection Time	0.0 to 5.0 s	2.0 s

### ■ F6-10: CC-Link Node Address

Sets the node address of a CC-Link option board.

No.	Parameter Name	Setting Range	Default
F6-10	CC-Link Node Address	0 to 64	0

### ■ F6-11: CC-Link Communication Speed

Sets the communication speed for a CC-Link option card.

No.	Parameter Name	Setting Range	Default
F6-11	CC-Link Communication Speed	0 to 4	0

Settings:

F6-11	Communication Speed	F6-11	Communication Speed
0	156 kbps	3	5 Mbps
1	625 kbps	4	10 Mbps
2	2.5 Mbps	–	–

### ■ F6-14: CC-Link bUS Error Auto Reset

Selects whether a bUS error can be automatically reset if automatic fault retry is enabled.

No.	Parameter Name	Setting Range	Default
F6-14	CC-Link bUS Error Auto Reset	0, 1	0

**Setting 0: Disabled, auto reset not possible**

**Setting 1: Enabled, auto reset possible**

## ◆ PROFIBUS-DP Parameters

Parameters F6-30 through F6-32 set the drive to run on a PROFIBUS-DP network.

### ■ F6-30: PROFIBUS-DP Node Address

Sets the node address of a PROFIBUS-DP option card.

No.	Parameter Name	Setting Range	Default
F6-30	PROFIBUS-DP Node Address	0 to 125	0

### ■ F6-31: PROFIBUS-DP Clear Mode Selection

Determines the operation when a Clear Mode command is received.

No.	Parameter Name	Setting Range	Default
F6-31	PROFIBUS-DP Clear Mode Selection	0, 1	0

**Setting 0: Reset**

Resets the drive operation (frequency reference, inputs, outputs etc.).

**Setting 1: Maintain the previous state**

Returns the drive status to the state prior to receiving the command.

### ■ F6-32: PROFIBUS-DP Data Format Selection

Selects the data format used for PROFIBUS-DP communication.

No.	Parameter Name	Setting Range	Default
F6-32	PROFIBUS-DP Data Format Selection	0, 1	0

**Setting 0: PPO-type data format**

**Setting 1: Conventional data format**

## ◆ CANopen Parameters

Parameters F6-35 and F6-36 set the drive to operate on a CANopen network.

### ■ F6-35: CANopen Node ID Selection

Selects the node ID of a CANopen option board.

## 1.6 F: Option Settings

No.	Parameter Name	Setting Range	Default
F6-35	CANopen Node ID Selection	0 to 126	0

### ■ F6-36: CANopen Communication Speed

Sets the communication speed for a CANopen option card.

No.	Parameter Name	Setting Range	Default
F6-36	CANopen Communication Speed	0 to 8	6

#### Settings:

F6-36	Communication Speed	F6-36	Communication Speed
0	Auto detection	5	250 kbps
1	10 kbps	6	500 kbps
2	20 kbps	7	800 kbps
3	50 kbps	8	1 Mbps
4	125 kbps	–	–

## ◆ DeviceNet Parameters

Parameters F6-50 through F6-63 set the drive to operate on a DeviceNet network.

### ■ F6-50: DeviceNet MAC Address

Sets the MAC address for a DeviceNet option card.

No.	Parameter Name	Setting Range	Default
F6-50	DeviceNet MAC Address	0 to 64	64

### ■ F6-51: DeviceNet Communication Speed

Sets the communication speed for a DeviceNet option card.

To assign the baud rate for the drive from the upper controller, set F6-51 = 3.

To make the drive detect the network speed, set F6-51 = 4. The drive will automatically adjust itself after detecting the network speed.

No.	Parameter Name	Setting Range	Default
F6-51	DeviceNet Communication Speed	0 to 4	4

#### Settings:

F6-51	Communication Speed	F6-51	Communication Speed
0	125 kbps	3	Adjustable from Network
1	250 kbps	4	Auto detection
2	500 kbps	–	–

### ■ F6-52: DeviceNet PCA Setting

Defines the format for data the drive receives from the DeviceNet master.

No.	Parameter Name	Setting Range	Default
F6-52	DeviceNet PCA Setting	0 to 255	21

### ■ F6-53: DeviceNet PPA Setting

Defines the format for data sent from the drive to the DeviceNet master.

No.	Parameter Name	Setting Range	Default
F6-53	DeviceNet PPA Setting	0 to 255	71

### ■ F6-54: DeviceNet Idle Mode Fault Detection

Determines whether the drive triggers an EF0 fault when no data is received from the master (e.g., when the master is idling).

No.	Parameter Name	Setting Range	Default
F6-54	DeviceNet Idle Mode Fault Detection	0, 1	0

**Setting 0: Enabled**

**Setting 1: Disabled, no fault detection**

### ■ F6-55: DeviceNet Baud Rate Monitor

Displays the baud rate currently being used for network communications. F6-55 is used only as a monitor.

No.	Parameter Name	Setting Range	Default
F6-55	DeviceNet Baud Rate Monitor	0 to 2 (read only)	0

**Settings:**

F6-55	Communication Speed	F6-55	Communication Speed
0	125 kbps	2	500 kbps
1	250 kbps	–	–

### ■ F6-56 to F6-61: DeviceNet Scaling Factors

These parameters define scaling factors for drive monitors in the DeviceNet Class ID 2AH - AC/DC Drive Object.

No.	Parameter Name	Setting Range	Default
F6-56	DeviceNet Speed Scaling	-15 to 15	0
F6-57	DeviceNet Current Scaling	-15 to 15	0
F6-58	DeviceNet Torque Scaling	-15 to 15	0
F6-59	DeviceNet Power Scaling	-15 to 15	0
F6-60	DeviceNet Voltage Scaling	-15 to 15	0
F6-61	DeviceNet Time Scaling	-15 to 15	0

#### Setting

The monitor value in the AC/DC Drive Object 2AH is calculated by:

$$\text{AC/DC Drive Object 2AH Monitor} = \text{Drive Value} \times 2^{\text{Scaling}}$$

Example:

If the drive output frequency monitor (U1-02) is 5.00 and the scaling is set to F6-56 = 6, then the value in the AC/DC Drive Object 2AH, Instance 1, Attribute 7 would be  $500 \times 2^6 = 32000$ .

### ■ F6-62: DeviceNet Heartbeat Interval

Sets the heartbeat interval for DeviceNet communications. A setting of 0 disables the heartbeat function.

No.	Parameter Name	Setting Range	Default
F6-62	DeviceNet Heartbeat Interval	0 to 10	0

### ■ F6-63: DeviceNet Network MAC ID

Displays the MAC ID assigned to the drive. F6-63 is used only as a monitor.

No.	Parameter Name	Setting Range	Default
F6-63	DeviceNet Network MAC ID	0 to 63 (read only)	0

### ■ F6-64 to F6-71: Dynamic Assembly Parameters (Reserved)

# 1.7 H: Terminal Functions

H parameters assign functions to the external terminals.

## ◆ H1: Multi-Function Digital Inputs

### ■ H1-01 to H1-08: Functions for Terminals S1 to S8

These parameters assign functions to the multi-function digital inputs. The various functions and settings are listed in [Table 1.36](#).

No.	Parameter Name	Setting Range	Default
H1-01	Multi-Function Digital Input Terminal S1 Function Selection	1 to 9F	40 (F) <1> : Forward Run Command (2-Wire sequence)
H1-02	Multi-Function Digital Input Terminal S2 Function Selection	1 to 9F	41 (F) <1> : Reverse Run Command (2-Wire sequence)
H1-03	Multi-Function Digital Input Terminal S3 Function Selection	0 to 9F	24: External Fault
H1-04	Multi-Function Digital Input Terminal S4 Function Selection	0 to 9F	14: Fault Reset
H1-05	Multi-Function Digital Input Terminal S5 Function Selection	0 to 9F	3 (0) <1> : Multi-Step Speed Reference 1
H1-06	Multi-Function Digital Input Terminal S6 Function Selection	0 to 9F	4 (3) <1> : Multi-Step Speed Reference 2
H1-07	Multi-Function Digital Input Terminal S7 Function Selection	0 to 9F	6 (4) <1> : Jog Reference Selection
H1-08	Multi-Function Digital Input Terminal S8 Function Selection	0 to 9F	8: External Baseblock Command

<1> Number appearing in parenthesis is the default value after performing a 3-Wire initialization.

**Table 1.36 Multi-Function Digital Input Terminal Settings**

Setting	Function	Page	Setting	Function	Page
0	3-Wire Sequence	95	20 to 2F	External Fault	100
1	LOCAL/REMOTE Selection	95	30	PID Integral Reset	101
2	External Reference 1/2 Selection	96	31	PID Integral Hold	101
3	Multi-Step Speed Reference 1	96	32	Multi-Step Speed Reference 4	101
4	Multi-Step Speed Reference 2		34	PID Soft Starter Cancel	101
5	Multi-Step Speed Reference 3		35	PID Input Level Selection	101
6	Jog reference Selection	96	40	Forward Run Command (2-Wire sequence)	101
7	Accel/Decel Time Selection 1	96	41	Reverse Run Command (2-Wire sequence)	
8	Baseblock Command (N.O.)	96	42	Run Command (2-Wire sequence 2)	102
9	Baseblock Command (N.C.)		43	FWD/REV Command (2-Wire sequence 2)	
A	Accel/Decel Ramp Hold	96	44	Offset Frequency 1	102
B	Drive Overheat Alarm (oH2)	97	45	Offset Frequency 2	
C	Analog Terminal Input Selection	97	46	Offset Frequency 3	
D	PG Encoder Disable	97	47	Node Setup	102
E	ASR integral reset	97	60	DC Injection Braking Command	102
F	Through Mode	97	61	External Speed Search Command 1	102
10	Up Command	97	62	External Speed Search Command 2	102
11	Down Command		63	Field Weakening	102
12	Forward Jog	98	65	KEB Ride-Thru 1 (N.C.)	102
13	Reverse Jog		66	KEB Ride-Thru 1 (N.O.)	
14	Fault Reset	98	67	Communications Test Mode	102
15	Fast Stop (N.O.)	98	6A	Drive Enabled	103
16	Motor 2 Selection	99	71	Speed/Torque Control Switch	103
17	Fast Stop (N.C.)	98	72	Zero Servo	103
18	Timer Function Input	99	75	Up 2 Command	103
19	PID Disable	100	76	Down 2 Command	
1A	Accel/Decel Time Selection 2	100	77	ASR Gain Switch	104
1B	Program Lockout	100	78	External Torque Reference Polarity Inversion	104
1E	Reference Sample Hold	100			

Setting	Function	Page
7E	Forward/Reverse Detection (V/f control with simple PG)	104
90 to 97	DriveWorksEZ Digital Input 1 to 8	104

Setting	Function	Page
9F	DriveWorksEZ Disabled	104

**Setting 0: 3-Wire Sequence**

The digital input programmed for 3-Wire control becomes the forward/reverse directional input, S1 becomes the Run command input, and S2 becomes the Stop command input.

The drive starts the motor when the input S1 set for the Run command closes for longer than 2 ms. The drive stops the operation when the Stop input S2 releases for 2 ms. When the digital input programmed for a forward/reverse operation is open, the drive is set for forward operation. When the digital input is closed, the drive is set for reverse operation.

**Note:** Input the Run and Stop commands via S1 and S2 when selecting a 3-Wire sequence.

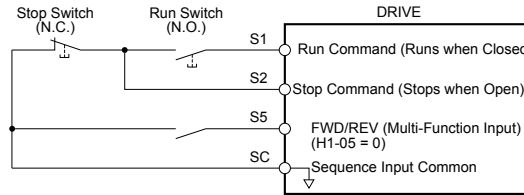

Figure 1.53 3-Wire Sequence Wiring Diagram

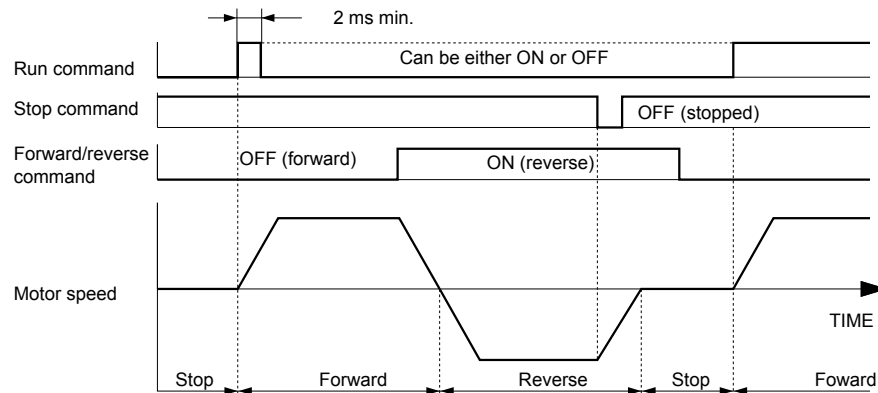

Figure 1.54 3-Wire Sequence

- Note:**
1. The Run command must be closed for more than 2 ms.
  2. If the Run command is active at power up and b1-17 = 0 (Run command at power up not accepted), the Run LED will flash to indicate that protective functions are operating. If required by the application, set b1-17 to 1 to automatically issue the Run command upon drive power up.

**WARNING! Sudden Movement Hazard.** Ensure start/stop and safety circuits are wired properly and in the correct state before applying power to the drive. Failure to comply could result in death or serious injury from moving equipment.

**WARNING! Sudden Movement Hazard.** The drive may start unexpectedly in reverse direction after power up if it is wired for 3-Wire sequence but set up for 2-Wire sequence (default). Make sure b1-17 is set to "0" (drive does not accept a Run command active at power up). When initializing the drive use 3-Wire initialization. Failure to comply could result in death or serious injury from moving equipment.

**Setting 1: LOCAL/REMOTE Selection**

This setting allows the input terminal to determine if the drive will run in LOCAL mode or REMOTE mode.

Status	Description
Closed	LOCAL: Frequency reference and Run command are input from the digital operator.
Open	REMOTE: Frequency reference and Run command are input from the selected external reference. If a digital input set to H1-□□ = 2 is active, they will be read from external reference source 2 (b1-15 and b1-16). In all other cases they will be read from external reference source 1 (b1-01 and b1-02).

- Note:**
1. The LO/RE key on the digital operator is disabled when one of the multi-function input terminals is set to for LOCAL/REMOTE.
  2. When the drive is set to LOCAL, the LO/RE LED will light.
  3. The default setting of the drive does not allow switching between LOCAL and REMOTE during run. To allow the drive to switch between LOCAL and REMOTE during run, [Refer to b1-07: LOCAL/REMOTE Run Selection on page 24.](#)

## 1.7 H: Terminal Functions

### Setting 2: External Reference 1/2 Selection

This function switches the Run command and frequency reference source between External reference 1 and 2 if the drive is in the REMOTE mode.

Status	Description
Open	External reference 1 is used (defined by parameters b1-01 and b1-02)
Closed	External reference 2 is used (defined by parameters b1-15 and b1-16)

**Note:** Default drive settings do not allow switching between External reference 1 and 2 during run. *Refer to b1-07: LOCAL/REMOTE Run Selection on page 24* if this feature is required by the application.

### Setting 3 to 5: Multi-Step Speed Reference 1 to 3

Switches multi-step speed frequency references d1-01 to d1-08 by digital inputs. *Refer to d1: Frequency Reference on page 59* for details.

### Setting 6: Jog Reference Selection

The Jog frequency set in parameter d1-17 becomes the frequency reference when the input terminal closes. *Refer to d1: Frequency Reference on page 59* for details.

### Setting 7: Accel/Decel Time Selection 1

Switches between accel/decel times 1 (C1-01 and C1-02) and 2 (C1-03 and C1-04). *Refer to C1-01 to C1-08: Accel, Decel Times 1 to 4 on page 46* for details.

### Setting 8, 9: Baseblock Command (N.O., N.C.)

When the drive receives a baseblock command, the output transistors stop switching, the motor coasts to stop, and a bb alarm flashes on the digital operator to indicate baseblock. When baseblock ends while a Run command is active, the drive performs Speed Search to restart the motor.

Digital Input Function	Drive Operation	
	Input Open	Input Closed
Setting 8 (N.C.)	Baseblock (Interrupt output)	Normal operation
Setting 9 (N.O.)	Normal operation	Baseblock (Interrupt output)

**WARNING! Sudden Movement Hazard.** When using a mechanical holding brake with the drive in a lifting application, close the brake when the drive output is cut off by a baseblock command triggered by one of the input terminals. Failure to comply will result in a slipping load from the motor suddenly coasting when the baseblock command is entered and may cause serious injury or death.

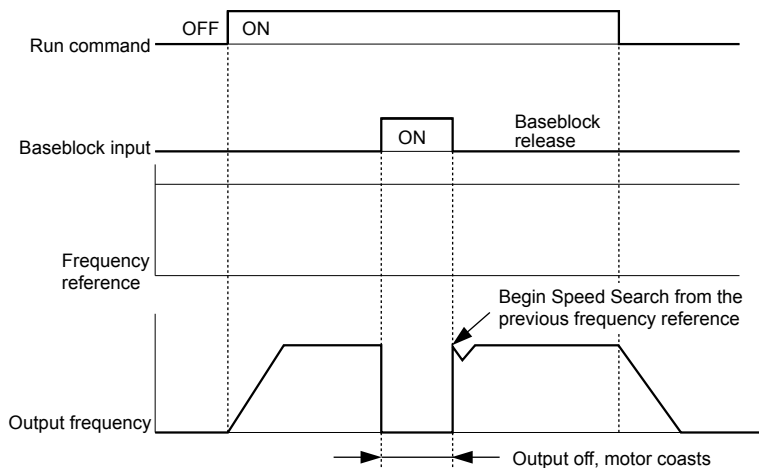

Figure 1.55 Baseblock Operation During Run

### Setting A: Accel/Decel Ramp Hold

When the digital input programmed for the Accel/decel ramp hold function closes, the drive locks (holds) the output frequency. Acceleration or deceleration resumes when the input is reopened.

If the Accel/decel ramp hold function is enabled (d4-01 = 1), the drive saves the output frequency to memory when the Ramp Hold input is closed. When the drive is restarted after stop or after power supply interruption, the saved output frequency becomes the frequency reference (provided that the Accel/decel ramp hold input is still closed). *Refer to d4-01: Frequency Reference Hold Function Selection on page 63* for details.



**Setting B: Drive Overheat Alarm (oH2)**

Triggers an oH2 alarm when the contact closes. Drive operation is not affected because this is an alarm.

**Setting C: Analog Terminal Input Selection (Terminal A1, A2, A3)**

When closed, the terminals specified in H3-14 are enabled. When open, the drive disregards the input signal to the analog terminals.

**Setting D: PG Encoder Disable**

When closed, the drive disregards PG feedback from the motor when using V/f Control with PG. When the terminal is reopened, the drive resumes using PG feedback to control motor speed.

**Setting E: ASR Integral Reset**

Switches between PI control and P control by resetting the integral value. Integral operation is disabled when the terminal is closed and the drive uses P control. PI control resumes when the terminal opens.

**Setting F: Through Mode**

Select this setting when using the terminal in a pass-through mode. When set to F, an input does not trigger any function in the drive. Setting F, however, still allows the input status to be read out by a PLC via a communication option or MEMOBUS/Modbus communications.

**Setting 10, 11: Up/Down Function**

The Up/Down function allows the frequency reference to be set by two push buttons when one digital input is programmed as the Up input (H1-□□= 10) to increase the frequency reference and the other digital input is programmed as the Down input (H1-□□= 11) to decrease the frequency reference.

The Up/Down function takes priority over the frequency references from the digital operator, the analog inputs, and the pulse input (b1-01 = 0, 1, 4). When using the Up/Down function, references provided by these sources will be disregarded.

The inputs operate as shown in the table below:

Status		Drive Operation
Up (10)	Down (11)	
Open	Open	Hold current frequency reference
Closed	Open	Increase frequency reference
Open	Closed	Decrease frequency reference
Closed	Closed	Hold current frequency reference

- Note:**
1. An oPE03 alarm occurs when only one of the Up/Down functions is programmed to a digital input.
  2. An oPE03 alarm occurs when the Up/Down function is assigned to the terminals and a different digital input is programmed for the Accel/decel ramp hold function.
  3. The Up/Down function can only be used for External reference 1. Consider this when using Up/Down and the external reference switching command (H1-□□ = 2).

**Using the Up/Down Function with Frequency Reference Hold (d4-01)**

- If the frequency reference hold function is disabled (d4-01 = 0), the Up/Down frequency reference will be reset to 0 when the Run command is cleared or the power is cycled.
- When d4-01 = 1, the drive will save the frequency reference set by the Up/Down function. When the Run command or the power is cycled, the drive will restart with the saved reference value. Close the Up or Down input without an active Run command to reset the saved value. *Refer to d4-01: Frequency Reference Hold Function Selection on page 63.*

**Using the Up/Down Function with Frequency Reference Limits**

Parameter d2-01 determines the upper frequency reference limit.

The value for the lower frequency reference limit depends on the parameter d4-10 setting. This value can be set by an analog input or parameter d2-02. *Refer to d4-10: Up/Down Frequency Reference Limit Selection on page 67* for details. When a Run command is applied, the lower limits function as follows:

- If the lower limit is set by d2-02 only, the drive accelerates to this limit as soon as a Run command is entered.
- If the lower limit is determined by an analog input only, the drive accelerates to the limit when both the Run command and an Up or Down command are active. The drive will not start running if only the Run command is active.
- If the lower limit is set by both an analog input and d2-02, and the analog limit is higher than the d2-02 value, the drive accelerates to the d2-02 value when a Run command is input. When the d2-02 value is reached, the drive accelerates to the analog limit only if an Up or Down command is set.

*Figure 1.56* shows an Up/Down function example with a lower frequency reference limit set by d2-02, and the frequency reference hold function both enabled and disabled.

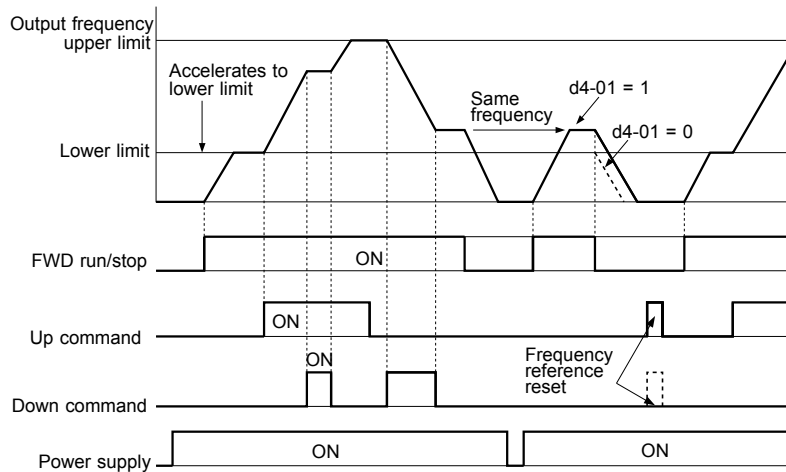
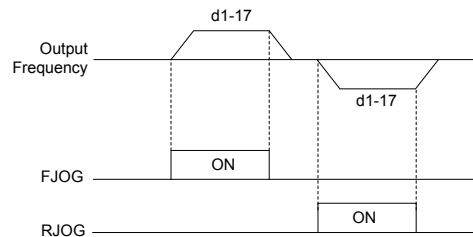

**Figure 1.56 Up/Down Command Operation**

### Setting 12, 13: Forward Jog, Reverse Jog

Digital inputs programmed as Forward Jog (H1-□□ = 12) and Reverse Jog (H1-□□ = 13) will be Jog inputs that do not require a Run command. Closing the terminal set for Forward Jog input will cause the drive to ramp to the Jog frequency reference (d1-17) in the forward direction. The Reverse Jog will cause the same action in the reverse direction. The Forward Jog and Reverse Jog command can be set independently.

**Note:** The Forward Jog and Reverse Jog commands override all other frequency references. However, if the drive is set to prohibit reverse rotation (b1-04 = 1), activating Reverse Jog will have no effect. Inputting both the Forward Jog and Reverse Jog are simultaneously for 500 ms or longer will trigger an alarm and the drive will ramp to stop.



**Figure 1.57 FJOG/RJOG Operation**

### Setting 14: Fault Reset

When the drive detects a fault condition, the fault output contact closes, the drive output shuts off, and the motor coasts to stop (specific stopping methods can be selected for some faults such as L1-04 for motor overheating). After removing the Run command, clear the fault either by pressing the RESET key on the digital operator or closing a digital input configured as a Fault Reset (H1-□□ = 14).

**Note:** Remove the Run command prior to resetting a fault. Fault Reset commands are ignored while the Run command is present.

### Setting 15, 17: Fast Stop (N.O., N.C.)

The Fast Stop function operates similar to an emergency stop input to the drive. If a Fast Stop command is input while the drive is running, the drive decelerates to a stop in the deceleration time set to C1-09 ([Refer to C1-09: Fast Stop Time on page 47](#)). The drive can only be restarted after bringing the drive to a complete stop, turning off the Fast Stop input, and switching off the Run command.

- To trigger the Fast Stop function with an N.O. switch, set H1-□□ = 15.
- To trigger the Fast Stop function with an N.C. switch, set H1-□□ = 17.

[Figure 1.58](#) shows an operation example of Fast Stop.

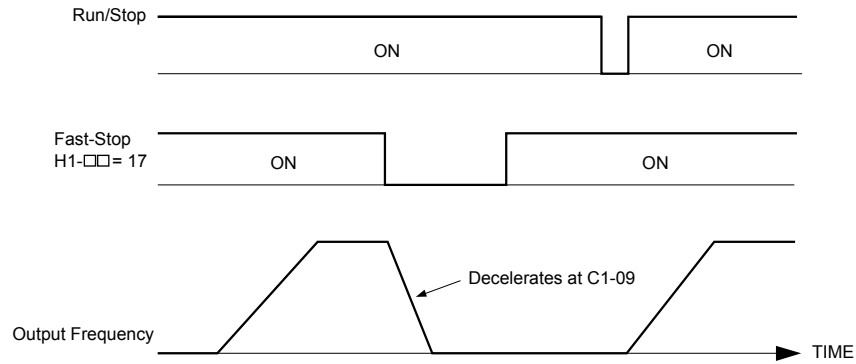

Figure 1.58 Fast Stop Sequence

**NOTICE:** Rapid deceleration can trigger an overvoltage fault. When faulted, the drive output shuts off, and the motor coasts. To avoid this uncontrolled motor state and to ensure that the motor stops quickly and safely, set an appropriate Fast Stop time to C1-09.

**Setting 16: Motor 2 Selection**

The drive has the capability to control two induction motors independently. A second motor may be selected using a multi-function digital input as shown in [Figure 1.59](#).

**Note:** The motor 2 selection function cannot be used with PM motors.

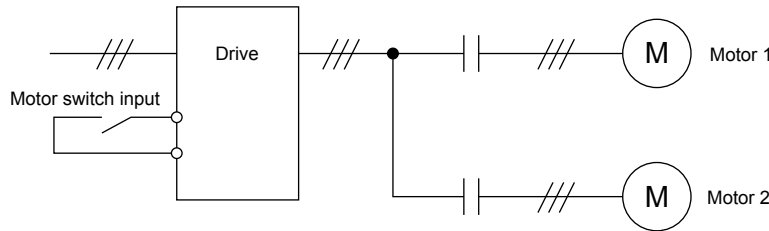

Figure 1.59 Motor Selection

When switching between motor 1 and motor 2, the parameters used to control those motors also change. Below, [Table 1.37](#) lists the parameters that correspond to each motor:

Table 1.37 Parameters for Switching Between Two Motors

No.	Setting 16 Open (Motor 1)	⇒	Setting 16 Closed (Motor 2)
C1-□□: Acceleration/Deceleration Time	C1-01 to C1-04	⇒	C1-05 to C1-08
C3-□□ : Motor Slip Compensation	C3-01 to C3-04, C3-15	⇒	C3-21 to C3-25
C4-□□: Motor Torque Compensation	C4-01	⇒	C4-07
C5-□□: Speed Control (ASR)	C5-01 to C5-08, C5-12, C5-15, C5-17, C5-18	⇒	C5-21 to C5-28, C5-32, C5-35, C5-37, C5-38
E1-□□, E3-□□: V/f Pattern E2-□□, E4-□□: Motor Parameters	E1-□□, E2-□□	⇒	E3-□□ to E4-□□
F1-□□ (PG Constant)	F1-01 to F1-21	⇒	F1-02 to F1-04, F1-08 to F1-11, F1-14, F1-31 to F1-37

- Note:**
1. When using 2 motors, the motor overload protection selection (oL1) set to L1-01 applies to both motor 1 and motor 2.
  2. Attempting to switch between motor 1 and motor 2 during run will trigger the rUn alarm.
  3. There is a 500 ms delay when switching between motors equipped with a PG encoder for feedback.
  4. The motor 2 selection function cannot be used with PM motors.

If a digital output is programmed for “Motor 2 selection” (H1-01, H1-02, or H1-03 = 1C), the motor will be selected when the output is closed.

**Setting 18: Timer Function Input**

This setting configures a digital input terminal as the input for the timer function. Use this setting combination with the timer function output (H2-□□ = 12). [Refer to b4: Delay Timers on page 32](#) for details.

## 1.7 H: Terminal Functions

### Setting 19: PID Disable

Close a digital input to indefinitely disable the PID function. When the input is released, the drive resumes PID operation. *Refer to PID Block Diagram on page 35.*

### Setting 1A: Accel/Decel Time Selection 2

Selects accel/decel times 1 to 4 in combination with the Accel/decel time selection 1 command. *Refer to C1-01 to C1-08: Accel, Decel Times 1 to 4 on page 46* for details.

### Setting 1B: Program Lockout

Parameter values cannot be changed when an input is programmed for Program Lockout and the input is open. It is still possible, however, to view and monitor parameter settings.

### Setting 1E: Reference Sample Hold

This function allows the user to sample an analog frequency reference signal being input to terminal A1, A2, or A3 and hold the frequency reference at the sampled level. When the Analog Frequency Reference Sample/Hold function is held for at least 100 ms, the drive reads the analog input and changes the frequency reference to the newly sampled speed as illustrated in *Figure 1.60*.

When the power is shut off and the sampled analog frequency reference is cleared, the frequency reference is reset to 0.

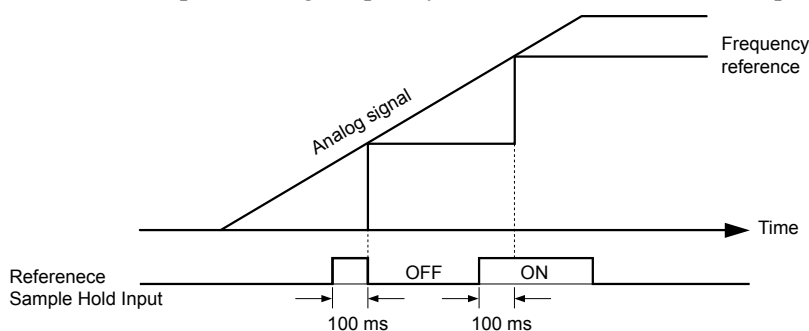

**Figure 1.60** Analog Frequency Reference Sample/Hold

An oPE03 error will occur when one of the following functions is used simultaneously with the Analog frequency reference sample/hold command:

- Hold accel/decel stop (setting: A)
- Up command, Down command (setting: 10, 11)
- Offset frequency (setting: 44 to 46)
- Up or Down functions (setting: 75, 76)

### Setting 20 to 2F: External Fault

The External fault command stops the drive when problems occur with external devices.

To use the External fault command, set one of the multi-function digital inputs to a value between 20 and 2F. The digital operator will display EF□ where □ is the number of the terminal to which the external fault signal is assigned.

For example, if an external fault signal is input to terminal S3, “EF3” will be displayed.

Select the value to be set in H1-□□ from a combination of any of the following three conditions:

- Signal input level from peripheral devices (N.O., N.C.)
- External fault detection method
- Operation after external fault detection

The following table shows the relationship between the conditions and the value set to H1-□□:

Terminal statuses, detection conditions, and stopping methods marked with an “O” are applicable to the corresponding settings.

Setting	Terminal Status <1>		Detection Conditions <2>		Stopping Method			
	N.O.	N.C.	Always Detected	Detected during Run only	Ramp to Stop (fault)	Coast to Stop (fault)	Fast Stop (fault)	Alarm Only (continue running)
20	O		O		O			
21		O	O		O			

Setting	Terminal Status <1>		Detection Conditions <2>		Stopping Method			
	N.O.	N.C.	Always Detected	Detected during Run only	Ramp to Stop (fault)	Coast to Stop (fault)	Fast Stop (fault)	Alarm Only (continue running)
22	O			O	O			
23		O		O	O			
24	O		O			O		
25		O	O			O		
26	O			O		O		
27		O		O		O		
28	O		O				O	
29		O	O				O	
2A	O			O			O	
2B		O		O			O	
2C	O		O					O
2D		O	O					O
2E	O			O				O
2F		O		O				O

<1> Determine the terminal status for each fault, i.e., whether the terminal is normally open or normally closed.

<2> Determine whether detection for each fault should be enabled only during run or always detected.

**Setting 30: PID Integral Reset**

Configuring one of the digital inputs for PID integral reset (H1-□□ = 30) resets the value of the integral component in PID control to 0 when the terminal is closed. [Refer to PID Block Diagram on page 35](#) for more details.

**Setting 31: PID Integral Hold**

Configuring a digital input for Integral Hold (H1-0□ = 31) locks the value of the integral component of the PID control as long as the input is active. The PID controller resumes integral operation from the hold value as soon as the integral hold input is released. [Refer to PID Block Diagram on page 35](#) for more information on this function.

**Setting 32: Multi-Step Speed Reference 4**

Selects the multi-step speeds d1-09 to d1-16 in combination with the input terminal set for Multi-Step Speed 1, 2 and 3. [Refer to d1-01 to d1-17: Frequency Reference 1 to 16 and Jog Frequency Reference on page 59.](#)

**Setting 34: PID Soft Starter Cancel**

A digital input configured as a PID soft starter cancel input (H1-0□ = 34) enables or disables the PID soft starter and cancels the PID accel/decel time (b5-17). [Refer to PID Block Diagram on page 35.](#)

**Setting 35: PID Input Level Selection**

Allows an input terminal to switch the sign of the PID input. [Refer to PID Block Diagram on page 35](#) for details.

**Setting 40, 41: Forward Run, Reverse Run Command for 2-Wire Sequence**

Configures the drive for a 2-Wire sequence.

When an input terminal set to 40 closes, the drive operates in the forward direction. When an input set for 41 closes, the drive operates in reverse. Closing both inputs simultaneously will result in an external fault.

- Note:**
1. This function cannot be used simultaneously with settings 42 and 43.
  2. The same functions are assigned to terminals S1 and S2 when the drive is initialized for 2-Wire sequence.

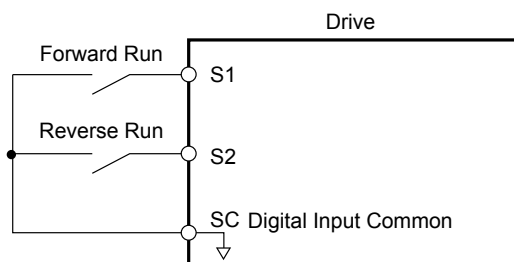

Figure 1.61 Example Wiring Diagram for 2-Wire Sequence

## 1.7 H: Terminal Functions

### Setting 42, 43: Run and Direction Command for 2-Wire Sequence 2

Sets the drive for 2-Wire sequence 2.

When an input terminal programmed for 42 closes, the drive will operate in the selected direction. The drive will stop when the input opens.

The input programmed for 43 selects the direction. If the input is open, forward direction is selected. If the input is closed, reverse direction is selected.

**Note:** This function cannot be used simultaneously with settings 40 and 41.

### Setting 44, 45, 46: Offset Frequency 1, 2, 3

These inputs add offset frequencies d7-01, d7-02, and d7-03 to the frequency reference. [Refer to d7-01 to d7-03: Offset Frequency 1 to 3 on page 73](#) for details.

### Setting 47: Node Setup

If the S1-S3 option card is connected, closing this terminal sets a node address for operation on a CANopen network.

### Setting 60: DC Injection Braking Command

DC Injection Braking is activated when a DC Injection Braking command is input while the drive is stopped. DC Injection Braking is released when a Run command or a Jog command is input. [Refer to b2: DC Injection Braking and Short Circuit Braking on page 25](#) for details on setting up the DC Injection Braking function.

The diagram below illustrates DC Injection Braking:

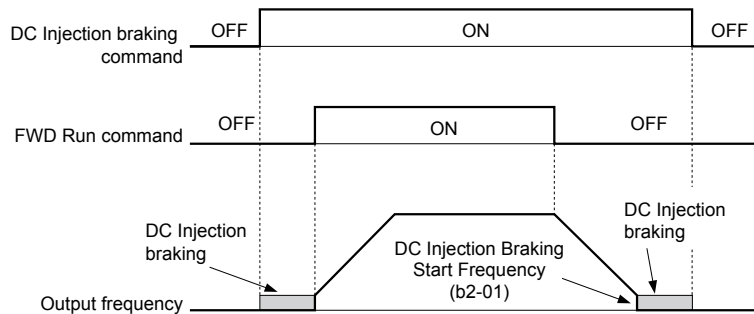

Figure 1.62 DC Injection Braking Input Timing Diagram

### Setting 61, 62: External Speed Search Command 1, 2

These input functions enable Speed Search even if parameter b3-01 = 0 (no Speed Search at start). [Refer to Speed Search Activation on page 30](#) for details on how to use the input signals. [Refer to b3: Speed Search on page 27](#) for more about Speed Search.

**Note:** Simultaneously assigning Speed Search 1 and Speed Search 2 to the input terminals will trigger an oPE03 error.

### Setting 63: Field Weakening

Enabled in V/f Control. When this input is closed, Field Weakening is performed. For details, see [d6: Field Weakening and Field Forcing](#).

### Setting 65, 66: KEB Ride-Thru 1 (N.C.), 2 (N.O.)

Enables the KEB Ride-Thru function selected in parameter L2-29. [Refer to KEB Ride-Thru Function on page 133](#) for more information on this function.

Digital Input Function	Drive Operation	
	Input Open	Input Closed
Setting 65 (N.C.)	KEB Ride-Thru Deceleration	Normal operation
Setting 66 (N.O.)	Normal operation	KEB Ride-Thru Deceleration

**Note:** Simultaneously assigning KEB Ride-Thru 1 and KEB Ride-Thru 2 to the input terminals will trigger an oPE03 error.

### Setting 67: Communication Test Mode

The drive has a built-in function to self-diagnose serial communications operation. The test involves wiring the send and receive terminals of the RS-485/422 port together. The drive transmits data and then confirms that the communications are received normally.

**Setting 6A: Drive Enable**

A digital input configured as a “Drive enable” (H1-□□ = 6A) will prevent the drive from executing a Run command until the input is closed. When the input is open, the digital operator will display “dnE” to indicate that the drive is disabled.

If a Run command is enabled before the terminal set for “Drive enable” closes, then the drive will not run until the Run command is cycled (i.e., a new Run command is required). If the input is opened while the drive is running, the drive will stop according to the stop method set to b1-03 (*Refer to b1-03: Stopping Method Selection on page 20*).

**Setting 71: Speed/Torque Control Switch**

Switches the drive between Torque Control and Speed Control. Torque Control is enabled when the terminal is closed, and Speed Control is enabled when the terminal is open. Set parameter d5-01 to 0 when using this function. *Refer to d5: Torque Control on page 67* and *Switching Between Torque and Speed Control on page 70*.

**Setting 72: Zero Servo**

Activates the Zero Servo function to lock the rotor at a certain position. *Refer to b9: Zero Servo on page 44* for details.

**Setting 75, 76: Up 2/Down 2 Function**

The Up/Down 2 function adds a bias to the frequency reference. The input programmed for 75 will increase the bias and the input programmed for 76 will decrease the bias. *Table 1.38* explains how the Up/Down 2 function works depending on the frequency reference source and parameters d4-01, d5-03, and d4-05. *Refer to d4: Frequency Reference Hold and Up/Down 2 Function on page 63* for detailed explanations of these and other Up/Down 2 related parameters.

- Note:**
1. The Up/Down 2 functions must be set as a pair.
  2. When using the Up/Down 2 function, set appropriate bias limit values to parameters d4-08 and d4-09.

**Table 1.38 Up/Down 2 Operations**

Condition	Freq. Ref. Source	d4-03	d4-05	d4-01	Operation	Frequency Saved
1	Multi-Step Speed Reference	0	0	0	<ul style="list-style-type: none"> <li>• Accelerates (increases the bias) while the Up 2 terminal is closed.</li> </ul>	Not saved
2				1	<ul style="list-style-type: none"> <li>• Decelerates (decreases the bias) while Down 2 is closed.</li> <li>• Holds output frequency (holds the bias) when no Up 2 or Down 2 input or both active.</li> <li>• Resets the bias when the reference changes.</li> <li>• Operates with the frequency reference in all other situations.</li> </ul>	If the bias and frequency reference are constant for 5 s, the bias is added to the active frequency reference and reset afterwards.
3				--	<ul style="list-style-type: none"> <li>• Accelerates (increases the bias) while the Up 2 terminal is closed.</li> <li>• Decelerates (decreases the bias) while Down 2 is closed.</li> <li>• Otherwise operates at the frequency reference.</li> </ul>	Not saved
4	Multi-Step Speed Reference	Value other than 0	--	0	<ul style="list-style-type: none"> <li>• When the Up 2 is enabled, the drive accelerates to the frequency reference plus d4-03 (bias is increased for d4-03).</li> <li>• When Down 2 is enabled, the drive decelerates to the frequency reference minus d4-03 (bias is decreased for d4-03).</li> </ul>	Not saved
5				1	<ul style="list-style-type: none"> <li>• Holds output frequency (holds the bias) when neither Up/Down 2 inputs are active or both inputs are active.</li> <li>• Resets the bias when the reference changes.</li> <li>• Operates with the frequency reference in all other situations.</li> </ul>	If the bias and frequency reference are constant for 5 s, the bias is added to the active frequency reference and reset afterwards.
6	Other (analog comm., etc.)	0	0	0	<ul style="list-style-type: none"> <li>• Accelerates (increases the bias) while the Up 2 terminal is closed.</li> <li>• Decelerates (decreases the bias) while Down 2 is closed.</li> </ul>	Not saved
7				1	<ul style="list-style-type: none"> <li>• Holds output frequency (holds the bias) when neither Up/Down 2 inputs are active or both inputs are active.</li> <li>• If the frequency reference changes for more than the time set to d4-07 during accel/decel, bias value is held until the output frequency meets the reference (speed agree).</li> </ul>	If the bias is constant for 5 s, it is saved to parameter d4-06. The frequency reference cannot be overwritten, so only the bias is saved.

## 1.7 H: Terminal Functions

Condition	Freq. Ref. Source	d4-03	d4-05	d4-01	Operation	Frequency Saved
8	Other (analog comm, etc.)	0	1	--	<ul style="list-style-type: none"> <li>Accelerates (increases the bias) while the Up 2 terminal is closed.</li> <li>Decelerates (decreases the bias) while Down 2 is closed.</li> <li>Otherwise operates at the frequency reference</li> </ul>	Not saved
9		Value other than 0	--	0	<ul style="list-style-type: none"> <li>When Up 2 is enabled, drive accelerates to the frequency reference plus d4-03 (increases the bias for d4-03).</li> </ul>	Not saved
10				1	<ul style="list-style-type: none"> <li>When Down 2 is enabled, drive decelerates to the frequency reference minus d4-03 (decreases the bias for d4-03).</li> <li>If the frequency reference changes for more than d4-07 during accel/decel, bias value is held until the output frequency meets the reference (speed agree).</li> </ul>	If the bias is constant for 5 s, it is saved to parameter d4-06. The frequency reference cannot be overwritten, so only the bias is saved.

### Setting 77: ASR Gain Switch

Switches the ASR gain between the values set to C5-01 and C5-03. The gain set to C5-03 is enabled when the terminal is closed, and C5-01 is enabled when the terminal reopens. [Refer to C5-01, C5-03/C5-02, C5-04: ASR Proportional Gain 1, 2/ ASR Integral Time 1, 2 on page 54](#) for a more detailed description.

### Setting 78: External Torque Reference Polarity Inversion

Reverses the direction of the torque reference when the terminal closes. [Refer to d5: Torque Control on page 67](#) and [Setting the Torque Reference, Speed Limit, and Torque Compensation Values on page 68](#) for details.

### Setting 7E: Forward/Reverse Detection (for V/f Control with Simple PG Feedback)

Determines the motor rotation direction for V/f Control with Simple PG feedback (A1-02 = 0 and H6-01 = 3). If the input is open, the speed feedback signal is considered to be forward. If the input is closed, it is considered to be reverse. [Refer to H6: Pulse Train Input/Output on page 123](#).

### Setting 90 to 97: DriveWorksEZ Digital Input 1 to 8

These settings are for digital input functions used in DriveWorksEZ. Changing these settings is not typically required.

### Setting 9F: DriveWorksEZ Disable

This function is used to enable or disable a DriveWorksEZ program in the drive. An input programmed for this function is effective only if A1-07 = 2.

Status	Description
Open	DriveWorksEZ enabled
Closed	DriveWorksEZ disabled

## ◆ H2: Multi-Function Digital Outputs

### ■ H2-01 to H2-03: Terminal M1-M2, M3-M4, and M5-M6 Function Selection

The drive has three multi-function output terminals. [Table 1.39](#) lists the functions available for these terminals using H2-01, H2-02, and H2-03.

No.	Parameter Name	Setting Range	Default
H2-01	Terminal M1-M2 Function Selection (relay)	0 to 192	0: During run
H2-02	Terminal M3-M4 Function Selection (relay)	0 to 192	1: Zero Speed
H2-03	Terminal M5-M6 Function Selection (relay)	0 to 192	2: Speed agree 1

Table 1.39 Multi-Function Digital Output Terminal Settings

Setting	Function	Page	Setting	Function	Page
0	During Run	<a href="#">105</a>	6	Drive Ready	<a href="#">107</a>
1	Zero Speed	<a href="#">105</a>	7	DC Bus Undervoltage	<a href="#">108</a>
2	Speed Agree 1	<a href="#">106</a>	8	During Baseblock (N.O.)	<a href="#">108</a>
3	User-Set Speed Agree 1	<a href="#">106</a>	9	Frequency Reference Source	<a href="#">108</a>
4	Frequency Detection 1	<a href="#">107</a>	A	Run Command Source	<a href="#">108</a>
5	Frequency Detection 2	<a href="#">107</a>	B	Torque Detection 1 (N.O.)	<a href="#">108</a>



Setting	Function	Page
C	Frequency Reference Loss	108
E	Fault	108
F	Through Mode	108
10	Minor Fault	109
11	Fault Reset Command Active	109
12	Timer Output	109
13	Speed Agree 2	109
14	User-Set Speed Agree 2	109
15	Frequency Detection 3	110
16	Frequency Detection 4	110
17	Torque Detection 1 (N.C.)	108
18	Torque Detection 2 (N.O.)	
19	Torque Detection 2 (N.C.)	108
1A	During Reverse	111
1B	During Baseblock (N.C.)	111
1C	Motor 2 Selection	111
1D	During regeneration	111
1E	Restart Enabled	111
1F	Motor Overload Alarm (oL1)	112
20	Drive Overheat Pre-Alarm (oH)	112
22	Mechanical Weakening Detection	112

Setting	Function	Page
2F	Maintenance Period	112
30	During Torque Limit	112
31	During Speed Limit	112
32	During Speed Limit in Torque Control	112
33	Zero Servo Complete	112
37	During Frequency Output	112
38	Drive Enabled	113
39	Watt Hour Pulse Output	113
3C	LOCAL/REMOTE Status	113
3D	During Speed Search	113
3E	PID Feedback Low	113
3F	PID Feedback High	113
4A	During KEB Operation	113
4C	During Fast Stop	113
4D	oH Pre-Alarm Time Limit	113
60	Internal Cooling Fan Alarm	113
90	DriveWorksEZ Digital Output 1	113
91	DriveWorksEZ Digital Output 2	
92	DriveWorksEZ Digital Output 3	
100 to 192	Functions 0 to 92 with Inverse Output	113

**Setting 0: During Run**

Output closes when the drive is outputting a voltage.

Status	Description
Open	Drive is stopped.
Closed	A Run command is input or the drive is in deceleration or DC injection.

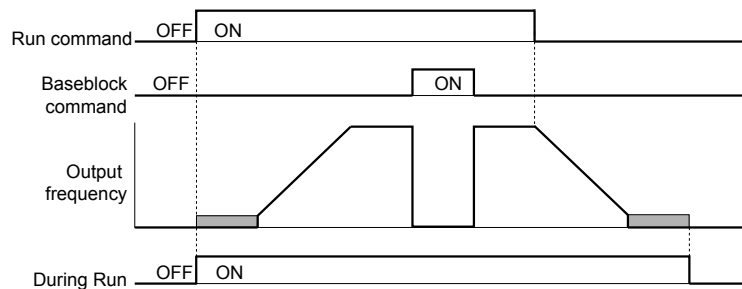

Figure 1.63 During Run Time Chart

**Setting 1: Zero Speed**

Terminal closes when the output frequency or motor speed (CLV, CLV/PM) falls below the minimum output frequency set to E1-09 or b2-01.

Status	Description
Open	Output frequency is above the minimum output frequency set to E1-09 or b2-01
Closed	Output frequency is less than the minimum output frequency set to E1-09 or b2-01

**Note:** In CLV and CLV/PM control modes, the zero speed level is defined by b2-01. In all other control modes, the zero speed level is the minimum output frequency set to E1-09.

## 1.7 H: Terminal Functions

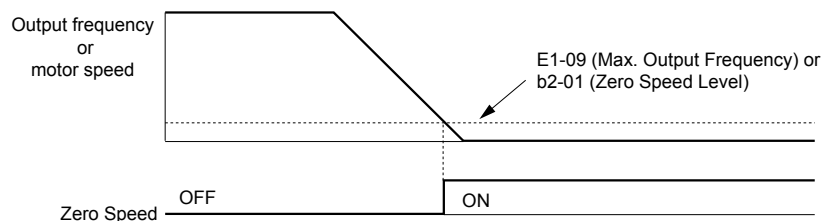

Figure 1.64 Zero-Speed Time Chart

### Setting 2: Speed Agree 1 ( $f_{ref}/f_{out}$ Agree 1)

Closes when the actual output frequency or motor speed (CLV, CLV/PM) is within the Speed Agree Width (L4-02) of the current frequency reference regardless of the direction.

Status	Description
Open	Output frequency or motor speed does not match the frequency reference while the drive is running.
Closed	Output frequency or motor speed is within the range of frequency reference $\pm L4-02$ .

**Note:** Detection works in forward and reverse.

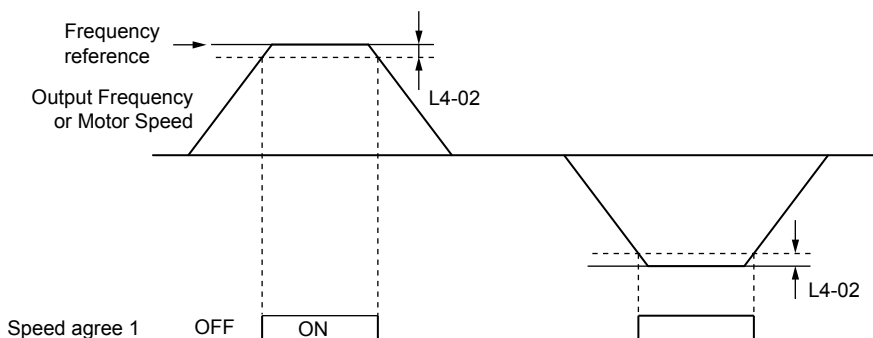

Figure 1.65 Speed Agree 1 Time Chart

*Refer to L4-01, L4-02: Speed Agreement Detection Level and Detection Width on page 143 for more details.*

### Setting 3: User-Set Speed Agree 1 ( $f_{ref}/f_{set}$ Agree 1)

Closes when the actual output frequency or motor speed (CLV, CLV/PM) and the frequency reference are within the speed agree width (L4-02) of the programmed speed agree level (L4-01).

Status	Description
Open	Output frequency or motor speed and frequency reference are not both within the range of $L4-01 \pm L4-02$ .
Closed	Output frequency or motor speed and the frequency reference are both within the range of $L4-01 \pm L4-02$ .

**Note:** Frequency detection works in forward and reverse. The value of L4-01 is used as the detection level for both directions.

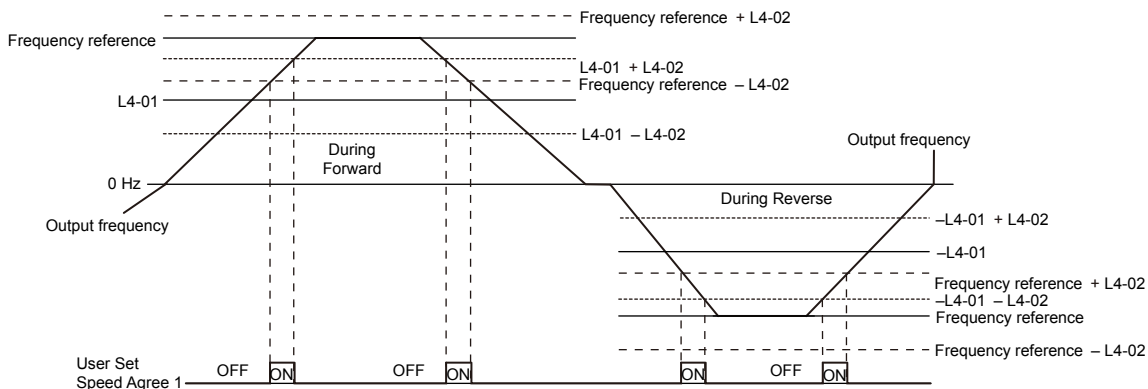

Figure 1.66 User Set Speed Agree 1 Time Chart

Refer to L4-01, L4-02: Speed Agreement Detection Level and Detection Width on page 143 for more instructions.

**Setting 4: Frequency Detection 1**

The output opens when the output frequency or motor speed (CLV, CLV/PM) rises above the detection level set in L4-01 plus the detection width set in L4-02. The terminal remains open until the output frequency or motor speed fall below the level set in L4-01.

Status	Description
Open	Output frequency or motor speed exceeded L4-01 + L4-02.
Closed	Output frequency or motor speed is below L4-01 or has not exceeded L4-01 + L4-02.

**Note:** Frequency detection works in forward and reverse. The value of L4-01 is used as the detection level for both directions.

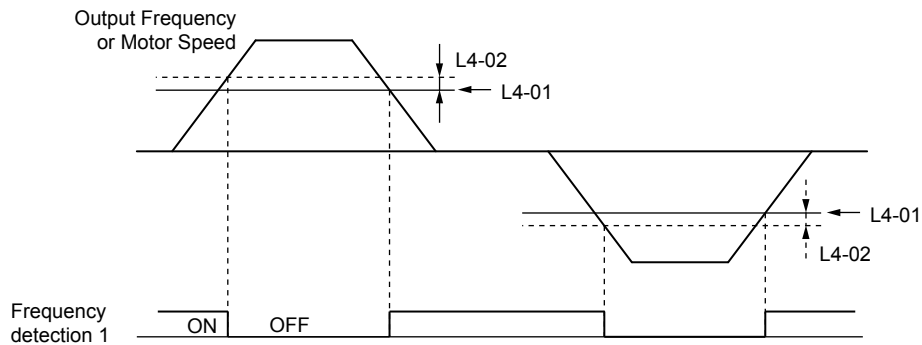

Figure 1.67 Frequency Detection 1 Time Chart

Refer to L4-01, L4-02: Speed Agreement Detection Level and Detection Width on page 143 for more details.

**Setting 5: Frequency Detection 2**

The output closes when the output frequency or motor speed (CLV, CLV/PM) is above the detection level set in L4-01. The terminal remains closed until the output frequency or motor speed fall below L4-01 minus the setting of L4-02.

Status	Description
Open	Output frequency or motor speed is below L4-01 minus L4-02 or has not exceeded L4-01.
Closed	Output frequency or motor speed exceeded L4-01.

**Note:** Frequency detection works in forward and reverse. The value of L4-01 is used as the detection level for both directions.

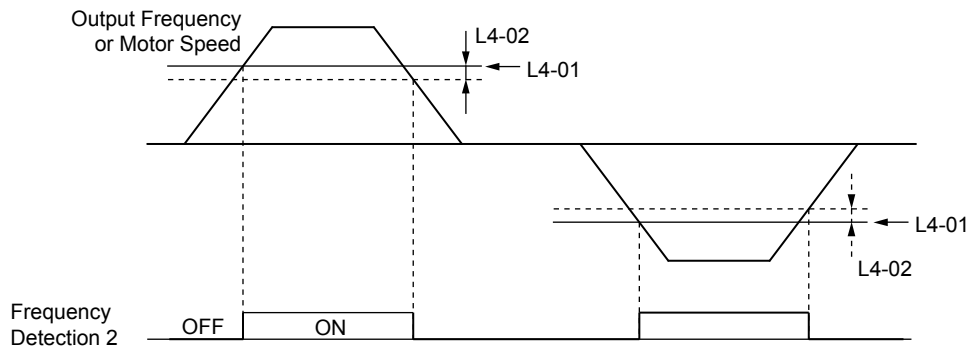

Figure 1.68 Frequency Detection 2 Time Chart

Refer to L4-01, L4-02: Speed Agreement Detection Level and Detection Width on page 143 for more details.

**Setting 6: Drive Ready**

The output closes when the drive is ready to operate the motor. The terminal will not close under the conditions listed below, and any Run commands will be disregarded.

- When the power is shut off
- During a fault
- When the internal power supply of the drive has malfunctioned
- When a parameter setting error makes it impossible to run

## 1.7 H: Terminal Functions

- Although stopped, an overvoltage or undervoltage situation occurs
- While editing a parameter in the Programming Mode (when b1-08 = 0)

### Setting 7: DC Bus Undervoltage

The output closes when the DC bus voltage or control circuit power supply drops below the trip level set in L2-05. A fault in the DC bus circuit will also cause the terminal set for “DC bus undervoltage” to close.

Status	Description
Open	DC bus voltage is above the level set to L2-05.
Closed	DC bus voltage has fallen below the trip level set to L2-05.

### Setting 8: During Baseblock (N.O.)

The output closes to indicate that the drive is in a baseblock state. While in baseblock, output transistors do not switch and no main circuit voltage is output.

Status	Description
Open	Drive is not in a baseblock state.
Closed	Baseblock is being executed.

### Setting 9: Frequency Reference Source

Displays the currently selected frequency reference source.

Status	Description
Open	Frequency reference is provided from External reference 1 (b1-01) or External reference 2 (b1-15).
Closed	Frequency reference is being sourced from the digital operator.

### Setting A: Run Command Source

Displays the currently selected Run command source.

Status	Description
Open	Run command is provided from External reference 1 (b1-02) or 2 (b1-16).
Closed	Run command is being sourced from the digital operator.

### Setting B, 17, 18, 19: Torque Detection 1 (N.O., N.C.), Torque Detection 2 (N.O., N.C.)

These digital output functions signal an overtorque or undertorque situation to an external device.

Set up the torque detection levels and select the output function from the table below. [Refer to L6: Torque Detection on page 146](#) for details.

Setting	Status	Description
B	Closed	Torque detection 1 (N.O.): Output current/torque exceeds (overtorque detection) or is below (undertorque detection) the torque value set in parameter L6-02 for longer than the time specified in parameter L6-03.
17	Open	Torque detection 1 (N.C.): Output current/torque exceeds (overtorque detection) or is below (undertorque detection) the torque value set in parameter L6-02 for longer than the time specified in parameter L6-03.
18	Closed	Torque detection 2 (N.O.): Output current/torque exceeds (overtorque detection) or is below (undertorque detection) the torque value set in parameter L6-05 for longer than the time specified in parameter L6-06.
19	Open	Torque detection 2 (N.C.): Output current/torque exceeds (overtorque detection) or is below (undertorque detection) the torque value set in parameter L6-05 for longer than the time specified in parameter L6-06.

### Setting C: Frequency Reference Loss

An output set for this function closes when frequency reference loss is detected. [Refer to L4-05: Frequency Reference Loss Detection Selection on page 144](#) for details.

### Setting E: Fault

The output closes when the drive faults (excluding CPF00 and CPF01 faults).

### Setting F: Through Mode

Select this setting when using the terminal in a pass-through mode. When set to F, an output does not trigger any function in the drive. Setting F, however, still allows the output status to be read by a PLC via a communication option or MEMOBUS/Modbus communications.

**Setting 10: Minor Fault**

The output closes when a minor fault condition is present.

**Setting 11: Fault Reset Command Active**

The output closes when there is an attempt to reset a fault situation from the control circuit terminals, via serial communications, or using a communications option card.

**Setting 12: Timer Output**

This setting configures a digital output terminal as the output for the timer function. *Refer to b4: Delay Timers on page 32* for details.

**Setting 13: Speed Agree 2 ( $f_{ref}/f_{out}$  Agree 2)**

The output closes when the actual output frequency or motor speed (CLV, CLV/PM) is within the speed agree width (L4-04) of the current frequency reference, regardless of the direction.

Status	Description
Open	Output frequency or motor speed does not match the frequency reference while the drive is running.
Closed	Output frequency or motor speed is within the range of frequency reference $\pm L4-04$ .

**Note:** Detection works in forward and reverse.

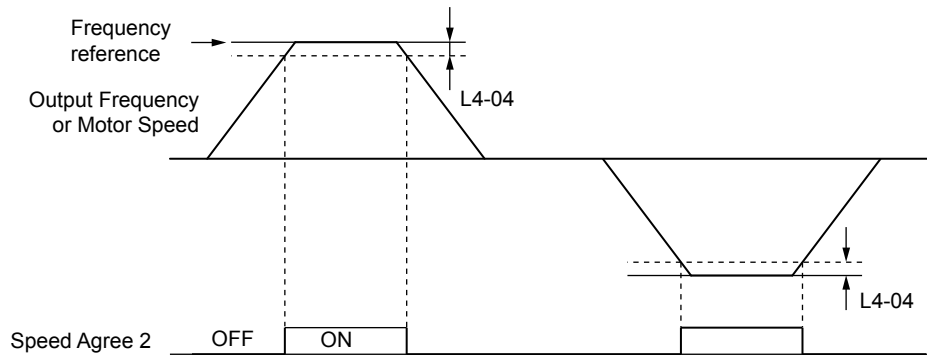

Figure 1.69 Speed Agree 2 Time Chart

*Refer to L4-03, L4-04: Speed Agreement Detection Level and Detection Width (+/-) on page 144* for more details.

**Setting 14: User-Set Speed Agree 2 ( $f_{ref}/f_{set}$  Agree 2)**

The output closes when the actual output frequency or motor speed (CLV, CLV/PM) and the frequency reference are within the speed agree width (L4-04) of the programmed speed agree level (L4-03).

Status	Description
Open	Output frequency or motor speed and frequency reference are both outside the range of $L4-03 \pm L4-04$ .
Closed	Output frequency or motor speed and the frequency reference are both within the range of $L4-03 \pm L4-04$ .

**Note:** The detection level L4-03 is a signed value; detection works in the specified direction only.

## 1.7 H: Terminal Functions

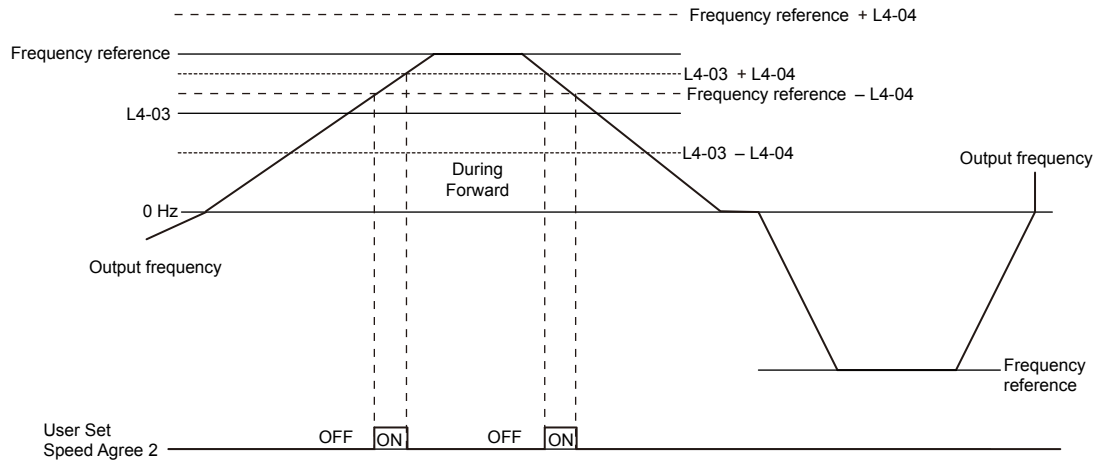

Figure 1.70 User-Set Speed Agree 2 Example with a Positive L3-04 Value

Refer to L4-03, L4-04: Speed Agreement Detection Level and Detection Width (+/-) on page 144 for more details.

### Setting 15: Frequency Detection 3

The output opens when the output frequency or motor speed (CLV, CLV/PM) rises above the detection level set in L4-03 plus the detection width set in L4-04. The terminal remains open until the output frequency or motor speed falls below the level set in L4-03. The detection level L4-03 is a signed value; detection works in the specified direction only.

Status	Description
Open	Output frequency or motor speed exceeded L4-03 plus L4-04.
Closed	Output frequency or motor speed is below L4-03 or has not exceeded L4-03 plus L4-04.

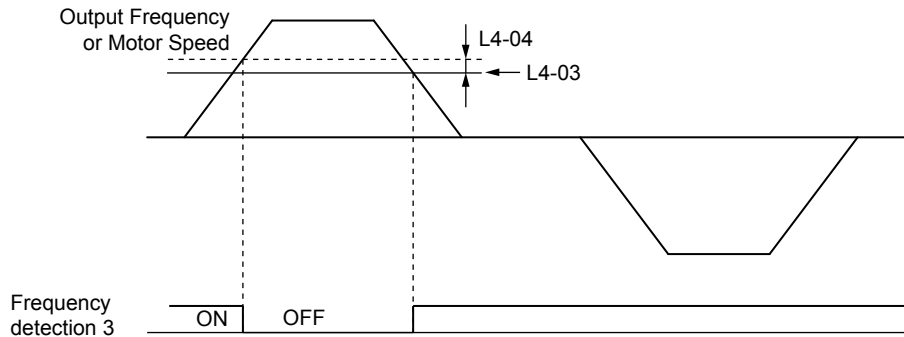

Figure 1.71 Frequency Detection 3 Example with a Positive L3-04 Value

Refer to L4-03, L4-04: Speed Agreement Detection Level and Detection Width (+/-) on page 144 for more details.

### Setting 16: Frequency Detection 4

The output closes when the output frequency or motor speed (CLV, CLV/PM) is above the detection level set in L4-03. The terminal remains closed until the output frequency or motor speed falls below L4-03 minus the setting of L4-04.

Status	Description
Open	Output frequency or motor speed is below L4-03 minus L4-04 or has not exceeded L4-03.
Closed	Output frequency or motor speed exceeded L4-03.

**Note:** The detection level L4-03 is a signed value; detection works in the specified direction only.

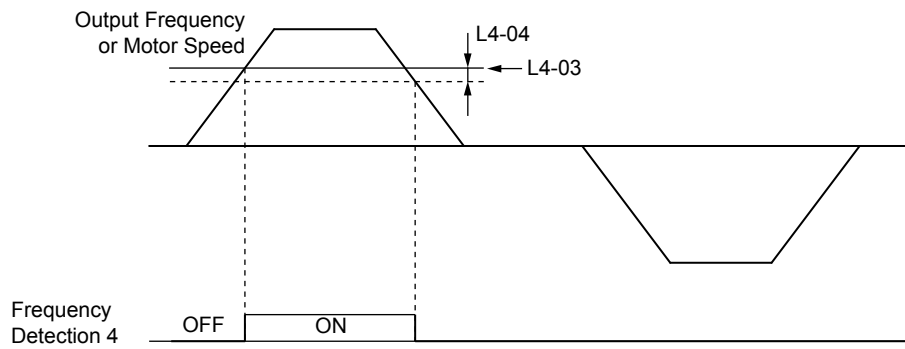

Figure 1.72 Frequency Detection 4 Example with Positive L3-04 Value

Refer to L4-03, L4-04: Speed Agreement Detection Level and Detection Width (+/-) on page 144 for more details.

**Setting 1A: During Reverse**

A digital output set for “During reverse” closes when the drive is running the motor in the reverse direction.

Status	Description
Open	Motor is being driven in the forward direction or stopped.
Closed	Motor is being driven in reverse.

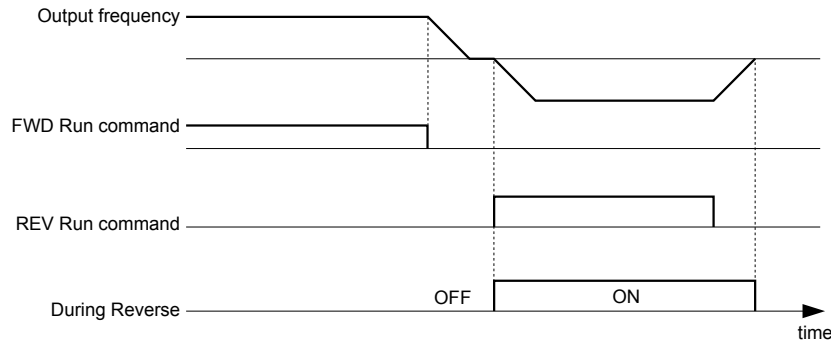

Figure 1.73 Reverse Direction Output Example Time Chart

**Setting 1B: During Baseblock (N.C.)**

The output opens to indicate that the drive is in a baseblock state. While Baseblock is executed, output transistors do not switch and no main circuit voltage is output.

Status	Description
Open	Baseblock is being executed.
Closed	Drive is not in a baseblock state.

**Setting 1C: Motor 2 Selection**

Indicates which motor is selected when another output terminal is set to switch drive operation between two motors (H1-□□ = 16). Refer to Setting 16: Motor 2 Selection on page 99 for details on switching motors.

Status	Description
Open	Motor 1 is selected.
Closed	Motor 2 is selected.

**Setting 1D: During Regeneration**

Terminal closes when the motor is driven in the regenerative mode.

**Setting 1E: Restart Enabled**

An output set for “Restart enabled” closes when the drive attempts to restart after a fault has occurred.

## 1.7 H: Terminal Functions

The fault restart function allows the drive to automatically clear a fault. The terminal set to 1E will close after the fault is cleared and the drive has attempted to restart. If the drive cannot successfully restart within the number of attempts permitted by L5-01, a fault will be triggered and the terminal set to 1E will open. [Refer to L5: Fault Restart on page 145](#) for details on automatic restart.

### Setting 1F: Motor Overload Alarm (oL1)

The output closes when the motor overload level estimated by the oL1 fault detection exceeds 90% of the oL1 detection level. [Refer to L1-01: Motor Overload Protection Selection on page 126](#).

### Setting 20: Drive Overheat Pre-Alarm (oH)

The output closes when the drive heatsink temperature reaches the level specified by parameter L8-02. [Refer to L8-02: Overheat Alarm Level on page 150](#) for details on drive overheat detection.

### Setting 22: Mechanical Weakening Detection

The output closes when a mechanical weakening situation is detected. [Refer to Mechanical Weakening Detection on page 147](#) for details.

### Setting 2F: Maintenance Period

The output closes when the cooling fan, DC bus capacitors, or DC bus pre-charge relay may require maintenance as determined by the estimated performance life span of those components. Components performance life is displayed as a percentage on the digital operator screen.

### Setting 30: During Torque Limit

**Note:** PM motor control modes are not available in A1000 HHP drive models.

The output closes when the motor is operating at the torque limit specified by the L7-□□ parameters or an analog input. This setting can only be used in OLV, CLV, AOLV/PM and CLV/PM control modes. [Refer to L7-01 to L7-04: Torque Limits on page 149](#) for details.

### Setting 31: During Speed Limit

**Note:** PM motor control modes are not available in A1000 HHP drive models.

The output closes when the speed limit has been reached. This function can be used in CLV and CLV/PM control modes.

Status	Description
Open	The conditions described below are not present.
Closed	<ol style="list-style-type: none"><li>1. The frequency reference has reached the upper limit set in d2-01.</li><li>2. The frequency reference has fallen to the lower limit set in d2-02 or d2-03.</li><li>3. Parameter b1-05 is set to 1, 2, or 3, and the frequency reference has fallen below the minimum output frequency (E1-09).</li></ol>

### Setting 32: During Speed Limit in Torque Control

The motor torque and load torque are not in balance, causing the motor to accelerate. The output closes when the motor reaches the speed limit. [Refer to d5: Torque Control on page 67](#) and [Indicating Operation at the Speed Limit on page 70](#) for details.

### Setting 33: Zero Servo Complete

The output closes when Zero Servo is enabled and the load is locked into position within the allowable deviation (b9-02). [Refer to b9: Zero Servo on page 44](#) for information on Zero Servo operation.

### Setting 37: During Frequency Output

The output closes when the drive is outputting a frequency.

Status	Description
Open	Drive is stopped or one of the following functions is being performed: baseblock, DC Injection Braking, Short Circuit Braking.
Closed	Drive is outputting frequency.



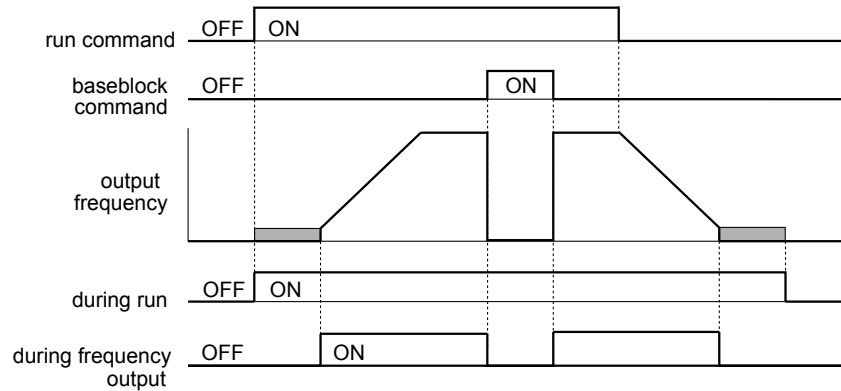

Figure 1.74 During Frequency Output Time Chart

**Setting 38: Drive Enable**

Reflects the status of a digital input configured as a “Drive enable” input (H1-□□ = 6A). If that digital input closes, then the digital output set for “Drive enable” will also close.

**Setting 39: Watt Hour Pulse Output**

Outputs a pulse to indicate the watt hours. *Refer to H2-06: Watt Hour Output Unit Selection on page 114* for details.

**Setting 3C: LOCAL/REMOTE Status**

The output terminal closes while the drive is set for LOCAL and opens when in REMOTE.

Status	Description
Open	REMOTE: The external reference that has been selected (either b1-01 and b1-02 or b1-15 and b1-16) is used as frequency reference and Run command source.
Closed	LOCAL: The digital operator is used as frequency reference and Run command source.

**Setting 3D: During Speed Search**

The output terminal closes while Speed Search is being performed. *Refer to b3: Speed Search on page 27* for details.

**Setting 3E: PID Feedback Low**

The output terminal closes when a PID feedback loss is detected. The feedback is considered to be lost if it falls below the level set to b5-13 for longer than the time set to b5-14. *Refer to PID Feedback Loss Detection on page 37* for details.

**Setting 3F: PID Feedback High**

The output terminal closes when a PID feedback loss is detected. The feedback is considered to be lost if it rises beyond the level set to b5-36 for longer than the time set to b5-37. *Refer to PID Feedback Loss Detection on page 37* for details.

**Setting 4A: During KEB Operation**

The output terminal closes while KEB is being performed. *Refer to KEB Ride-Thru Function on page 133* for a KEB function description.

**Setting 4C: During Fast Stop**

The output terminal closes when a Fast Stop is being executed. *Refer to Setting 15, 17: Fast Stop (N.O., N.C.) on page 98.*

**Setting 4D: oH Pre-Alarm Time Limit**

The output terminal closes when the drive is reducing the speed due to a drive overheat alarm (L8-03 = 4) and the overheat alarm has not disappeared after 10 frequency reduction operation cycles. *Refer to L8-03: Overheat Pre-Alarm Operation Selection on page 150* for a more detailed description.

**Setting 60: Internal Cooling Fan Alarm**

The output closes when the drive internal cooling fan has failed.

**Setting 90 to 92: DriveWorksEZ Digital Output 1 to 3**

These settings are for output functions used in DriveWorksEZ. Normally there is no need to change these settings.

**Setting 100 to 192: Functions 0 to 92 with Inverse Output**

These settings have the same function as settings 0 to 92 but with inverse output. Set as 1□□, where the “1” indicates inverse output and the last two digits specify the setting number of the function.

## 1.7 H: Terminal Functions

Examples:

- For inverse output of “8: During baseblock”, set 108.
- For inverse output of “4A: During KEB” set 14A.

### ■ H2-06: Watt Hour Output Unit Selection

When one of the multi-function terminals is set to output the number of watt hours (H2-01, H2-02, or H2-03 = 39), parameter H2-06 determines the units for the output signal.

This output function provides a watt hour meter or a PLC input by a 200 ms pulse signal. H2-06 determines the frequency that pulses are issued to keep track of the kWh for the drive.

No.	Parameter Name	Setting Range	Default
H2-06	Watt Hour Output Unit Selection	0: 0.1 kWh units 1: 1 kWh units 2: 10 kWh units 3: 100 kWh units 4: 1000 kWh units	0

- Note:**
1. A negative power output (i.e., regeneration) does not subtract from the total watt hours.
  2. The drive keeps track of the watt hours as long as the control circuit has power. The value is reset when the power supply is shut off.

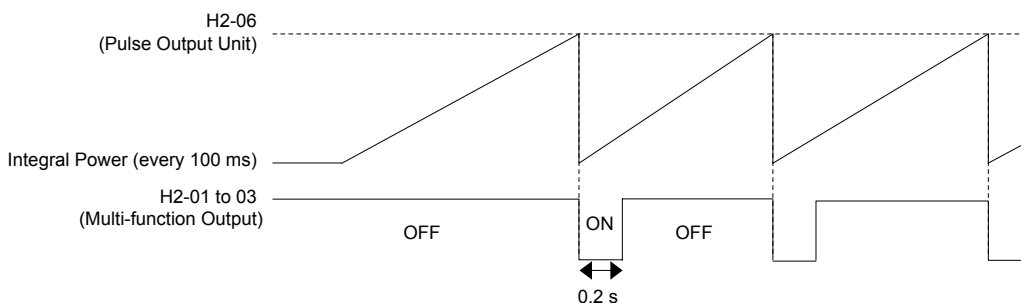

Figure 1.75 Watt Hour Output Example

## ◆ H3: Multi-Function Analog Inputs

The drive is equipped with three multi-function analog input terminals: A1, A2, and A3. [Refer to Multi-Function Analog Input Terminal Settings on page 117](#) for a listing of the functions that can be set to these terminals.

### ■ H3-01: Terminal A1 Signal Level Selection

Selects the input signal level for analog input A1.

No.	Name	Setting Range	Default
H3-01	Terminal A1 Signal Level Selection	0 to 1	0

#### Setting 0: 0 to 10 Vdc

The input level is 0 to 10 Vdc. The minimum input level is limited to 0%, so that a negative input signal due to gain and bias settings will be read as 0%.

#### Setting 1: -10 to 10 Vdc

The input level is -10 to 10 Vdc. If the resulting voltage is negative after being adjusted by gain and bias settings, then the motor will rotate in reverse.

### ■ H3-02: Terminal A1 Function Selection

Selects the input signal level for analog input A3. [Refer to Multi-Function Analog Input Terminal Settings on page 117](#) for instructions on adjusting the signal level.

No.	Name	Setting Range	Default
H3-02	Terminal A1 Function Selection	0 to 31	0

### ■ H3-03, H3-04: Terminal A1 Gain and Bias Settings

Parameter H3-03 sets the level of the selected input value that is equal to 10 Vdc input at terminal A1 (gain).

Parameter H3-04 sets the level of the selected input value that is equal to 0 V input at terminal A1 (bias).

Use both parameters to adjust the characteristics of the analog input signal to terminal A1.

No.	Name	Setting Range	Default
H3-03	Terminal A1 Gain Setting	-999.9 to 999.9%	100.0%
H3-04	Terminal A1 Bias Setting	-999.9 to 999.9%	0.0%

**Setting Examples**

- Gain H3-03 = 200%, bias H3-04 = 0, terminal A1 as frequency reference input (H3-02 = 0):

A 10 Vdc input is equivalent to a 200% frequency reference and 5 Vdc is equivalent to a 100% frequency reference. Since the drive output is limited by the maximum frequency parameter (E1-04), the frequency reference will be equal to E1-04 above 5 Vdc.

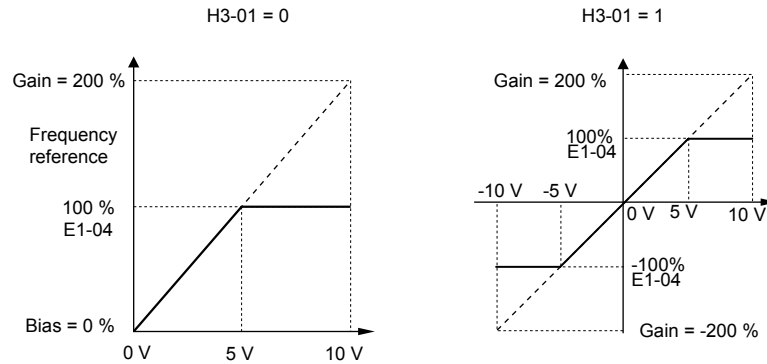

Figure 1.76 Frequency Reference Setting by Analog Input with Increased Gain

- Gain H3-03 = 100%, bias H3-04 = -25%, terminal A1 as frequency reference input:

An input of 0 Vdc will be equivalent to a -25% frequency reference.

When parameter H3-01 = 0, the frequency reference is 0% between 0 and 2 Vdc input.

When parameter H3-01 = 1, the motor will rotate in reverse between -10 and 2 Vdc input.

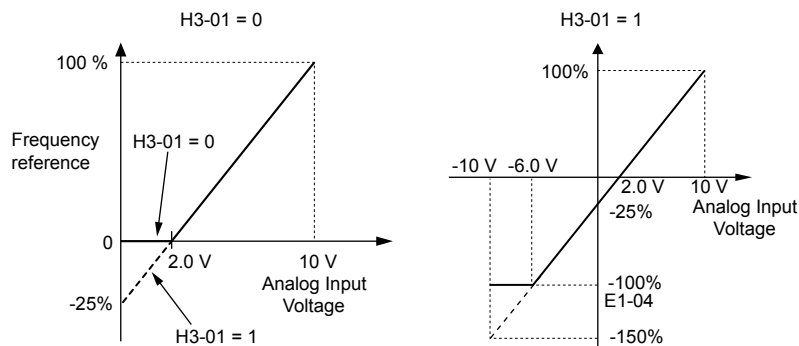

Figure 1.77 Frequency Reference Setting by Analog Input with Negative Bias

**■ H3-05: Terminal A3 Signal Level Selection**

Determines the function assigned to analog input terminal A3. *Refer to Multi-Function Analog Input Terminal Settings on page 117* for a list of functions and descriptions.

No.	Name	Setting Range	Default
H3-05	Terminal A3 Signal Level Selection	0, 1	0

**Setting 0: 0 to 10 Vdc**

The input level is 0 to 10 Vdc. See the explanation provided for H3-01. *Refer to Setting 0: 0 to 10 Vdc on page 114.*

**Setting 1: -10 to 10 Vdc**

The input level is -10 to 10 Vdc. See the explanation provided for H3-01. *Refer to Setting 1: -10 to 10 Vdc on page 114.*

## 1.7 H: Terminal Functions

### ■ H3-06: Terminal A3 Function Selection

Determines the function assigned to analog input terminal A3. [Refer to Multi-Function Analog Input Terminal Settings on page 117](#) for a list of functions and descriptions.

No.	Name	Setting Range	Default
H3-06	Terminal A3 Function Selection	0 to 31	2

### ■ H3-07, H3-08: Terminal A3 Gain and Bias Setting

Parameter H3-07 sets the level of the selected input value that is equal to 10 Vdc input at terminal A3 (gain).

Parameter H3-08 sets the level of the selected input value that is equal to 0 V input at terminal A3 (bias).

No.	Name	Setting Range	Default
H3-07	Terminal A3 Gain Setting	-999.9 to 999.9%	100.0%
H3-08	Terminal A3 Bias Setting	-999.9 to 999.9%	0.0%

### ■ H3-09: Terminal A2 Signal Level Selection

Selects the input signal level for analog input A2. Set DIP switch S1 on the terminal board accordingly for a voltage input or current input.

No.	Name	Setting Range	Default
H3-09	Terminal A2 Signal Level Selection	0 to 3	2

#### Setting 0: 0 to 10 Vdc

The input level is 0 to 10 Vdc. [Refer to Setting 0: 0 to 10 Vdc on page 114.](#)

#### Setting 1: -10 to 10 Vdc

The input level is -10 to 10 Vdc. [Refer to Setting 1: -10 to 10 Vdc on page 114.](#)

#### Setting 2: 4 to 20 mA Current Input

The input level is 4 to 20 mA. Negative input values by negative bias or gain settings will be limited to 0%.

#### Setting 3: 0 to 20 mA Current Input

The input level is 0 to 20 mA. Negative input values by negative bias or gain settings will be limited to 0%.

### ■ H3-10: Terminal A2 Function Selection

Determines the function assigned to analog input terminal A2. [Refer to Multi-Function Analog Input Terminal Settings on page 117](#) for a list of functions and descriptions.

No.	Name	Setting Range	Default
H3-10	Terminal A2 Function Selection	0 to 31	0

### ■ H3-11, H3-12: Terminal A2 Gain and Bias Setting

Parameter H3-11 sets the level of the input value selected that is equal to 10 Vdc input or 20 mA input to terminal A2.

Parameter H3-12 sets the level of the input value selected that is equal to 0 V, 4 mA or 0 mA input at terminal A2.

Use both parameters to adjust the characteristics of the analog input signal to terminal A2. The setting works in the same way as parameters H3-03 and H3-04 for analog input A1.

No.	Name	Setting Range	Default
H3-11	Terminal A2 Gain Setting	-999.9 to 999.9%	100.0%
H3-12	Terminal A2 Bias Setting	-999.9 to 999.9%	0.0%

### ■ H3-13: Analog Input Filter Time Constant

Parameter H3-13 sets the time constant for a first order filter that will be applied to the analog inputs.

An analog input filter prevents erratic drive control when using a “noisy” analog reference. Drive operation becomes more stable as the programmed time becomes longer, but it also becomes less responsive to rapidly changing analog signals.

No.	Name	Setting Range	Default
H3-13	Analog Input Filter Time Constant	0.00 to 2.00 s	0.03 s

### ■ H3-14: Analog Input Terminal Enable Selection

When one of the multi-function digital input parameters is set for “Analog input enable” (H1-□□ = C), the value set to H3-14 determines which analog input terminals are enabled and which terminals are disabled when the input is closed. All analog input terminals will be enabled all of the time if H1-□□ is not set to C.

No.	Name	Setting Range	Default
H3-14	Analog Input Terminal Enable Selection	1 to 7	7

**Setting 1: A1 only enabled**

**Setting 2: A2 only enabled**

**Setting 3: A1 and A2 only enabled**

**Setting 4: A3 only enabled**

**Setting 5: A1 and A3 only enabled**

**Setting 6: A2 and A3 only enabled**

**Setting 7: All analog input terminals enabled**

### ■ H3-16 to H3-18: Terminal A1/A2/A3 Offset

Set the offset level of the selected input value to terminals A1, A2, or A3 that is equal to 0 Vdc input. These parameters rarely require adjustment.

No.	Name	Setting Range	Default
H3-16	Terminal A1 Offset	-500 to 500	0
H3-17	Terminal A2 Offset	-500 to 500	0
H3-18	Terminal A3 Offset	-500 to 500	0

### ■ Multi-Function Analog Input Terminal Settings

See [Table 1.40](#) for information on how H3-02, H3-10, and H3-06 determine functions for terminals A1, A2, and A3.

**Note:** The scaling of all input functions depends on the gain and bias settings for the analog inputs. Set these to appropriate values when selecting and adjusting analog input functions.

**Table 1.40 Multi-Function Analog Input Terminal Settings**

Setting	Function	Page	Setting	Function	Page
0	Frequency Bias	<a href="#">117</a>	F	Through Mode	<a href="#">119</a>
1	Frequency Gain	<a href="#">118</a>	10	Forward Torque Limit	<a href="#">119</a>
2	Auxiliary Frequency Reference 1	<a href="#">118</a>	11	Reverse Torque Limit	
3	Auxiliary Frequency Reference 2	<a href="#">118</a>	12	Regenerative Torque limit	
4	Output Voltage Bias	<a href="#">118</a>	13	Torque Limit Using Torque Reference/Speed Limit	<a href="#">119</a>
5	Accel/Decel Time Gain	<a href="#">118</a>	14	Torque Compensation	<a href="#">119</a>
6	DC Injection Braking Current	<a href="#">118</a>	15	General Torque Limit	<a href="#">119</a>
7	Torque Detection Level	<a href="#">118</a>	16	Differential PID Feedback	<a href="#">119</a>
8	Stall Prevention Level During Run	<a href="#">119</a>	17 <1>	Motor Thermistor (NTC)	<a href="#">119</a>
9	Output Frequency Lower Limit Level	<a href="#">119</a>	1F	Through Mode	<a href="#">119</a>
B	PID Feedback	<a href="#">119</a>	30	DriveWorksEZ Analog Input 1	<a href="#">119</a>
C	PID Setpoint	<a href="#">119</a>	31	DriveWorksEZ Analog Input 2	
D	Frequency Bias	<a href="#">119</a>	32	DriveWorksEZ Analog Input 3	
E	Motor Temperature (PTC Input)	<a href="#">119</a>			

<1> This function is available in models CIMR-A□4A0930 to 4A1200 and A1000 HHP.

#### Setting 0: Frequency Bias

The input value of an analog input set to this function will be added to the analog frequency reference value. When the frequency reference is supplied by a different source other than the analog inputs, this function will have no effect. Use this setting also when only one of the analog inputs is used to supply the frequency reference.

## 1.7 H: Terminal Functions

By default, analog inputs A1 and A2 are set for this function. Simultaneously using A1 and A2 increases the frequency reference by the total of all inputs.

Example: If the analog frequency reference from analog input terminal A1 is 50% and a bias of 20% is applied by analog input terminal A2, the resulting frequency reference will be 70% of the maximum output frequency.

### Setting 1: Frequency Gain

The input value of an analog input set to this function will be multiplied with the analog frequency reference value.

Example: If the analog frequency reference from analog input terminal A1 is 80% and a gain of 50% is applied from analog input terminal A2, the resulting frequency reference will be 40% of the maximum output frequency.

### Setting 2: Auxiliary Reference 1

Sets the auxiliary frequency reference 1 when multi-step speed operation is selected. [Refer to Multi-Step Speed Selection on page 59](#) for details.

### Setting 3: Auxiliary Reference 2

Sets the auxiliary frequency reference 2 when multi-step speed operation is selected. [Refer to Multi-Step Speed Selection on page 59](#) for details.

### Setting 4: Output Voltage Bias

Voltage bias boosts the output voltage of the V/f curve as a percentage of the maximum output voltage (E1-05). Available only when using V/f Control.

### Setting 5: Accel/Decel Time Gain

Adjusts the gain level for the acceleration and deceleration times set to parameters C1-01 through C1-08.

The drive acceleration time is calculated by multiplying the gain level to C1-□□ as follows:

$C1-□□ \times \text{Accel/decel time gain} = \text{Drive accel/decel time}$

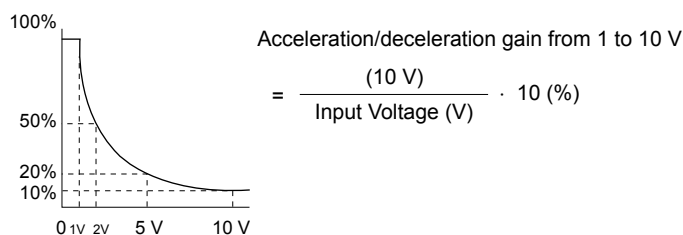

Figure 1.78 Accel/Decel Time Gain with Analog Input Terminal

### Setting 6: DC Injection Braking Current

The current level used for DC Injection Braking is set as a percentage of the drive rated current.

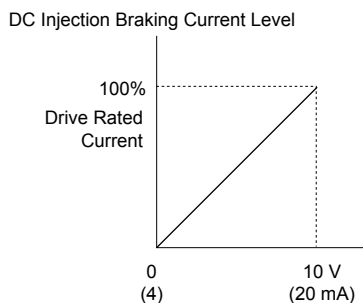

Figure 1.79 DC Injection Braking Current Using an Analog Input Terminal

### Setting 7: Torque Detection Level

Using this setting, the overtorque/undertorque detection level for torque detection 1 (L6-01) can be set by an analog input. The analog input replaces the level set to L6-02. An analog input of 100% (10 V or 20 mA) sets a torque detection level equal to 100% drive rated current/motor rated torque. Adjust the analog input gain if higher detection level settings are required. [Refer to L6: Torque Detection on page 146](#) for details on torque detection.

**Setting 8: Stall Prevention Level**

Allows an analog input signal to adjust the Stall Prevention level. [Figure 1.80](#) shows the setting characteristics. The drive will use the lower value of the Stall Prevention level set to L3-06 or the level coming from the selected analog input terminal.

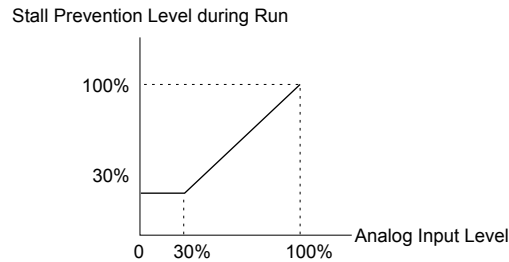

**Figure 1.80** Stall Prevention During Run Using an Analog Input Terminal

**Setting 9: Output Frequency Lower Limit Level**

The user can adjust the lower limit of the output frequency using an analog input signal.

**Setting B: PID Feedback**

Supplies the PID feedback value. This setting requires PID operation to be enabled in b5-01. [Refer to PID Feedback Input Methods on page 34.](#)

**Setting C: PID Setpoint**

Supplies the PID setpoint value and makes the frequency reference selected in parameter b1-01 no longer the PID setpoint. PID operation to be enabled in b5-01 to use this setting. [Refer to PID Setpoint Input Methods on page 34.](#)

**Setting D: Frequency Bias**

The input value of an analog input set to this function will be added to the frequency reference. This function can be used with any frequency reference source.

**Setting E: Motor Temperature**

In addition to motor overload fault detection oL1, it is possible to use a Positive Temperature Coefficient (PTC) thermistor for motor insulation protection. [Refer to Motor Protection Using a Positive Temperature Coefficient \(PTC\) Thermistor on page 128](#) for a detailed explanation.

**Setting F, 1F: Through Mode**

When set to F or 1F, an input does not affect any drive function, but the input level can still be read out by a PLC via a communication option or MEMOBUS/Modbus communications.

**Setting 10, 11, 12, 15: Forward, Reverse, Regenerative, General Torque Limit (OLV, CLV, AOLV/PM, CLV/PM)**

**Note:** PM motor control modes are not available in A1000 HHP drive models.

These functions set a torque limit using analog inputs for different operating conditions. [Refer to L7: Torque Limit on page 149](#) for details.

**Setting 13: Torque Limit Using Torque Reference/Speed Limit**

Sets the torque reference (when in Torque Control) or the torque limit (when in Speed Control). [Refer to Setting the Torque Reference, Speed Limit, and Torque Compensation Values on page 68](#) for details.

**Setting 14: Torque Compensation**

Sets a torque compensation value when using Torque Control. [Refer to Setting the Torque Reference, Speed Limit, and Torque Compensation Values on page 68](#) for details.

**Setting 16: Differential PID Feedback**

If an analog value is set for this function, the PID controller is set for differential feedback. The difference of the PID feedback input value and the differential feedback input value builds the feedback value used to calculate the PID input. [Refer to PID Feedback Input Methods on page 34.](#)

**Setting 17: Motor Thermistor (NTC)**

Used as a complement or a substitution for oL1. [Refer to Motor Protection Using an NTC Thermistor Input on page 130](#) for details.

**Setting 30, 31, 32: DriveWorksEZ Analog Inputs 1, 2, and 3**

These settings are for DriveWorksEZ functions. Normally there is no need to change or apply these settings.

### ◆ H4: Multi-Function Analog Outputs

These parameters assign functions to analog output terminals FM and AM for monitoring a specific aspect of drive performance.

#### ■ H4-01, H4-04: Multi-Function Analog Output Terminal FM, AM Monitor Selection

Sets the desired drive monitor parameter  $U\Box-\Box\Box$  to output as an analog value via terminal FM and AM. *Refer to U: Monitor Parameters on page 169* for a list of all monitors. The “Analog Output Level” column indicates whether a monitor can be used for analog output.

Example: Enter “103” for U1-03.

No.	Name	Setting Range	Default
H4-01	Multi-Function Analog Output Terminal FM Monitor Selection	000 to 999	102
H4-04	Multi-Function Analog Output Terminal AM Monitor Selection	000 to 999	103

A setting of 031 or 000 applies no drive monitor to the analog output. With this setting, terminal functions as well as FM and AM output levels can be set by a PLC via a communication option or MEMOBUS/Modbus (through mode).

#### ■ H4-02, H4-03: Multi-Function Analog Output Terminal FM Gain and Bias H4-05, H4-06: Multi-Function Analog Output Terminal AM Gain and Bias

Parameters H4-02 and H4-05 set the terminal FM and AM output signal level when the value of the selected monitor is at 100%. Parameters H4-03 and H4-06 set the terminal FM and AM output signal level when the value of the selected monitor is at 0%. Both are set as a percentage, where 100% equals 10 Vdc or 20 mA analog output and 0% equals 0 V or 4 mA. The output voltage of both terminals is limited to +/-10 Vdc.

The output signal range can be selected between 0 to +10 Vdc or -10 to +10 Vdc, or 4 to 20 mA using parameter H4-07 and H4-08. *Figure 1.81* illustrates how gain and bias settings work.

No.	Name	Setting Range	Default
H4-02	Multi-Function Analog Output Terminal FM Gain	-999.9 to 999.9%	100.0%
H4-03	Multi-Function Analog Output Terminal FM Bias	-999.9 to 999.9%	0.0%
H4-05	Multi-Function Analog Output Terminal AM Gain	-999.9 to 999.9%	50.0%
H4-06	Multi-Function Analog Output Terminal AM Bias	-999.9 to 999.9%	0.0%

#### Using Gain and Bias to Adjust Output Signal Level

When viewing a gain setting parameter (H4-02 or H4-05) on the digital operator, the analog output will supply a voltage signal equal to 100% of the monitor value (including changes made from bias and gain settings). When viewing a bias setting parameter (H4-03 or H4-06), the analog output voltage will supply a signal equal to 0% monitor value.

Example 1: Set H4-02 to 50% for an output signal of 5 V at terminal FM when the monitored value is at 100%.

Example 2: Set H4-02 to 150% for an output signal of 10 V at terminal FM when the monitored value is at 76.7%.

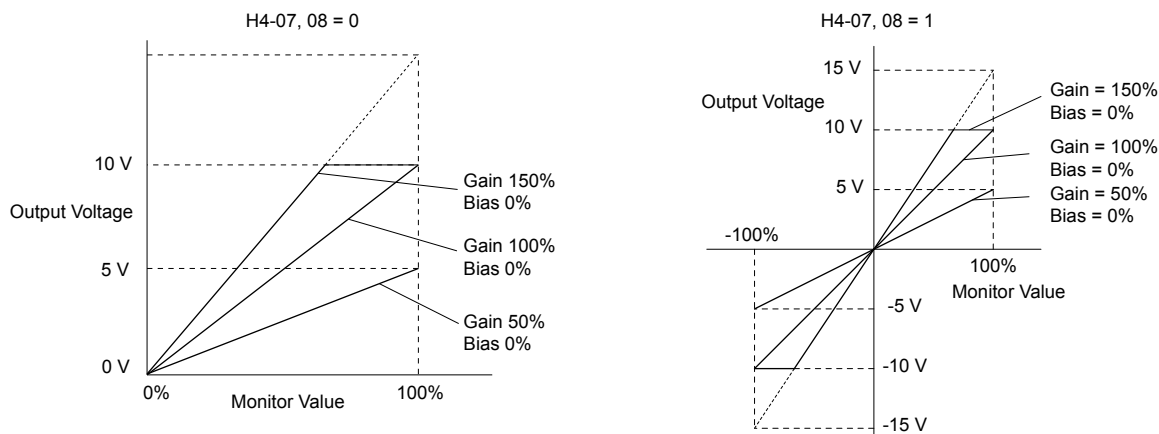

Figure 1.81 Analog Output Gain and Bias Setting Example 1 and 2

Example 3: Set H4-03 to 30% for an output signal of 3 V at terminal FM when the monitored value is at 0%.



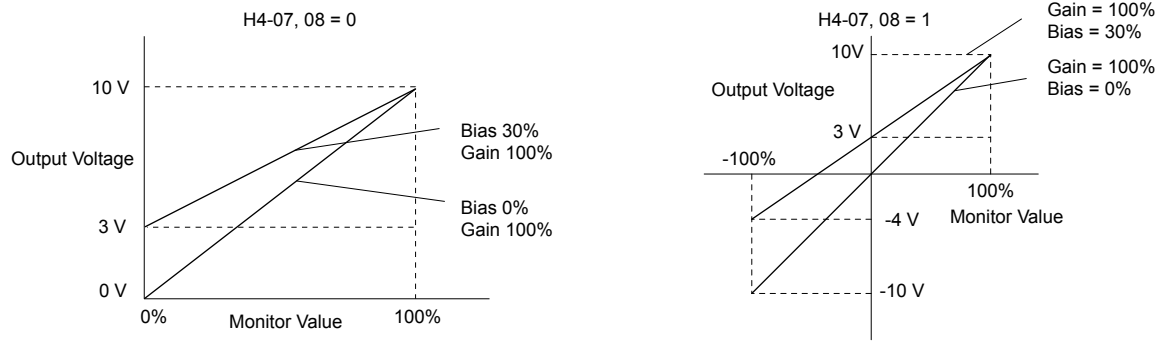

Figure 1.82 Analog Output Gain and Bias Setting Example 3

■ **H4-07, H4-08: Multi-Function Analog Output Terminal FM, AM Signal Level Selection**

Sets the voltage output level of U parameter (monitor parameter) data to terminal FM and terminal AM using parameters H4-07 and H4-08.

Set jumper S5 on the terminal board accordingly when changing these parameters.

No.	Name	Setting Range	Default
H4-07	Multi-Function Analog Output Terminal FM Signal Level Selection	0 to 2	0
H4-08	Multi-Function Analog Output Terminal AM Signal Level Selection	0 to 2	0

Setting 0: 0 to 10 V

Setting 1: -10 V to 10 V

Setting 2: 4 to 20 mA

◆ **H5: MEMOBUS/Modbus Serial Communication**

Serial communication is possible in the drive using the built-in RS-422/485 port (terminals R+, R-, S+, S-) and programmable logic controllers (PLCs) or similar devices running the MEMOBUS/Modbus protocol.

The H5-□□ parameters set the drive for MEMOBUS/Modbus Communications.

■ **H5-01: Drive Slave Address**

Sets the drive slave address used for communications.

**Note:** Cycle the power after changing this parameter to enable the new setting.

No.	Name	Setting Range	Default
H5-01	Drive Slave Address	0 to FFH <1>	1FH

<1> If the address is set to 0, no response will be provided during communications.

Each slave drive must be assigned a unique slave address for serial communications to work. Setting H5-01 to any value besides 0 assigns the drive its address in the network. Slave addresses do not need to be assigned in sequential order, but no two drives may share the same address.

■ **H5-02: Communication Speed Selection**

Sets the MEMOBUS/Modbus communications speed.

**Note:** Cycle the power after changing this parameter to enable the new setting.

No.	Name	Setting Range	Default
H5-02	Communication Speed Selection	0 to 5	3

H5-02	Communication Speed	H5-02	Communication Speed
0	1200 bps	5	38400 bps
1	2400 bps	6	57600 bps

## 1.7 H: Terminal Functions

H5-02	Communication Speed	H5-02	Communication Speed
2	4800 bps	7	76800 bps
3	9600 bps	8	115200 bps
4	19200 bps		

### ■ H5-03: Communication Parity Selection

Sets the parity used for communications.

**Note:** Cycle the power after changing this parameter to enable the new setting.

No.	Name	Setting Range	Default
H5-03	Communication Parity Selection	0 to 2	0

**Setting 0: No parity**

**Setting 1: Even parity**

**Setting 2: Odd parity**

### ■ H5-04: Stopping Method after Communication Error

Selects the stopping method after a communications error (CE) has occurred.

No.	Name	Setting Range	Default
H5-04	Stopping Method after CE	0 to 3	3

**Setting 0: Ramp to stop (uses the deceleration time currently enabled)**

**Setting 1: Fast Stop (uses the deceleration time in C1-09)**

**Setting 2: Coast to stop**

**Setting 3: Alarm only (continue operation)**

### ■ H5-05: Communication Fault Detection Selection

Enables or disables the CE detection for communications.

No.	Name	Setting Range	Default
H5-05	Communication Fault Detection Selection	0 or 1	1

**Setting 0: Disabled**

No communication error detection. The drive continues operation.

**Setting 1: Enabled**

If the drive does not receive data from the master for longer than the time set to H5-09, then a CE fault will be triggered and the drive will operate as determined by parameter H5-04.

### ■ H5-06: Drive Transmit Wait Time

Sets the time the drive waits after receiving data from a master until responding data.

No.	Name	Setting Range	Default
H5-06	Drive Transmit Wait Time	5 to 65 ms	5 ms

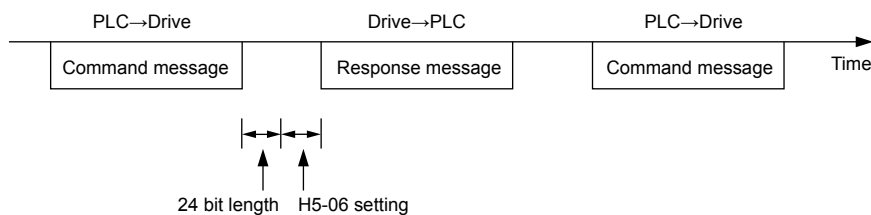

Figure 1.83 Drive Transmit Wait Time Setting

### ■ H5-07: RTS Control Selection

Enables or disables RTS control.

No.	Name	Setting Range	Default
H5-07	RTS Control Selection	0 or 1	1

**Setting 0: Disabled. RTS is always on.**

Use this setting with point-to-point or multi-drop RS-422 communications.

**Setting 1: Enabled. RTS switches while sending.**

Use this setting when using RS-485 signals for communications or when using the RS-422 signals for point-to-point communications.

**■ H5-09: CE Detection Time**

Sets the time the communications must be lost before the drive triggers a CE fault.

No.	Name	Setting Range	Default
H5-09	CE Detection Time	0.0 to 10.0 s	2.0 s

**■ H5-10: Unit Selection for MEMOBUS/Modbus Register 0025H**

Sets the unit for the output voltage monitor value in MEMOBUS/Modbus register 0025H.

No.	Name	Setting Range	Default
H5-10	Unit Selection for MEMOBUS/Modbus Register 0025H	0 or 1	0

**Setting 0: 0.1 V units****Setting 1: 1 V units****■ H5-11: Communications Enter Function Selection**

Selects whether an Enter command is necessary to change parameter values via MEMOBUS/Modbus communications. *Refer to Enter Command on page 344.*

No.	Name	Setting Range	Default
H5-11	Communications Enter Function Selection	0 or 1	1

**Setting 0: Enter command necessary**

Parameter changes become effective after an Enter command. An Enter command must only be sent after the last parameter change, not for each single parameter.

**Setting 1: Enter command not necessary**

Parameter value changes become effective immediately without the need to send an Enter command.

**■ H5-12: Run Command Method Selection**

Selects the type of sequence used when the Run command source is set to MEMOBUS/Modbus communications (b1-02, b1-16 = 2).

No.	Name	Setting Range	Default
H5-12	Run Command Method Selection	0 or 1	0

**Setting 0: FWD/Stop, REV/Stop**

Setting bit 0 of MEMOBUS/Modbus register will start and stop the drive in the forward direction. Setting bit 1 will start and stop the drive in reverse.

**Setting 1: Run/Stop, FWD/REV**

Setting bit 0 of MEMOBUS/Modbus register will start and stop the drive. Setting bit 1 changes the direction.

**◆ H6: Pulse Train Input/Output**

A one-track pulse train signal with a maximum frequency of 32 kHz can be input to the drive at terminal RP. This pulse train signal can be used as the frequency reference, for PID functions, or as the speed feedback signal in V/f Control.

The pulse output monitor terminal MP can output drive monitor values as a pulse train signal with a maximum frequency of 32 kHz in sinking or sourcing mode.

Use parameters H6-□□ to set the scale and other aspects of the pulse input terminal RP and pulse output terminal MP.

### ■ H6-01: Pulse Train Input Terminal RP Function Selection

Selects the function of pulse train input terminal RP.

No.	Name	Setting Range	Default
H6-01	Pulse Train Input Terminal RP Function Selection	0 to 3	0

#### Setting 0: Frequency reference

If the pulse input is set for this function and the frequency reference source is set to pulse input (b1-01, b1-15 = 4), the drive reads the frequency value from terminal RP.

#### Setting 1: PID feedback value

Using this setting, the feedback value for PID control can be supplied as a pulse signal at terminal RP. [Refer to b5: PID Control on page 33](#) for details on PID control.

#### Setting 2: PID setpoint value

Using this setting, the setpoint value for PID control can be supplied as a pulse signal at terminal RP. [Refer to b5: PID Control on page 33](#) for details on PID control.

#### Setting 3: Speed feedback (V/f Control with Simple Speed Feedback)

This setting can be used in V/f control to increase the speed control precision by using a motor speed feedback signal. The drive reads the speed feedback from terminal RP, compares it to the frequency reference and compensates the motor slip using a speed regulator (ASR, set up in the C5-□□ parameters) like shown in [Figure 1.84](#). Because input terminal RP is incapable of detecting motor direction, a separate way of determining motor direction still needs to be set up:

##### 1. Using a Digital Input

If a digital input programmed for “Forward/reverse detection” (H1-□□ = 7E) is closed, the drive assumes reverse rotation. If open, then the drive assumes that the motor is rotating forwards.

##### 2. Using the Frequency Reference Direction

If no digital input is set to “Forward/reverse detection” (H1-□□ = 7E), the drive uses the direction of the frequency reference as the direction for the speed feedback detected at the pulse input.

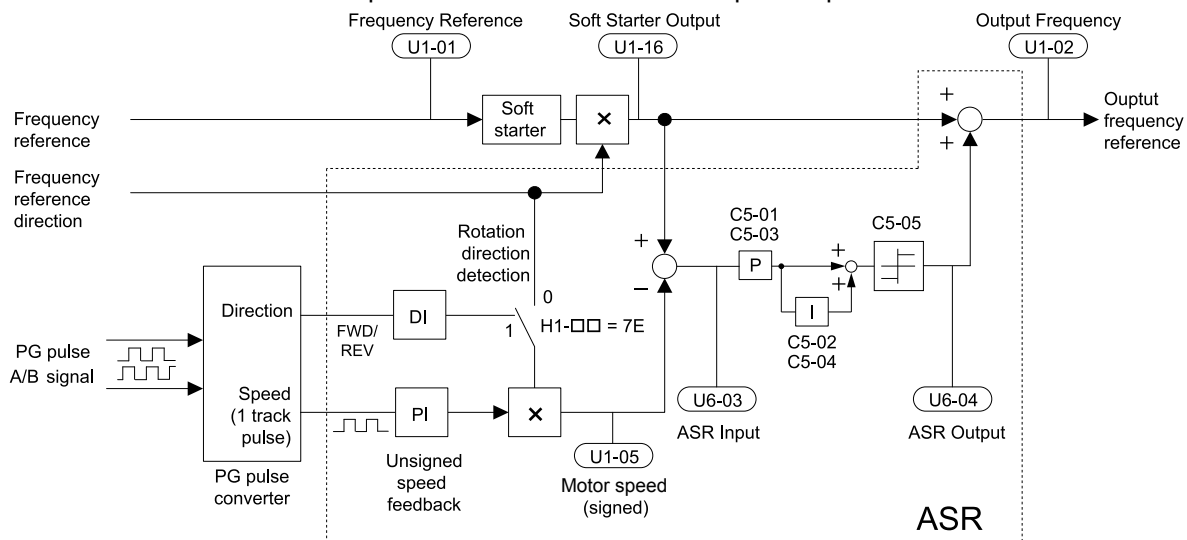

Figure 1.84 Speed Control with ASR in V/f with Simple Speed Feedback

#### Enabling V/f Control with Simple Speed Feedback:

1. Set the drive to V/f Control (A1-02 = 0).
2. Connect the motor speed pulse signal to the pulse input RP, set H6-01 = 3, and set the pulse signal frequency that is equal to the maximum speed to H6-02 (pulse input scaling). Make sure the pulse input bias (H6-04) is 0% and the gain (H6-03) is 100%.
3. Decide on the signal used for detecting the direction. Set H1-□□ = 7F if using a digital input.
4. Use the ASR gain and integral time parameters described in [C5: Automatic Speed Regulator \(ASR\)](#) on page 53 for adjusting the responsiveness.

**Note:** 1. C5 parameters will appear when using V/f Control (A1-02 = 0) and when the pulse input RP function is set for simple PG feedback in V/f Control (H6-01 = 3).

2. If running two motors from the same drive, V/f Control with simple PG feedback can be used for motor 1 only.

### ■ H6-02: Pulse Train Input Scaling

Sets the pulse signal frequency that is equal to 100% of the input value selected in parameter H6-01.

No.	Name	Setting Range	Default
H6-02	Pulse Train Input Scaling	100 to 32000 Hz	1440 Hz

### ■ H6-03: Pulse Train Input Gain

Sets the level of the input value selected in H6-01 when a pulse train signal with the frequency set in H6-02 is input to terminal RP.

No.	Name	Setting Range	Default
H6-03	Pulse Train Input Gain	0.0 to 1000.0%	100.0%

### ■ H6-04: Pulse Train Input Bias

Sets the level of the input value selected in H6-01 when no signal (0 Hz) is input to terminal RP.

No.	Name	Setting Range	Default
H6-04	Pulse Train Input Bias	-100.0 to 100.0%	0.0%

### ■ H6-05: Pulse Train Input Filter Time

Sets the pulse train input filter time constant in seconds.

No.	Name	Setting Range	Default
H6-05	Pulse Train Input Filter Time	0.00 to 2.00 s	0.10 s

### ■ H6-06: Pulse Train Monitor Selection

Selects the monitor to output as a pulse train signal via terminal MP. Enter the three digits in U□-□□ to indicate which monitor to output. *Refer to U: Monitor Parameters on page 169* for a complete list of monitors. Monitors that can be selected by H6-06 appear in the table below.

No.	Name	Setting Range	Default
H6-06	Pulse Train Monitor Selection	000 <1>, 031, 101, 102, 105, 116, 501, 502, 801 to 809	102

<1> Set "000" when the terminal is not used or when using the terminal in the through mode.

### ■ H6-07: Pulse Train Monitor Scaling

Sets the output frequency at terminal MP when the specified monitor item is at 100%. Set H6-06 to 102 and H6-07 to 0 to make the pulse train monitor output synchronous to the output frequency.

No.	Name	Setting Range	Default
H6-07	Pulse Train Monitor Scaling	0 to 32000 Hz	1440 Hz

### ■ H6-08: Pulse Train Input Minimum Frequency

Sets the minimum output frequency detected by the pulse train input. Increasing this setting reduces the time the drive needs to react to changes in the input signal.

- The pulse input value becomes 0 when the pulse input frequency falls below this level.
- Enabled when H6-01 = 0, 1, or 2.
- When simple speed feedback in V/f Control is set as the function for terminal RP (H6-01 = 3), the minimum frequency becomes the detection time for PG disconnect (F1-14).

No.	Name	Setting Range	Default
H6-08	Pulse Train Input Minimum Frequency	0.1 to 1000.0 Hz	0.5 Hz

# 1.8 L: Protection Functions

## ◆ L1: Motor Protection

### ■ L1-01: Motor Overload Protection Selection

The drive has an electronic overload protection function that estimates the motor overload level based on output current, output frequency, thermal motor characteristics, and time. When the drive detects a motor overload an oL1 fault is triggered and the drive output shuts off.

L1-01 sets the overload protection function characteristics according to the motor being used.

No.	Name	Setting Range	Default
L1-01	Motor Overload Protection Selection	0 to 6	Determined by A1-02

- Note:**
1. When the motor protection function is enabled (L1-01 ≠ 0), an oL1 alarm can be output through one of the multi-function outputs by setting H2-01 to 1F. The output closes when the motor overload level reaches 90% of the oL1 detection level.
  2. Set L1-01 to a value between 1 and 5 when running a single motor from the drive to select a method to protect the motor from overheat. An external thermal relay is not necessary.

#### Setting 0: Disabled (motor overload protection is not provided)

Use this setting if no motor overheat protection is desired or if multiple motors are connected to a single drive. If multiple motors are connected to a single drive, install a thermal relay for each motor as shown in **Figure 1.85**.

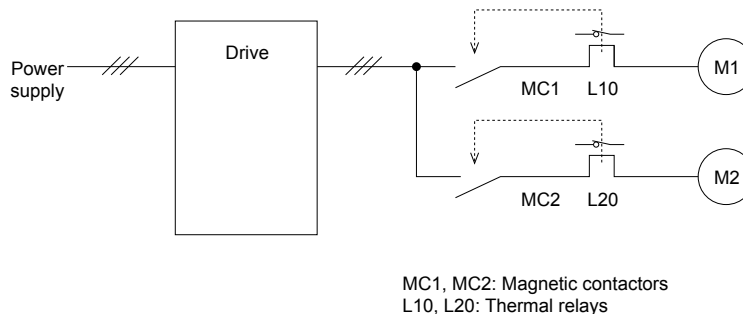

**Figure 1.85 Example of Protection Circuit Design for Multiple Motors**

**NOTICE:** Thermal protection cannot be provided when running multi-motors simultaneously with the same drive, or when using motors with a relatively high current rating compared to other standard motors (such as a submersible motor). Failure to comply could result in motor damage. Disable the electronic overload protection of the drive (L1-01 = "0: Disabled") and protect each motor with individual motor thermal overloads.

**Note:** Close MC1 and MC2 before operating the drive. MC1 and MC2 cannot be switched off during run.

#### Setting 1: General-purpose motor (standard self-cooled)

Because the motor is self-cooled, the overload tolerance drops when the motor speed is lowered. The drive appropriately adjusts the electrothermal trigger point according to the motor overload characteristics, protecting the motor from overheat throughout the entire speed range.

Overload Tolerance	Cooling Ability	Overload Characteristics
<p>Rated Speed=100% Speed                      A: Max. speed for 200LJ and above                      B: Max. speed for 160MJ to 180 LJ                      C: Max. speed for 132MJ and below</p>	<p>Motor designed to operate from line power.                      Motor cooling is most effective when running at rated base frequency (check the motor nameplate or specifications).</p>	<p>Continuous operation at less than line power frequency with 100% load can trigger motor overload protection (oL1). A fault is output and the motor will coast to stop.</p>

**Setting 2: Drive dedicated motor (speed range for constant torque: 1:10)**

Use this setting when operating a drive duty motor that allows constant torque in a speed range of 1:10. The drive will allow the motor to run with 100% load from 10% up to 100% speed. Running at slower speeds with full load can trigger an overload fault.

Overload Tolerance	Cooling Ability	Overload Characteristics
	<p>Motor is designed to effectively cool itself even at low speeds.</p>	<p>Continuous operation with 100% load from 6 Hz to E1-06, Motor Base Frequency.</p>

**Setting 3: Vector motor (speed range for constant torque: 1:100)**

Use this setting when operating a drive-dedicated motor that allows constant torque in a speed range of 1:100. This motor type is allowed to run with 100% load from 1% up to 100% speed. Running slower speeds with full load can trigger an overload fault.

Overload Tolerance	Cooling Ability	Overload Characteristics
	<p>Motor is designed to effectively cool itself at speeds near 0.6 Hz.</p>	<p>Continuous operation with 100% load from 0.6 Hz to E1-06, Motor Base Frequency. Continuous operation below 0.6 Hz may cause an oL1 or oL2 fault.</p>

**Setting 6: General-purpose motor**

**Note:** General-purpose motors are designed with a base speed that operates at line frequency (50/60 Hz depending on geographic region).

Because the motor is self-cooled, the overload tolerance drops when the motor speed is lowered. The drive appropriately adjusts the electrothermal trigger point according to the motor overload characteristics and protects the motor from overheat throughout the entire speed range.

Overload Tolerance	Cooling Ability	Overload Characteristics
	<p>Motor designed to operate from line power. Motor cooling is most effective when running at rated base frequency (check the motor nameplate or specifications)</p>	<p>Continuous operation at less than line power frequency with 100% load can trigger motor overload protection (oL1). A fault is output and the motor will coast to stop.</p>

## 1.8 L: Protection Functions

### ■ L1-02: Motor Overload Protection Time

Sets the detection time of motor overheat due to overload. This setting rarely requires adjustment, but should correlate with the motor overload tolerance protection time for performing a hot start.

No.	Name	Setting Range	Default
L1-02	Motor Overload Protection Time	0.1 to 5.0 minutes	1.0 minutes

Defaulted to operate with an allowance of 150% overload operation for one minute in a hot start.

**Figure 1.86** illustrates an example of the electrothermal protection operation time using a general-purpose motor operating at the value of E1-06, Motor Base Speed, with L1-02 set to one minute.

During normal operation, motor overload protection operates in the area between a cold start and a hot start.

- Cold start: Motor protection operation time in response to an overload situation that was suddenly reached when starting a stationary motor.
- Hot start: Motor protection operation time in response to an overload situation that occurred during sustained operation at rated current.

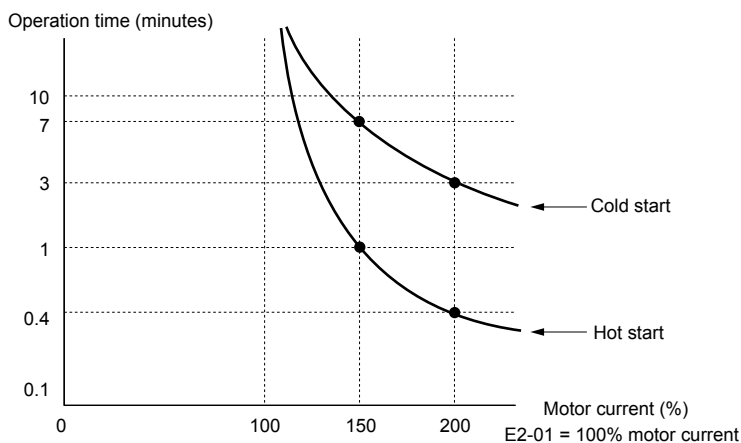

Figure 1.86 Motor Protection Operation Time

### ■ Motor Protection Using a Positive Temperature Coefficient (PTC) Thermistor

Connect a motor PTC can to an analog input of the drive for motor overheat protection.

The motor overheat alarm level triggers an oH3 alarm and the drive continues the operation selected in L1-03. The overheat fault level triggers an oH4 fault, outputs a fault signal, and the drive stops the motor using the stop method selected in L1-04.

Connect the PTC between terminals AC and A3 and set jumper S4 on the terminal board to “PTC” as shown in **Figure 1.87**. Set H3-05 to 0 and H3-06 to E.

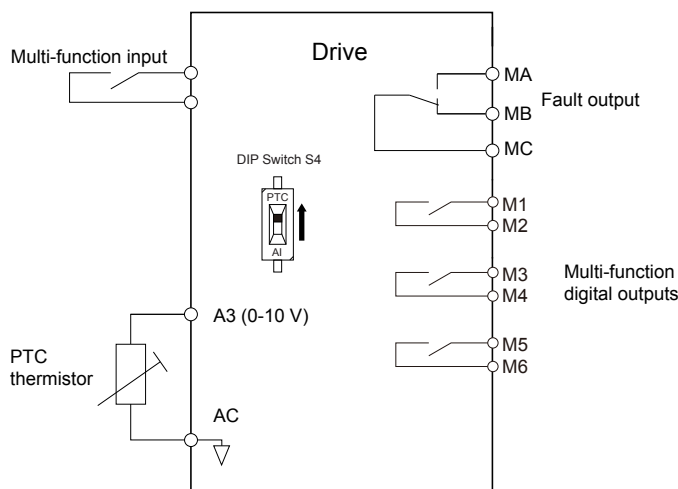

Figure 1.87 Connection of a Motor PTC



The PTC must exhibit the characteristics shown in *Figure 1.88* in one motor phase. The motor overload protection of the drive expects 3 of these PTCs to be connected in a series.

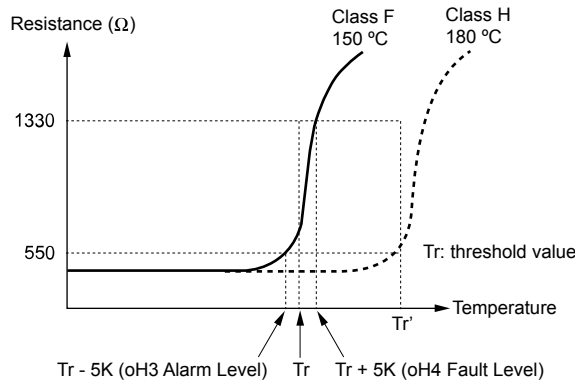

Figure 1.88 Motor PTC Characteristics

Set up overheat detection using a PTC using parameters L1-03, L1-04, and L1-05 as explained in the following sections.

**■ L1-03: Motor Overheat Alarm Operation Selection (PTC input)**

Sets the drive operation when the PTC input signal reaches the motor overheat alarm level (oH3).

No.	Name	Setting Range	Default
L1-03	Motor Overheat Alarm Operation Selection (PTC input)	0 to 3	3

**Setting 0: Ramp to stop**

The drive stops the motor using the deceleration time 1 set in parameter C1-02.

**Setting 1: Coast to stop**

The drive output is switched off and the motor coasts to stop.

**Setting 2: Fast Stop**

The drive stops the motor using the Fast Stop time set in parameter C1-09.

**Setting 3: Alarm only**

The operation is continued and an oH3 alarm is displayed on the digital operator.

**■ L1-04: Motor Overheat Fault Operation Selection (PTC input)**

Sets the drive operation when the PTC input signal reaches the motor overheat fault level (oH4).

No.	Name	Setting Range	Default
L1-04	Motor Overheat Fault Operation Selection (PTC input)	0 to 2	1

**Setting 0: Ramp to Stop**

The drive stops the motor using the deceleration time 1 set in parameter C1-02.

**Setting 1: Coast to Stop**

The drive output is switched off and the motor coasts to stop.

**Setting 2: Fast Stop**

The drive stops the motor using the Fast Stop time set in parameter C1-09.

**■ L1-05: Motor Temperature Input Filter Time (PTC input)**

Sets a filter on the PTC input signal to prevent erroneous detection of a motor overheat fault.

No.	Name	Setting Range	Default
L1-05	Motor Temperature Input Filter Time (PTC input)	0.00 to 10.00 s	0.20 s

**■ L1-13: Continuous Electrothermal Operation Selection**

Determines whether to hold the current value of the electrothermal motor protection (L1-01) when the power supply is interrupted.

## 1.8 L: Protection Functions

No.	Name	Setting Range	Default
L1-13	Continuous Electrothermal Operation Selection	0, 1	1

**Setting 0: Disabled**

**Setting 1: Enabled**

### Motor Protection Using an NTC Thermistor Input

Motor protection is possible for models CIMR-A□4A0930, 4A1200 and A1000 HHP by connecting the NTC thermistor input in the motor windings to one of the drive analog input terminals.

This enables the drive to provide torque compensation in response to changes in motor temperature and protect the motor from overheating.

If the NTC input signal using the drive multi-function analog input terminal exceeds the overheat alarm level set to L1-16 (or L1-18 for motor 2), then “oH5” will flash on the digital operator screen. The drive will respond to the alarm according to the setting of L1-20 (default setting is to continue operation when an oH5 alarm occurs).

*Figure 1.89* shows a circuit using the NTC thermistor and the terminal resistance values. Set DIP switch S1 on the drive to “V” for voltage input when wiring the NTC thermistor input to terminal A2 on the drive.

**Note:** This example assumes that H3-10 = 17, H3-09 = 10, and that DIP switch S1 has been set for voltage input.

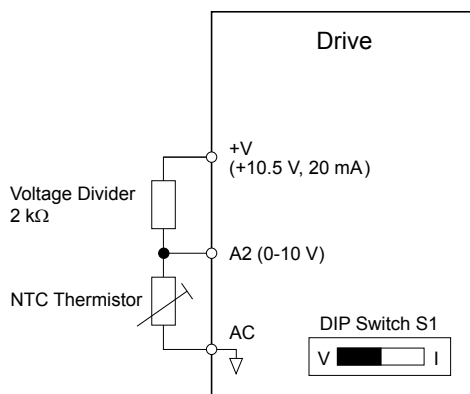

**Figure 1.89 Motor Protection Circuit Using NTC Input**

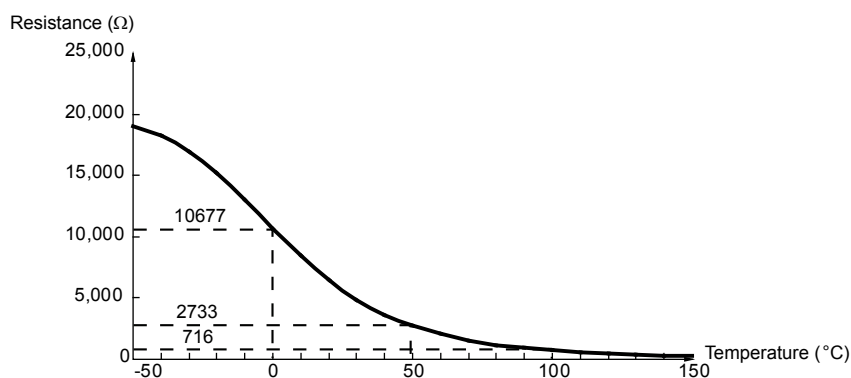

**Figure 1.90 Temperature and Resistance of NTC Thermistor**

L1-15 to L1-20 can determine the overheat protection settings using the NTC thermistor input. Parameter descriptions are listed below.

### L1-15: Motor 1 Thermistor Selection (NTC)

**Note:** This parameter is only available in models CIMR-A□4A0930, 4A1200 and A1000 HHP.

No.	Name	Setting Range	Default
L1-15	Motor 1 Thermistor Selection (NTC)	0, 1	0

**Setting 0: Disabled****Setting 1: Enabled****■ L1-16: Motor 1 Overheat Temperature oH5 Level**

**Note:** This parameter is only available in models CIMR-A□4A0930, 4A1200 and A1000 HHP.

Sets the temperature that will trigger an overheat fault (oH5) for motor1.

No.	Name	Setting Range	Default
L1-16	Motor 1 Overheat Temperature oH5 Level	50 to 200 °C	120

**■ L1-17: Motor 2 oH5 Fault Select**

**Note:** This parameter is only available in models CIMR-A□4A0930, 4A1200 and A1000 HHP.

No.	Name	Setting Range	Default
L1-17	Motor 2 oH5 Fault Select	0 to 2	0

**Setting 0: Disabled****Setting 1: Enabled 1****Setting 2: Enabled 2****■ L1-18: Motor 2 Overheat Temperature**

**Note:** This parameter is only available in models CIMR-A□4A0930, 4A1200 and A1000 HHP.

Sets the temperature that will trigger an overheat fault (oH5) for motor 2.

No.	Name	Setting Range	Default
L1-18	Motor 2 Overheat Temperature	50 to 200 °C	120

**■ L1-19: Operation Time at Thermistor Disconnect (NTC)**

**Note:** This parameter is only available in models CIMR-A□4A0930, 4A1200 and A1000 HHP.

Determines drive operation when a thermistor disconnect fault (THo) occurs.

No.	Name	Setting Range	Default
L1-19	Operation Time at Thermistor Disconnect (NTC)	0 to 3	3

**Setting 0: Ramp to stop**

The drive stops the motor using the deceleration time set in parameter C1-02.

**Setting 1: Coast to stop**

The drive output is switched off and the motor coasts to a stop.

**Setting 2: Fast stop**

The drive stops the motor using the Fast stop time set in parameter C1-09.

**Setting 3: Alarm only**

The operation is continued and a THo alarm is displayed on the digital operator.

**■ L1-20: Operation at Motor Overheat**

**Note:** This parameter is only available in models CIMR-A□4A0930, 4A1200 and A1000 HHP.

Determines drive operation when a motor overheat fault (oH5) occurs.

No.	Name	Setting Range	Default
L1-20	Operation at Motor Overheat	0 to 3	1

**Setting 0: Ramp to stop**

The drive stops the motor using the deceleration time set in parameter C1-02.

**Setting 1: Coast to stop**

The drive output is switched off and the motor coasts to a stop.

## 1.8 L: Protection Functions

### Setting 2: Fast stop

The drive stops the motor using the Fast stop time set in parameter C1-09.

### Setting 3: Alarm only

The operation is continued and an oH5 alarm is displayed on the digital operator.

### ■ L1-21: Thermally Sensitive Resistor Selection

Sets the type of thermistor input for Motor 1 and Motor 2.

No.	Name	Setting Range	Default
L1-21	Thermally Sensitive Resistor Selection	0, 1	0

### Setting 0: H5 Table Selection

### Setting 1: Pt100 Table Selection

## ◆ L2: Momentary Power Loss Ride-Thru

### ■ L2-01: Momentary Power Loss Operation Selection

When a momentary power loss occurs (DC bus voltage falls below the level set in L2-05), the drive can automatically return to the operation it was performing prior to the power loss based on certain conditions.

No.	Name	Setting Range	Default
L2-01	Momentary Power Loss Operation Selection	0 to 5	0

### Setting 0: Disabled (default)

If power is not restored within 15 ms, a Uv1 fault will result and the motor coasts to stop.

### Setting 1: Recover within L2-02

When a momentary power loss occurs, the drive output will be shut off. If the power returns within the time set to parameter L2-02, the drive will perform Speed Search and attempt to resume operation. If the power does not return within this time, it will trigger a Uv1 fault.

### Setting 2: Recover as long as CPU has power

When a momentary power loss occurs, the drive output will be shut off. If the power returns and the drive control circuit has power, the drive will attempt to perform Speed Search and resume the operation. This will not trigger a Uv1 fault.

### Setting 3: Kinetic Energy Backup (KEB) Ride-Thru operation within L2-02

The drive decelerates using regenerative energy from the motor until the time set in L2-02 has expired. It then tries to accelerate back to the frequency reference. If the power does not return within the time set to L2-02, it will trigger a Uv1 fault and the drive output will shut off. The type of KEB operation is determined by the L2-29 setting.

### Setting 4: KEB Ride-Thru as long as CPU has power

The drive decelerates using regenerative energy from the motor until the power returns and then restarts. If the motor comes to a stop before the power returns, the drive loses control power and the drive output shuts off. A Uv1 fault is not triggered. The type of KEB operation is determined by the L2-29 setting.

### Setting 5: Ramp to stop with KEB deceleration

The drive ramps to stop using the regenerative energy from the motor. Even if the power is restored, the drive will continue to decelerate until the motor comes to a complete stop. The type of KEB operation is determined by the L2-29 setting. If an input terminal set for KEB 1 (H1-□□ = 65, 66) is triggered while the drive is decelerating, it will accelerate back up to speed when the input is released.

### Notes on Settings 1 through 5

- “Uv” will flash on the operator while the drive is attempting to recover from a momentary power loss. A fault signal is not output at this time.
- A Momentary Power Loss Unit is available to allow for a longer momentary power loss ride through time in models CIMR-A□2A0004 to 2A0056 and 4A0002 to 4A0031. This option makes it possible to continue running the drive after up to two seconds of power loss.
- When using a magnetic contactor between the motor and the drive, keep the magnetic contactor closed as long as the drive performs KEB operation or attempts to restart with Speed Search.
- Keep the Run command active during KEB operation or the drive cannot accelerate back to the frequency reference when the power returns.

- When L2-01 is set to 3, 4, or 5, KEB Ride-Thru will be executed as specified in L2-29.

## ■ KEB Ride-Thru Function

When the drive detects a power loss, KEB Ride-Thru decelerates the motor and uses regenerative energy to keep the main circuit operating. Despite power loss, the drive output is not interrupted.

Choose between Single Drive KEB Ride-Thru 1 and 2 (L2-29 = 0 or 1 for applications driven by a single drive.

Choose between System KEB Ride-Thru 1 and 2, (L2-29 = 2 or 3) for applications where multiple drives have to perform KEB operation while keeping a certain speed ratio.

### Single Drive KEB Ride-Thru 1 (L2-29 = 0)

After KEB Ride-Thru begins, the drive uses regenerative energy from the motor to keep the DC bus voltage at the level set to L2-11 while adjusting the rate of deceleration based on the time set to L2-06. The user must set L2-06 properly to prevent Uv1 and ov faults.

**Note:** Shorten the KEB deceleration time (L2-06) if undervoltage (Uv1) occurs in the DC bus. Increase the KEB deceleration time if overvoltage (ov) occurs.

### Single Drive KEB Ride-Thru 2 (L2-29 = 1)

The drive uses information about the inertia of the connected machinery to determine the deceleration rate necessary to keep the DC bus voltage at the level set in parameter L2-11. The resulting deceleration time is calculated based on the system inertia and cannot be adjusted.

### System KEB Ride-Thru 1 (L2-29 = 2)

The drive decelerates at the KEB deceleration time set to L2-06. L2-06 is the time required to decelerate from the current frequency reference to 0. Using this setting, multiple drives can decelerate while keeping the speed ratio constant between those drives. This function requires a braking resistor and disregards the voltage level in the DC bus.

### System KEB Ride-Thru 2 (L2-29 = 3)

The drive decelerates based on the KEB deceleration time set to L2-06 while monitoring the DC bus voltage. If the voltage level rises, the drive briefly holds the frequency before continuing to decelerate.

## ■ KEB Ride-Thru Start

KEB operation is triggered independently of the selected KEB operation mode. When the KEB function is selected as the function to be executed when power loss operation occurs (L2-01 = 3, 4, or 5), then KEB Ride-Thru will be activated if one of the following conditions becomes true:

- A digital input programmed for H1-□□ = 65 or 66 is activated. This will start KEB operation using the mode selected in parameter L2-29.
- A digital input programmed for H1-□□ = 7A or 7B is activated. This will automatically select Single KEB Ride-Thru 2, disregarding the setting of L2-29.
- The DC bus voltage fell below the level specified in L2-05. The KEB operation will start as specified in L2-29.

**Note:** Attempting to simultaneously assign KEB Ride-Thru 1 and 2 to input terminals will trigger an oPE3 error.

When using a digital input to trigger KEB operation and the device controlling the input acts relatively slow, set a minimum KEB operation time in parameter L2-10. In the example below, the DC bus voltage triggers KEB operation and a digital input triggers the Hold command.

## 1.8 L: Protection Functions

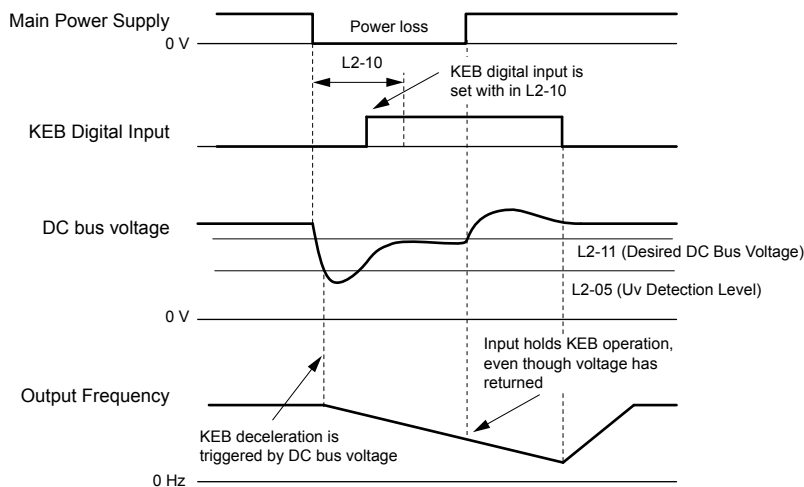

Figure 1.91 KEB Operation Using a KEB Input

### ■ KEB Ride-Through End Detection

The KEB function end detection depends on the setting of parameter L2-01 and whether a digital input programmed for KEB (H1-□□ = 65, 66, 7A, 7B) is used.

#### KEB Ride-Through Operation in L2-02, Input Terminals Not Used

Here, L2-01 = 3 and the input terminals have not been set for KEB Ride-Through (H1-□□ does not equal 65, 66, 7A, 7B). After decelerating for the time set in parameter L2-02, the drive ends KEB operation and attempts to accelerate back to the frequency reference. A Uv1 fault occurs and the drive output shuts off if the power does not return within the time set to L2-02.

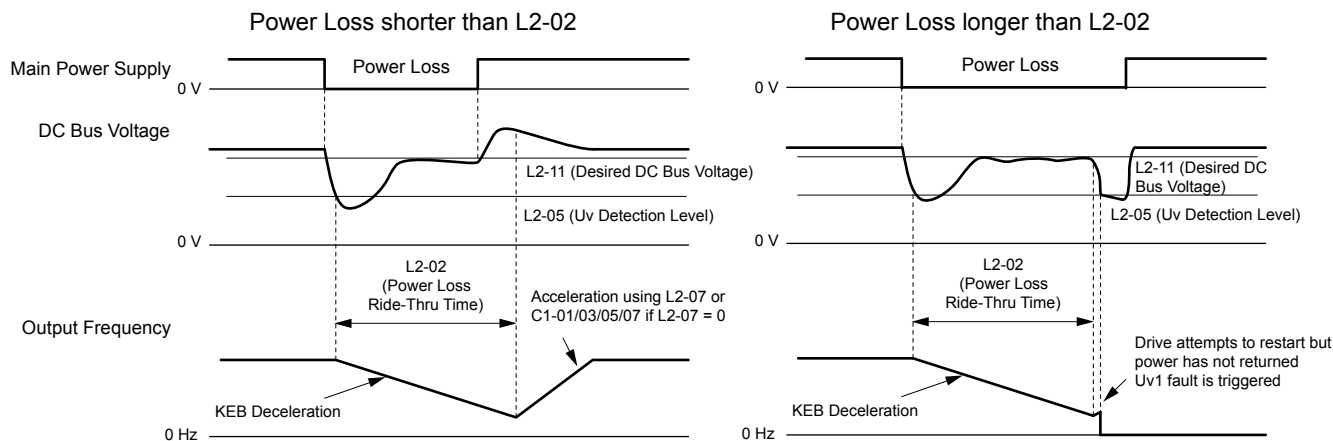

Figure 1.92 KEB Operation Using L2-02, Without KEB Input

#### KEB Ride-Through Operation Within L2-02, Input Terminals Used

Here, L2-01 = 3 and an input terminal is set to issue KEB Ride-Through (H1-□□ = 65, 66, 7A, 7B). After decelerating for the time set in parameter L2-02, the drive checks the DC bus voltage and the status of the digital input. If the DC bus voltage is still below the level set in L2-11 or if the KEB digital input is still active, KEB deceleration continues. If the voltage level has risen above the value set to L2-11, then normal operation is resumed.

**Note:** If L2-10 is set to a longer time than L2-02, the drive checks the DC bus voltage level and the status of the terminal assigned to KEB Ride-Through after the time set to L2-02 passes. The drive will then try to restart.

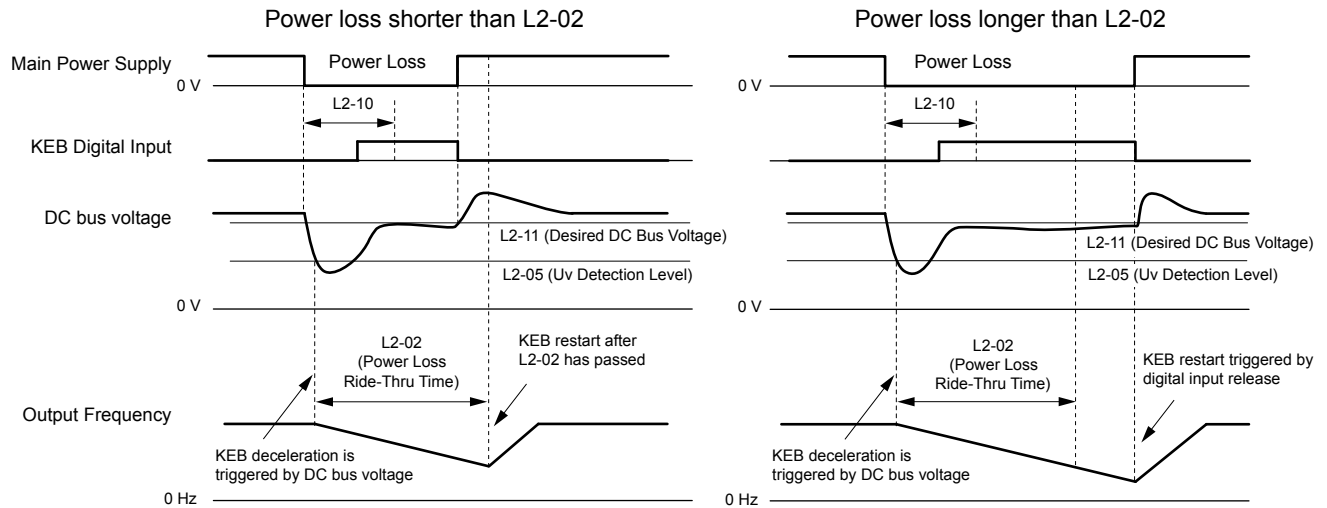

Figure 1.93 KEB Operation Using L2-02 and KEB Input

**KEB Ride-Thru Operation as Long as CPU Has Power, KEB Input Not Used**

Here, L2-01 = 4 and the input terminals have not been set for KEB Ride-Thru (H1-□□ does not equal 65, 66, 7A, 7B). After decelerating for the time set to parameter L2-10, the drive checks the DC bus voltage level. Deceleration continues if the DC bus voltage is lower than the level set in L2-11. Normal operation resumes when the DC bus voltage rises above the value of L2-11.

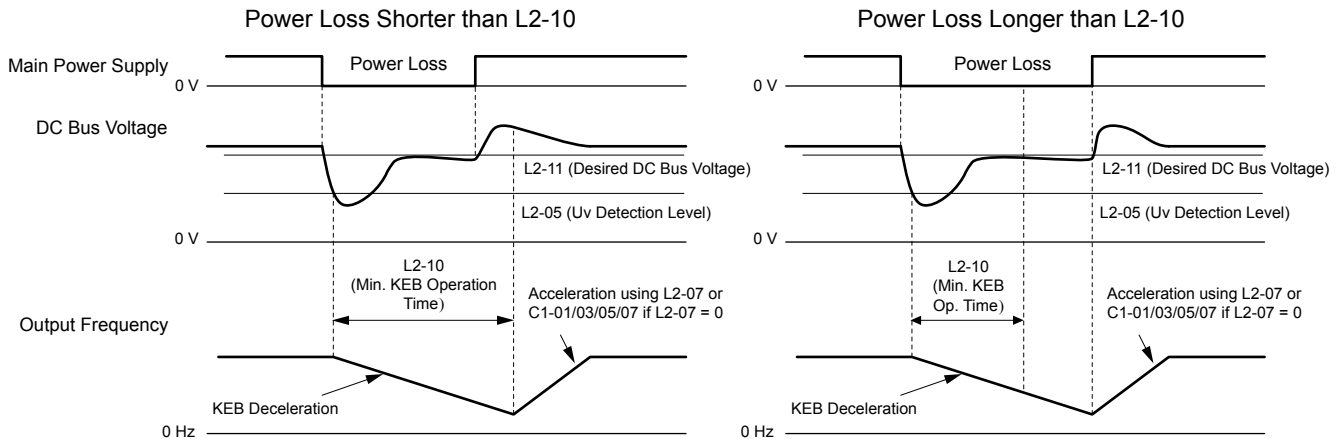

Figure 1.94 KEB Operation Using L2-10, Without KEB Input

**KEB Ride-Thru Operation as Long as CPU Has Power, KEB Input Used**

Here, L2-01 = 3 and an input terminal is set to issue KEB Ride-Thru (H1-□□ = 65, 66, 7A, 7B). After decelerating for the time set to parameter L2-10, the drive checks the DC bus voltage and the status of the digital input. Deceleration continues if the DC bus voltage is still below the level set in L2-11 or if the digital input assigned to KEB Ride-Thru is still active. Normal operation resumes when the DC bus voltage rises above the value of L2-11 and the terminal that initiated KEB Ride-Thru is released.

## 1.8 L: Protection Functions

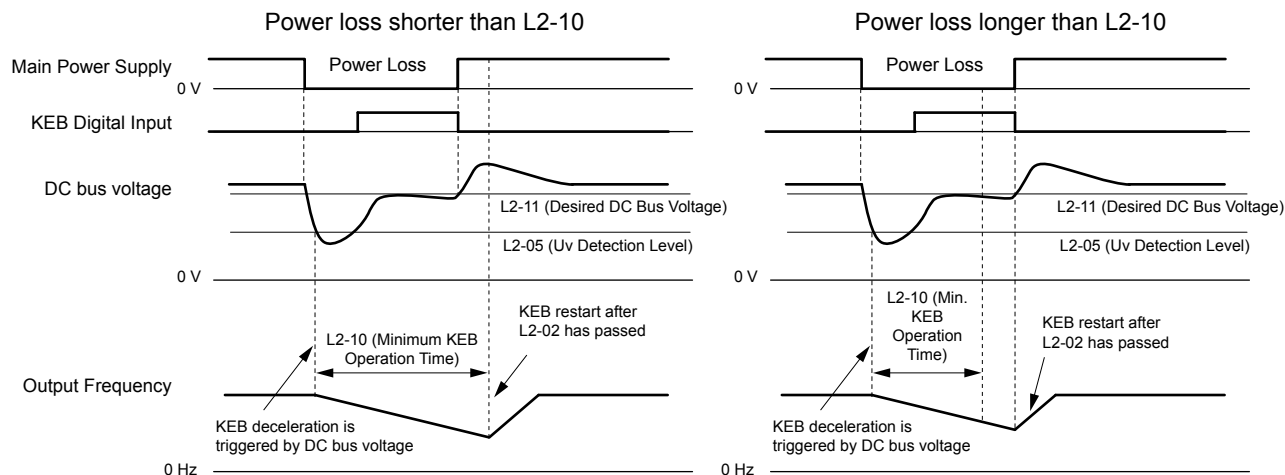

Figure 1.95 KEB Operation Using L2-10 and KEB Input

### L2-01 = 5

KEB operation ends when the motor has come to a stop, even if the power returns and the digital input terminal that initiated KEB Ride-Thru is cleared.

### KEB Operation Wiring Example

Figure 1.96 shows a wiring example to trigger the KEB Ride-Thru at power loss using an undervoltage relay. When a power loss occurs, the undervoltage relay triggers KEB Ride-Thru at terminal S6 (H1-06 = 65, 66, 7A, 7B). Note that using System KEB Ride-Thru requires an additional dynamic braking option.

- Note:**
1. Do not switch off the Run command during momentary power loss. If the Run command is shut off, the drive will not accelerate back to speed when the power is restored.
  2. A dynamic braking option is required to use System KEB 1 (L2-29 = 2).

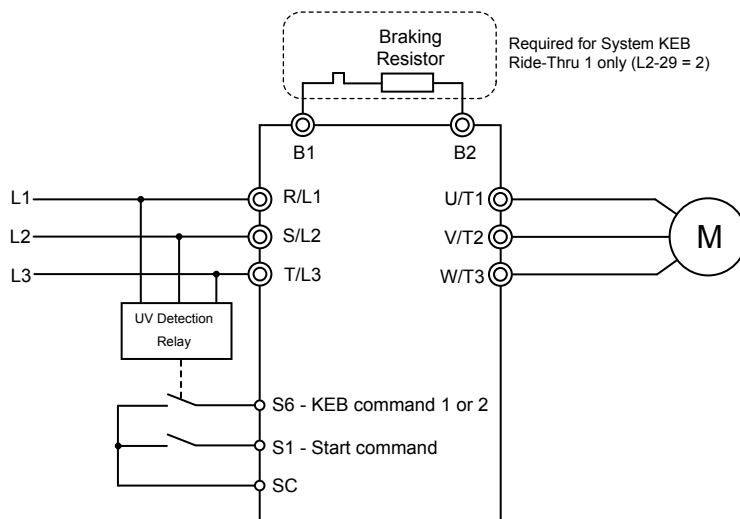

Figure 1.96 KEB Function Wiring Example

### Parameters for KEB Ride-Thru

Table 1.41 lists parameters needed to set up KEB Ride-Thru depending on the type of KEB Ride-Thru selected in L2-29.



Table 1.41 KEB Function Related Adjustments

Parameter	Name	Setting Instructions	KEB Mode (L2-29)			
			0	1	2	3
C1-09	Fast Stop Time	<ul style="list-style-type: none"> <li>• Increase if an overvoltage fault occurs during KEB deceleration.</li> <li>• Decrease if an undervoltage fault occurs during KEB deceleration.</li> </ul>	YES	NO	NO	NO
C2-03	S-Curve at Deceleration Start	<ul style="list-style-type: none"> <li>• Shorten if undervoltage occurs immediately after KEB Ride-Thru is triggered.</li> <li>• Lengthen this setting if overvoltage occurs immediately after KEB operation starts.</li> </ul>	YES	NO	YES	YES
L2-05	Undervoltage Detection Level	Increase if an undervoltage fault occurs at KEB operation start to let the drive detect power loss more quickly.	YES	YES	YES	YES
L2-06	KEB Deceleration Time	<ul style="list-style-type: none"> <li>• Increase if an overvoltage fault occurs during KEB deceleration</li> <li>• Decrease if an undervoltage fault occurs during KEB deceleration</li> </ul>	NO	NO	YES	YES
L2-07	KEB Acceleration Time	Adjust to the desired acceleration time. If set to 0, standard acceleration times are used (C1-01, C1-03, C1-05, C1-07).	YES	YES	YES	YES
L2-08	Frequency Gain at KEB Start	<ul style="list-style-type: none"> <li>• Increase if an undervoltage fault occurs immediately after KEB operation starts.</li> <li>• Decrease if an overvoltage fault occurs immediately after KEB operation starts.</li> </ul>	YES	NO	YES	YES
L2-10	KEB Detection Time	<ul style="list-style-type: none"> <li>• Increase when a digital input is set for KEB Ride-Thru and an undervoltage fault occurs after power was lost because the device controlling the input does not react quickly enough.</li> <li>• If the DC bus voltage overshoots after KEB Ride-Thru begins (and no input terminal is set to KEB Ride-Thru), increase L2-10 to longer than the overshoot.</li> </ul>	YES	YES	YES	YES
L2-11	Desired DC Bus Voltage during KEB	<ul style="list-style-type: none"> <li>• Set to approximately 1.22 times the input voltage for Single Drive KEB Ride-Thru 2.</li> <li>• Set to approximately 1.4 times the input voltage for Single Drive KEB Ride-Thru 1 and System KEB Ride-Thru modes.</li> </ul>	YES	YES	YES	YES
L3-20	Main Circuit Adjustment Gain	<ul style="list-style-type: none"> <li>• Increase this setting in steps of 0.1 if overvoltage or undervoltage occurs at the beginning of deceleration</li> <li>• Reduce if torque ripple occurs during deceleration while executing KEB Ride-Thru.</li> </ul>	NO	YES	NO	NO
L3-21	Accel/Decel Rate Calculation Gain	<ul style="list-style-type: none"> <li>• Reduce L3-21 in steps of 0.05 if there is a fairly large speed or current ripple.</li> <li>• Decreasing this setting too much can cause a slow DC bus voltage control response, and may lead to problems with overvoltage or undervoltage.</li> </ul>	NO	YES	NO	NO
L3-24	Motor Acceleration Time	Set the motor acceleration time as described on page	NO	YES	NO	NO
L3-25	Load Inertia Ratio	Set the load/inertia ratio as described on page.	NO	YES	NO	NO

■ **L2-02: Momentary Power Loss Ride-Thru Time**

Sets the maximum time allowed to ride through a power loss. If power loss operation exceeds this time, the drive will attempt to accelerate back to the frequency reference. This parameter is valid if L2-01 = 1 or 3.

**Note:** The amount of time the drive is capable of recovering after a power loss is determined by the capacity of the drive. Drive capacity determines the upper limit for L2-02.

No.	Name	Setting Range	Default
L2-02	Momentary Power Loss Ride-Thru Time	0.0 to 25.5 s	Determined by C6-01 and o2-04

■ **L2-03: Momentary Power Loss Minimum Baseblock Time**

Sets the minimum baseblock time when power is restored following a momentary power loss. This determines the time the drive waits for the residual voltage in the motor to dissipate. Increase this setting if overcurrent or overvoltage occurs at the beginning of Speed Search, after a power loss, or during DC Injection Braking.

## 1.8 L: Protection Functions

No.	Name	Setting Range	Default
L2-03	Momentary Power Loss Minimum Baseblock Time	0.1 to 5.0 s	Determined by C6-01 and o2-04

### ■ L2-04: Momentary Power Loss Voltage Recovery Ramp Time

Sets the time for the drive to restore the output voltage to the level specified by the V/f pattern after Speed Search. The setting value determines the time for the voltage to go from 0 V to the maximum voltage.

No.	Name	Setting Range	Default
L2-04	Momentary Power Loss Voltage Recovery Ramp Time	0.0 to 5.0 s	Determined by C6-01 and o2-04

### ■ L2-05: Undervoltage Detection Level (Uv)

Determines the voltage at which a Uv1 fault is triggered or at which the KEB function is activated. This setting rarely needs to be changed.

No.	Name	Setting Range	Default
L2-05	Undervoltage Detection Level	300 to 420 Vdc <1>	Determined by A1-02, C6-01, E1-01 and o2-04 <2>

<1> Values shown are specific to 400 V class drives. Multiply the values by 1.4375 for 575 V class drives. Multiply the values by 1.725 for 690 V class drives.

<2> The default setting for 400 V class drives depends on whether the drive input voltage is over 400 V or under 400 V.

- Note:**
1. Install an AC reactor option on the input side of the power supply when setting L2-05 below the default value to prevent damage to drive circuitry.
  2. If using KEB Ride-Thru and L2-05 is set too low, then undervoltage in the DC bus (Uv1) will be triggered before KEB Ride-Thru can be executed. Take caution not to set this value too low.

### ■ L2-07: KEB Acceleration Time

Sets the time to reaccelerate from the speed when KEB was deactivated to the frequency reference.

When set to 0.0 s, the drive will accelerate to speed according to the active deceleration time set by C1-01, C1-03, C1-05, or C1-07.

No.	Name	Setting Range	Default
L2-07	KEB Acceleration Time	0.00 to 6000.0 s <1>	0.00 s

<1> Setting range is determined by the accel/decel time units set in C1-10. If the time is set in units of 0.01 s (C1-10 = 0), the setting range becomes 0.00 to 600.00 s.

### ■ L2-10: KEB Detection Time (Minimum KEB Time)

Determines the duration of KEB Ride-Thru operation after it is triggered. [Refer to KEB Ride-Thru End Detection on page 134](#) for details.

No.	Name	Setting Range	Default
L2-10	KEB Detection Time	0 to 2000 ms	50 ms

### ■ L2-11: DC Bus Voltage Setpoint during KEB

Determines the setpoint (target value) for the DC bus voltage during Single KEB Ride-Thru 2. For Single KEB Ride-Thru 1 and System KEB Ride-Thru, parameter L2-11 defines the voltage level to end KEB Ride-Thru.

No.	Name	Setting Range	Default
L2-11	DC Bus Voltage Setpoint during KEB	300 to 800 Vdc <1>	Determined by E1-01

<1> Values shown are specific to 400 V class drives. Multiply the values by 1.4375 for 575 V class drives. Multiply the values by 1.725 for 690 V class drives.

## ◆ L3: Stall Prevention

The motor may experience excessive slip because it cannot keep up with the frequency reference when the load is too high or acceleration and deceleration times are too short. If the motor stalls during acceleration, it usually causes an overcurrent fault (oC), drive overload (oL2), or motor overload (oL1). If the motor slips during deceleration, it can cause excessive regenerative power to flow back into the DC bus capacitors, and eventually cause the drive to fault out from overvoltage (oV). The Stall Prevention Function prevents the motor from stalling and while allowing the motor to reach the desired speed without requiring the user to change the acceleration or deceleration time settings. The Stall Prevention function can be set separately for acceleration, operating at constant speeds, and deceleration.

### ■ L3-01: Stall Prevention Selection during Acceleration

Stall Prevention during acceleration prevents tripping with overcurrent (oC), motor overload (oL1), or drive overload (oL2) faults common when accelerating with heavy loads.

L3-01 determines the type of Stall prevention the drive should use during acceleration.

No.	Name	Setting Range	Default
L3-01	Stall Prevention Selection during Acceleration	0 to 2 <1>	1

<1> Setting 2 is not available for OLV/PM.

#### Setting 0: Disabled

No Stall Prevention is provided. If the acceleration time is too short, the drive may not be able to get the motor up to speed fast enough, causing an overload fault.

#### Setting 1: Enabled

Enables Stall Prevention during acceleration. Operation varies depending on the control mode.

- V/f Control, V/f Control with PG, and Open Loop Vector Control:

Acceleration is reduced when the output current value exceeds 85% of the level set to parameter L3-02 for a longer than the time set to L3-27. The acceleration stops when the current exceeds L3-02. Acceleration continues when the current falls below L3-02 for longer than the time set to L3-27.

The Stall Prevention level is automatically reduced in the constant power range. *Refer to L3-03: Stall Prevention Limit during Acceleration on page 140.*

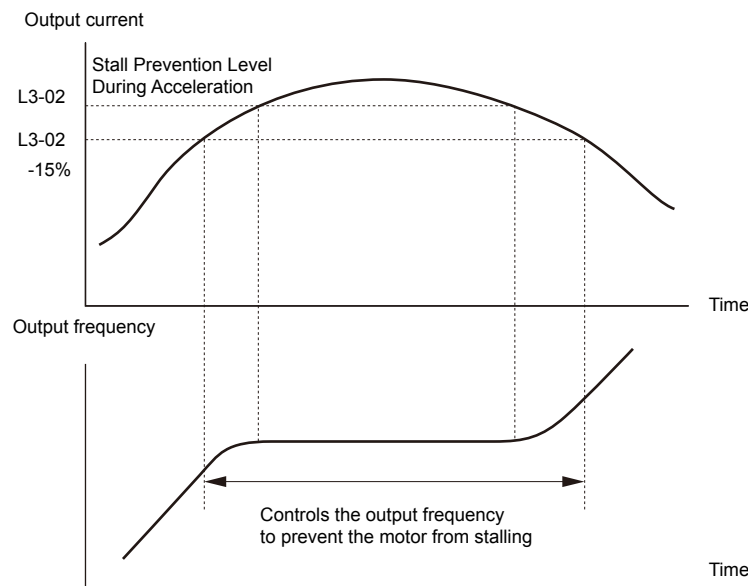
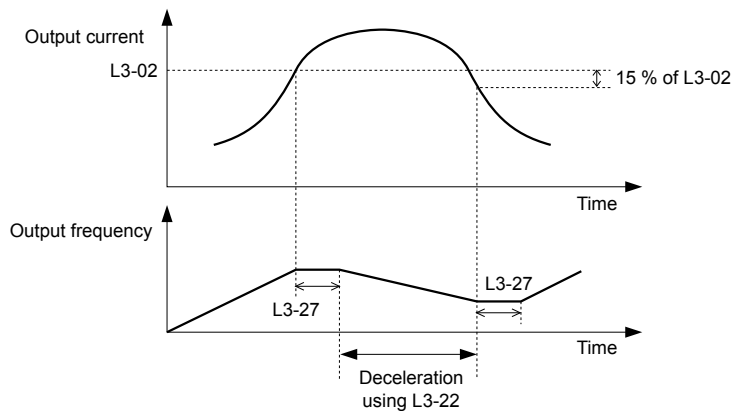

Figure 1.97 Stall Prevention During Acceleration for Induction Motors

- Open Loop Vector Control for PM:

Acceleration stops when the output current reaches the level set to parameter L3-02. When the time set to parameter L3-27 passes, the drive decelerates using the deceleration time set to L3-22 (*Refer to L3-22: Deceleration Time at Stall Prevention during Acceleration on page 140*). Deceleration stops when the current falls below 85% of L3-02. The drive will attempt to reaccelerate after the time set to L3-27.



**Figure 1.98 Stall Prevention During Acceleration for Permanent Magnet Motors**

**Note:** PM motor control modes are not available in A1000 HHP drive models.

### Setting 2: Intelligent Stall Prevention

The drive disregards the selected acceleration time and attempts to accelerate in the minimum time. The acceleration rate is adjusted so the current does not exceed the value set to parameter L3-02.

#### ■ L3-02: Stall Prevention Level during Acceleration

Sets the output current level at which the Stall Prevention during acceleration is activated.

No.	Name	Setting Range	Default
L3-02	Stall Prevention Level during Acceleration	0 to 150% </>	</>

<1> The upper limit and default value is determined by the duty rating and the carrier frequency derating selection (C6-01 and L8-38 respectively).

- Lower L3-02 if stalling occurs when using a motor that is relatively small compared to the drive.
- Also set parameter L3-03 when operating the motor in the constant power range.

#### ■ L3-03: Stall Prevention Limit during Acceleration

The Stall Prevention level is automatically reduced when the motor is operated in the constant power range. L3-03 sets the lower limit for this reduction as a percentage of the drive rated current.

No.	Name	Setting Range	Default
L3-03	Stall Prevention Limit during Acceleration	0 to 100%	50%

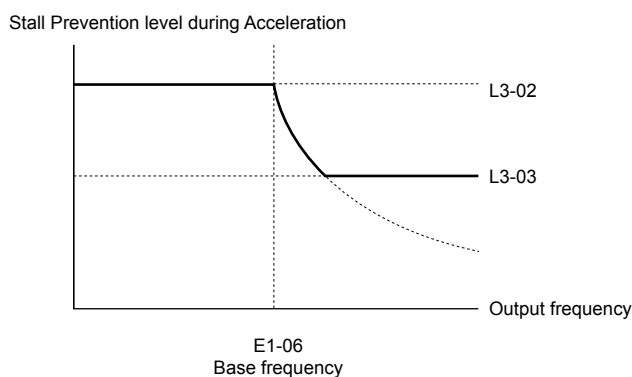

**Figure 1.99 Stall Prevention Level and Limit During Acceleration**

#### ■ L3-22: Deceleration Time at Stall Prevention during Acceleration

Sets the brief deceleration time used when stalling occurs while accelerating a PM motor. When set to 0, this function is disabled and the drive decelerates at the selected deceleration time when stalling occurs.

The function is effective only in OLV/ PM control and when parameter L3-01 is set to 1.

No.	Name	Setting Range	Default
L3-22	Deceleration Time at Stall Prevention During Acceleration	0 to 6000.0 s	0.0 s

**■ L3-04: Stall Prevention Selection during Deceleration**

Stall Prevention during deceleration controls the deceleration based on the DC bus voltage and prevents an overvoltage fault caused by high inertia or rapid deceleration.

No.	Name	Setting Range	Default
L3-04	Stall Prevention Selection During Deceleration	0 to 5 <1> <2>	1

<1> Settings 3 through 5 are not available in OLV/PM. Settings 2 through 5 are not available in AOLV/PM and CLV/PM.

<2> Setting 3 is not available for models CIMR-A□4A0930 and 4A1200. HHP models only have settings 0, 1, 4, and 5

**Setting 0: Disabled**

The drive decelerates according to the set deceleration time. With high inertia loads or rapid deceleration, an overvoltage fault may occur. If an overvoltage fault occurs, use dynamic braking options or switch to another L3-04 selection.

**Setting 1: General-purpose Stall Prevention**

The drive tries to decelerate within the set deceleration time. The drive pauses deceleration when the DC bus voltage exceeds the Stall Prevention level and then continues deceleration when the DC bus voltage drops below that level. Stall Prevention may be triggered repeatedly to avoid an overvoltage fault. The DC bus voltage level for Stall Prevention depends on the input voltage setting E1-01.

Drive Input Voltage	Stall Prevention Level during Deceleration
400 V Class	750 Vdc
575 V Class	930 Vdc
690 V Class	930 Vdc

- Note:**
1. Do not use this setting in combination with a Dynamic Braking Resistor or other dynamic braking options. If Stall Prevention during deceleration is enabled, it will be triggered before the braking resistor option can operate.
  2. This method may lengthen the total deceleration time compared to the set value. If this is not appropriate for the application consider using a dynamic braking option.

Figure 1.100 illustrates the function of Stall Prevention during deceleration.

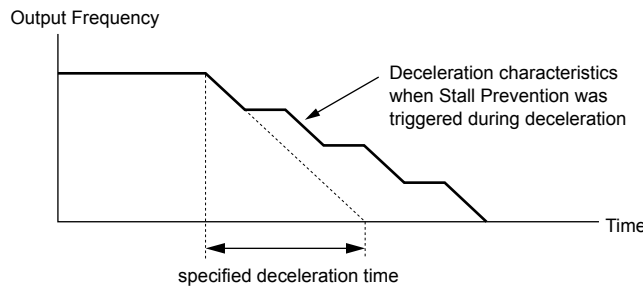

Figure 1.100 Stall Prevention During Deceleration

**Setting 2: Intelligent Stall Prevention**

The drive adjusts the deceleration rate so the DC bus voltage is kept at the level set to parameter L3-17. This produces the shortest possible deceleration time while protecting the motor from stalling. The selected deceleration time is disregarded and the achievable deceleration time cannot be smaller than 1/10 of the set deceleration time.

This function uses the following parameters for adjusting the deceleration rate:

- DC bus voltage gain (L3-20)
- Deceleration rate calculations gain (L3-21)
- Inertia calculations for motor acceleration time (L3-24)
- Load inertia ratio (L3-25)

**Note:** The deceleration time is not constant. Do not use Intelligent Stall Prevention in applications where stopping accuracy is a concern. Use dynamic braking options instead.

## 1.8 L: Protection Functions

### Setting 3: Stall Prevention with dynamic braking option

Enables the Stall Prevention function while using a dynamic braking resistor. Overvoltage problems in the DC bus can occur if Stall Prevention during deceleration is disabled (L3-04) in OLV and a dynamic braking option is installed. Set L3-04 to 3 to remedy this situation.

### Setting 4: Overexcitation Deceleration 1

Overexcitation Deceleration 1 (increasing the motor flux) is faster than deceleration with no Stall Prevention (L3-04 = 0). Setting 4 changes the selected decel time and functions to provide protection from an overvoltage trip. [Refer to Overexcitation Deceleration \(Induction Motors\) on page 157](#) for details.

### Setting 5: Overexcitation Deceleration 2

Overexcitation Deceleration 2 slows down the motor while trying to maintain the DC bus voltage at the level set to parameter L3-17. This function shortens the achievable deceleration time more than by using Overexcitation Deceleration 1. Setting 5 will shorten/lengthen the decel time to maintain the L3-17 bus level. [Refer to Overexcitation Deceleration \(Induction Motors\) on page 157](#) for details.

### ■ L3-05: Stall Prevention Selection during Run

Determines how Stall Prevention works during Run. Stall Prevention during run prevents the motor from stalling by automatically reducing the speed when a transient overload occurs while the motor is running at constant speed.

No.	Name	Setting Range	Default
L3-05	Stall Prevention Selection During Run	0 to 2	1

- Note:**
1. This parameter is available in V/f, V/f w/PG, and OLV/PM.
  2. Stall Prevention during run is disabled when the output frequency is 6 Hz or lower regardless of the L3-05 and L3-06 settings.

### Setting 0: Disabled

Drive runs at the set frequency reference. A heavy load may cause the motor to stall and trip the drive with an oC or oL fault.

### Setting 1: Decelerate using C1-02

If the current exceeds the Stall Prevention level set in parameter L3-06, the drive will decelerate at decel time 1 (C1-02). When the current level drops below the value of L3-06 minus 2% for 100 ms, the drive accelerates back to the frequency reference at the active acceleration time.

### Setting 2: Decelerate using C1-04

Same as setting 1 except the drive decelerates at decel time 2 (C1-04).

### ■ L3-06: Stall Prevention Level during Run

Sets the current level to trigger Stall Prevention during run. Depending on the setting of parameter L3-23, the level is automatically reduced in the constant power range (speed beyond base speed).

The Stall Prevention level can be adjusted using an analog input. [Refer to Multi-Function Analog Input Terminal Settings on page 117](#) for details.

No.	Name	Setting Range	Default
L3-06	Stall Prevention Level During Run	30 to 150 <1>	<1>

<1> The upper limit and default for this setting is determined by C6-01 and L8-38.

### ■ L3-23: Automatic Reduction Selection for Stall Prevention during Run

Reduces the Stall Prevention during run level in the constant power range.

No.	Name	Setting Range	Default
L3-23	Automatic Reduction Selection for Stall Prevention During Run	0, 1	0

### Setting 0: Disabled

The level set in L3-06 is used throughout the entire speed range.

### Setting 1: Enabled

The Stall Prevention level during run is reduced in the constant power range. The lower limit will be 40% of L3-06.

## ■ Overvoltage Suppression Function

Suppresses overvoltage faults by decreasing the regenerative torque limit and slightly increasing the output frequency when the DC bus voltage rises. This function can drive loads with cyclic regenerative operation, such as a punch press or other applications that involve repetitive crank movements.

The regenerative torque limit and the output frequency are adjusted during ov suppression so that the DC bus voltage does not exceed the level set to parameter L3-17. In addition to the parameters explained below, ov suppression also uses these settings for frequency adjustment:

- DC bus voltage gain (L3-20)
- Deceleration rate calculations gain (L3-21)
- Inertia calculations for motor acceleration time (L3-24)
- Load inertia ratio (L3-25)

- Note:**
1. The motor speed will exceed the frequency reference when overvoltage suppression is triggered. Consequently, overvoltage suppression is not appropriate in applications that require a perfect match between the frequency reference and the motor speed.
  2. Disable overvoltage suppression when using a braking resistor.
  3. Overvoltage may still occur if there is a sudden increase to a regenerative load.
  4. This function is enabled only when operating just below the maximum frequency. Overvoltage suppression does not increase the output frequency beyond the maximum frequency. If the application requires this, increase the maximum frequency and change the base frequency setting.

## ■ L3-11: Overvoltage Suppression Function Selection

Enables or disables the overvoltage suppression function.

No.	Name	Setting Range	Default
L3-11	Overvoltage Suppression Function Selection	0, 1	0

### Setting 0: Disabled

The regenerative torque limit and the output frequency are not adjusted. A regenerative load may trip the drive with an overvoltage fault. Use this setting if dynamic braking options are installed.

### Setting 1: Enabled

When the DC bus voltage rises due to regenerative load, an overvoltage fault is prevented by decreasing the regenerative torque limit and increasing the output frequency.

## ■ L3-17: Target DC Bus Voltage for Overvoltage Suppression and Stall Prevention

Sets the target DC bus voltage level used by the overvoltage suppression function (L3-11 = 1), Intelligent Stall Prevention during deceleration (L3-04 = 2).

No.	Name	Setting Range	Default
L3-17	Target DC Bus Voltage for Overvoltage Suppression and Stall Prevention	300 to 800 Vdc <1>	740 Vdc <1> <2>

<1> Values are specific to 400 V class drives. Multiply the values by 1.4375 for 575 V class drives. Multiply the values by 1.725 for 690 V class drives, but set the value below 1040 Vdc (overvoltage protection level).

<2> This value is initialized when E1-01 is changed.

## ■ L3-27: Stall Prevention Detection Time

Sets a delay time from when the Stall Prevention level is reached and the actual Stall Prevention function is activated.

No.	Name	Setting Range	Default
L3-27	Stall Prevention Detection Time	0 to 5000 ms	50 ms

## ◆ L4: Speed Detection

These parameters set up the speed agree and speed detection functions that can be assigned to the multi-function output terminals.

### ■ L4-01, L4-02: Speed Agreement Detection Level and Detection Width

Parameter L4-01 sets the detection level for the digital output functions Speed agree 1, User-set speed agree 1, Frequency detection 1, and Frequency detection 2.

Parameter L4-02 sets the hysteresis level for these functions.

## 1.8 L: Protection Functions

No.	Name	Setting Range	Default
L4-01	Speed Agreement Detection Level	0.0 to 150.0 Hz	0.0 Hz
L4-02	Speed Agreement Detection Width	0.0 to 20.0 Hz	Determined by A1-02

Refer to H2-01 to H2-03: Terminal M1-M2, M3-M4, and M5-M6 Function Selection on page 104, Settings 2, 3, 4, and 5.

### ■ L4-03, L4-04: Speed Agreement Detection Level and Detection Width (+/-)

Parameter L4-03 sets the detection level for the digital output functions Speed agree 2, User-set speed agree 2, Frequency detection 3, and Frequency detection 4.

Parameter L4-04 sets the hysteresis level for these functions.

No.	Name	Setting Range	Default
L4-03	Speed Agreement Detection Level (+/-)	-150.0 to 150.0 Hz	0.0 Hz
L4-04	Speed Agreement Detection Width (+/-)	0.0 to 20.0 Hz	Determined by A1-02

Refer to H2-01 to H2-03: Terminal M1-M2, M3-M4, and M5-M6 Function Selection on page 104, Settings 13, 14, 15, and 16.

### ■ L4-05: Frequency Reference Loss Detection Selection

The drive can detect a loss of an analog frequency reference from input A1, A2, or A3. Frequency reference loss is detected when the frequency reference drops below 10% of the reference or below 5% of the maximum output frequency within 400 ms.

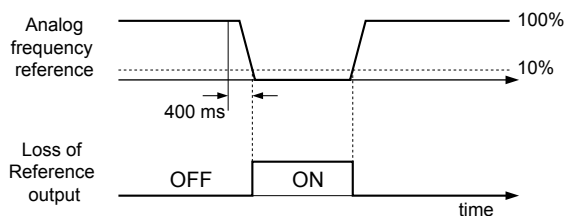

Figure 1.101 Loss of Reference Function

Set H2-01, H2-02, or H2-03 to C for a digital output to trigger when frequency reference loss occurs. Refer to Setting C: Frequency Reference Loss on page 108 for details on setting the output function.

Parameter L4-05 selects the operation when a frequency reference loss is detected.

No.	Name	Setting Range	Default
L4-05	Frequency Reference Loss Detection Selection	0, 1	0

#### Setting 0: Stop

Drive follows the frequency reference (which is no longer present) and stops the motor.

#### Setting 1: Continue operation with reduced frequency reference

The drive will continue operation at the frequency reference value set to parameter L4-06. When the external frequency reference value is restored, the operation is continued with the frequency reference.

### ■ L4-06: Frequency Reference at Reference Loss

Sets the frequency reference level at which the drive runs when L4-05 = 1 and when detecting a reference loss. The value is set as a percentage of the frequency reference before the loss was detected.

No.	Name	Setting Range	Default
L4-06	Frequency Reference at Reference Loss	0.0 to 100.0%	80.0%

### ■ L4-07: Speed Agreement Detection Selection

Determines when frequency detection is active using parameters L4-01 through L4-04.

No.	Name	Setting Range	Default
L4-07	Speed Agreement Detection Selection	0, 1	0



**Setting 0: No Detection during Baseblock****Setting 1: Detection always Enabled****◆ L5: Fault Restart**

After a fault has occurred, Fault Restart attempts to automatically restart the motor and continue operation instead of stopping. The drive can perform a self-diagnostic check and resume the operation after a fault has occurred. If the self-check is successful and the cause of the fault has disappeared, the drive restarts by first performing Speed Search (*Refer to b3: Speed Search on page 27* for details).

- Note:**
1. The wiring sequence should remove the Forward/Reverse command when a fault is triggered and output is shut off.
  2. When the Forward/Reverse command is removed, the drive can perform a self-diagnostic check and attempt to restart the fault automatically.

**WARNING!** *Sudden Movement Hazard. Do not use the fault restart function in lifting applications. Fault restart may cause the machine to drop the load, which could result in death or serious injury.*

The drive can attempt to restart itself following the faults listed below.

Fault	Name	Fault	Name
GF	Ground Fault	oL4	Overtorque 2
LF	Output Open Phase	ov	DC Bus Overvoltage
oC	Overcurrent	PF	Input Phase Loss
oH1	Drive Overheat	rH	Braking Resistor Fault
oL1	Motor Overload	rr	Braking Transistor Fault
oL2	Drive Overload	Uv1	DC Bus Undervoltage </>
oL3	Overtorque 1	STo	Pull-Out Detection

</> When L2-01 is set to 1 through 4 (continue operation during momentary power loss)

Use parameters L5-01 to L5-05 to set up automatic fault restart.

Set H2-01, H2-02, or H2-03 to 1E. to output a signal during fault restart.

**■ L5-01: Number of Auto Restart Attempts**

Sets the number of times that the drive may attempt to restart itself.

Parameter L5-05 determines the method of incrementing the restart counter. When the counter reaches the number set to L5-01, the operation stops and the fault must be manually cleared and reset.

The restart counter is incremented at each restart attempt, regardless of whether the attempt was successful. When the counter reaches the number set to L5-01, the operation stops and the fault must be manually cleared and reset.

The number of fault restarts is reset to zero when:

- The drive operates normally for 10 minutes following a fault restart.
- A fault is cleared manually after protective functions are triggered.
- The power supply is cycled.

No.	Name	Setting Range	Default
L5-01	Number of Auto Restart Attempts	0 to 10 Times	0 Times

**■ L5-02: Auto Restart Fault Output Operation Selection**

Determines if a fault output is triggered (H2-□□ = E) when the drive attempts to restart.

No.	Name	Setting Range	Default
L5-02	Auto Restart Fault Output Operation Selection	0, 1	0

**Setting 0: No Fault Output****Setting 1: Fault Output Is Set****■ L5-04: Fault Reset Interval Time**

Determines the amount of time to wait between restart attempts when parameter L5-05 is set to 1.

## 1.8 L: Protection Functions

No.	Name	Setting Range	Default
L5-04	Fault Reset Interval Time	0.5 to 600.0 s	10.0 s

### ■ L5-05: Fault Reset Operation Selection

No.	Name	Setting Range	Default
L5-05	Fault Reset Operation Selection	0, 1	0

#### Setting 0: Count Successful Restarts

The drive will continuously attempt to restart. If it restarts successfully, the restart counter is increased. This operation is repeated each time a fault occurs until the counter reaches the value set to L5-01.

#### Setting 1: Count Restart Attempts

The drive will attempt to restart using the time interval set to parameter L5-04. A record is kept of the number of attempts to restart to the drive, regardless of whether those attempts were successful. When the number of attempted restarts exceeds the value set to L5-01, the drive stops attempting to restart.

## ◆ L6: Torque Detection

The drive provides two independent torque detection functions that trigger an alarm or fault signal when the load is too heavy (oL), or suddenly drops (UL). These functions are set up using the L6-□□ parameters. Program the digital outputs as shown below to indicate the underload or overload condition to an external device:

**Note:** When overtorque occurs in the application, the drive may stop due to overcurrent (oC) or overload (oL1). To prevent the drive from stopping, use torque detection to indicate an overload situation to the controller before oC or oL1 occur. Use undertorque detection to discover application problems like a torn belt, a pump shutting off, or other similar trouble.

H2-01, H2-02, H2-03 Setting	Description
B	Torque detection 1, N.O. (output closes when overload or underload is detected)
17	Torque detection 1, N.C. (output opens when overload or underload is detected)
18	Torque detection 2, N.O. (output closes when overload or underload is detected)
19	Torque detection 2, N.C. (output opens when overload or underload is detected)

Figure 1.102 and Figure 1.103 illustrate the functions of overtorque and undertorque detection.

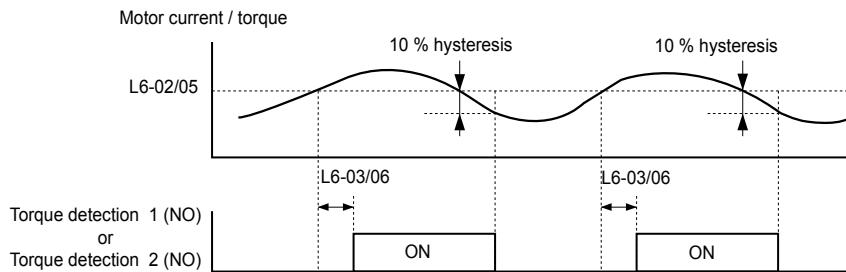

Figure 1.102 Overtorque Detection Operation

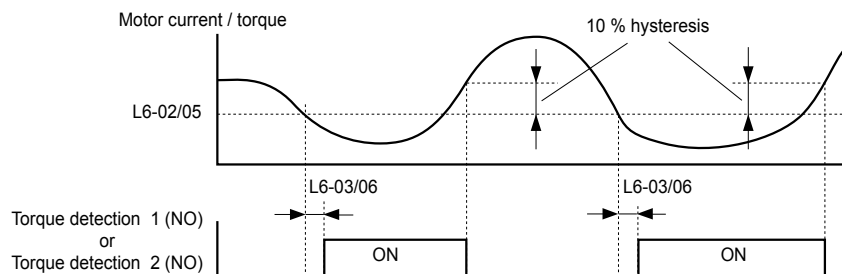

Figure 1.103 Undertorque Detection Operation

- Note:**
1. The torque detection function uses a hysteresis of 10% of the drive rated output current and motor rated torque.
  2. In V/f, V/f w/PG and OLV/PM, the level is set as a percentage of the drive rated output current. In OLV, CLV, AOLV/PM and CLV/PM, the level is set as a percentage of the motor rated torque.

## ■ L6-01, L6-04: Torque Detection Selection 1, 2

The torque detection function is triggered when the current or torque exceed the levels set to L6-02 and L6-05 for longer than the times set to L6-03 and L6-06. L6-01 and L6-04 select the conditions for detection and the operation that follows.

No.	Name	Setting Range	Default
L6-01	Torque Detection Selection 1	0 to 8	0
L6-04	Torque Detection Selection 2	0 to 8	0

### Setting 0: Disabled

#### Setting 1: oL3, oL4 at speed agree (Alarm)

Overtorque detection is active only when the output speed is equal to the frequency reference (i.e., no detection during acceleration and deceleration). The operation continues after detecting overtorque and triggering an oL3/oL4 alarm.

#### Setting 2: oL3, oL4 at run (Alarm)

Overtorque detection works as long as the Run command is active. The operation continues after detecting overtorque and triggering an oL3/oL4 alarm.

#### Setting 3: oL3, oL4 at speed agree (Fault)

Overtorque detection is active only when the output speed is equal to the frequency reference, i.e., no detection during acceleration and deceleration. The operation stops and triggers an oL3/oL4 fault.

#### Setting 4: oL3, oL4 at run (Fault)

Overtorque detection works as long as a Run command is active. The operation stops and triggers an oL3/oL4 fault.

#### Setting 5: UL3, UL4 at speed agree (Alarm)

Undertorque detection is active only when the output speed is equal to the frequency reference, i.e., no detection during acceleration and deceleration. The operation continues after detecting overtorque and triggering a UL3/UL4 alarm.

#### Setting 6: UL3, UL4 at Run (Alarm)

Undertorque detection works as long as the Run command is active. The operation continues after detecting overtorque and triggering a UL3/UL4 alarm.

#### Setting 7: UL3, UL4 at Speed Agree (Fault)

Undertorque detection is active only when the output speed is equal to the frequency reference, i.e., no detection during acceleration and deceleration. The operation stops and triggers a UL3/UL4 fault.

#### Setting 8: UL3, UL4 at run (Fault)

Undertorque detection works as long as a Run command is active. The operation stops and triggers a UL3/UL4 fault.

## ■ L6-02, L6-05: Torque Detection Level 1, 2

These parameters set the detection levels for torque detection functions 1 and 2. In V/f and OLV/PM control modes, these levels are set as a percentage of the drive rated output current. In vector control modes, these levels are set as a percentage of the motor rated torque.

No.	Name	Setting Range	Default
L6-02	Torque Detection Level 1	0 to 300%	150%
L6-05	Torque Detection Level 2	0 to 300%	150%

**Note:** The torque detection level 1 (L6-02) can also be supplied by an analog input terminal set to H3-□□ = 7. Here, the analog value has priority and the setting in L6-02 is disregarded. Torque detection level 2 (L6-05) cannot be set by an analog input.

## ■ L6-03, L6-06: Torque Detection Time 1, 2

These parameters determine the time required to trigger an alarm or fault after exceeding the levels in L6-02 and L6-05.

No.	Name	Setting Range	Default
L6-03	Torque Detection Time 1	0.0 to 10.0 s	0.1 s
L6-06	Torque Detection Time 2	0.0 to 10.0 s	0.1 s

## ■ Mechanical Weakening Detection

This function detects the mechanical weakening of a machine that leads to overtorque or undertorque situations after a set machine operation time has elapsed.

## 1.8 L: Protection Functions

The function is activated in the drive when the cumulative operation counter U4-01 exceeds the time set to parameter L6-11. Mechanical Weakening Detection uses the torque detection 1 settings (L6-01, L6-02, L6-03) and triggers an oL5 fault when overtorque or undertorque occurs in the speed range determined by parameter L6-08 and L6-09. The oL5 operation is set by parameter L6-08.

Set H2-□□ to 22 to output a signal for Mechanical Weakening Detection.

### ■ L6-08: Mechanical Weakening Detection Operation

Sets the speed range to detect mechanical weakening and the action to take when mechanical weakening is detected.

No.	Name	Setting Range	Default
L6-08	Mechanical Weakening Detection Operation	0 to 8	0

#### Setting 0: Disabled

#### Setting 1: Continue running if the speed is greater than L6-09 (Signed) (Alarm)

Detection when the speed is above L6-09 (signed). Operation continues and triggers an oL5 alarm after detection.

#### Setting 2: Continue running if the speed is greater than L6-09 (Alarm)

Detection when the speed is above L6-09 (unsigned). Operation continues and triggers an oL5 alarm after detection.

#### Setting 3: Stop when motor speed is greater than L6-09 (Signed)

Detection when the speed is above L6-09 (signed). Operation stops and triggers an oL5 fault after detection.

#### Setting 4: Stop when Motor Speed is Greater than L6-09

Detection when the speed is above L6-09 (unsigned). Operation stops and triggers an oL5 fault after detection.

#### Setting 5: Continue running if the speed is less than L6-09 (Signed) (Alarm)

Detection when the speed is below L6-09 (signed). Operation continues and triggers an oL5 alarm after detection.

#### Setting 6: Continue running if the speed is less than L6-09 (Alarm)

Detection when the speed is below L6-09 (unsigned). Operation continues and triggers an oL5 alarm after detection.

#### Setting 7: Stop when Motor Speed is less than L6-09 (Signed)

Detection when the speed is below L6-09 (signed). Operation stops and triggers an oL5 fault after detection.

#### Setting 8: Stop when motor speed is less than L6-09

Detection when the speed is below L6-09 (unsigned). Operation stops and triggers an oL5 fault after detection.

### ■ L6-09: Mechanical Weakening Detection Speed Level

Sets the speed level for Mechanical Weakening Detection as a percentage of the maximum frequency. If L6-08 is set for unsigned speed detection (L6-08 = 2, 4, 6, 8), the absolute value of L6-09 is used (negative settings are treated as positive values).

No.	Name	Setting Range	Default
L6-09	Mechanical Weakening Detection Speed Level	-110.0 to 110.0%	110%

### ■ L6-10: Mechanical Weakening Detection Time

Sets the time permitted for the situation selected in parameter L6-08 to arise before detecting mechanical weakening.

No.	Name	Setting Range	Default
L6-10	Mechanical Weakening Detection Time	0.0 to 10.0 s	0.1 s

### ■ L6-11: Mechanical Weakening Detection Start Time

Sets the cumulative drive operation time at which Mechanical Weakening Detection is activated. The function activates when U4-01 reaches the L6-11 value.

No.	Name	Setting Range	Default
L6-11	Mechanical Weakening Detection Start Time	0 to 65535 h	0 h

## ◆ L7: Torque Limit

The torque limit function limits the torque in each of the four quadrants individually to protect machinery in OLV, CLV, AOLV/PM, and CLV/PM control modes. Set the limit through parameters, analog inputs, or by switching a digital output programmed for “During torque limit” (H2-01, H2-02, H2-03 = 30) when the drive is operating at the torque limit.

### ■ Setting Torque Limits

Parameters L7-01 to L7-04 define the torque limits for each of the four operation quadrants. It is also possible to use Analog inputs to define a general limit for all operation conditions (H3-02, H3-06, H3-10 = 15) or to set separate limits for each operation condition (H3-02, H3-06, H3-10 = 10, 11, or 12). **Figure 1.104** shows limit setting is applied in each quadrant.

If two limit values are defined for the same operation conditions, the drive will use the lower value.

**Note:** The maximum output torque is ultimately limited by the drive output current (max. 150% of drive rated current in HD, 120% in ND). Output torque will not exceed the drive rated current limit even if the torque limits are set to higher values.

Example: If parameter L7-01 = 130%, L7-02 to L7-04 = 200%, and an analog input sets a general torque limit of 150% (H3-02, H3-06, H3-10 = 15), then the torque limit will be 130% in quadrant 1, but 150% in the other quadrants.

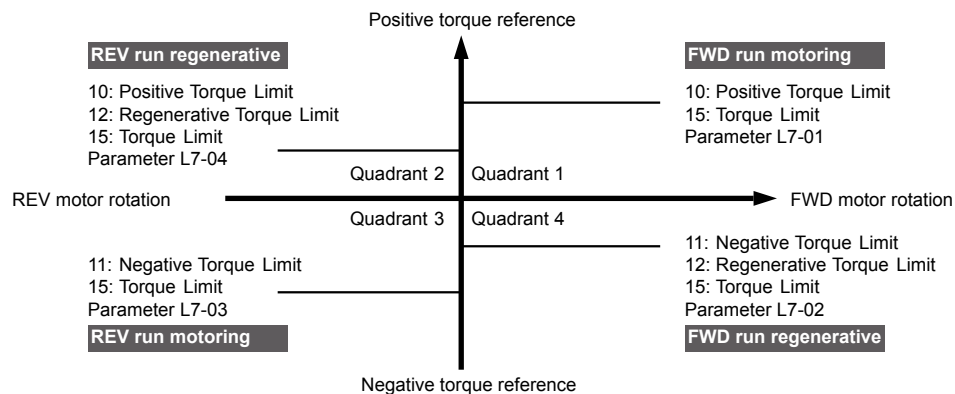

Figure 1.104 Torque Limit Parameters and Analog Input Settings

### ■ L7-01 to L7-04: Torque Limits

These parameters set the torque limits in each operation mode.

No.	Name	Setting Range	Default
L7-01	Forward Torque Limit	0 to 300%	200%
L7-02	Reverse Torque Limit	0 to 300%	200%
L7-03	Forward Regenerative Torque Limit	0 to 300%	200%
L7-04	Reverse Regenerative Torque Limit	0 to 300%	200%

**Note:** If the multi-function analog input is programmed for “10: Forward torque limit”, “11: Reverse torque limit”, “12: Regenerative torque limit”, or “15: General torque limit”, the drive uses the lowest value from L7-01 through L7-04, or analog input torque limit.

### ■ L7-06: Torque Limit Integral Time Constant

Sets the integral time constant for the torque limit function. Decrease the setting for faster torque limit response. Increase the setting if oscillation occurs when operating at the torque limit.

No.	Name	Setting Range	Default
L7-06	Torque Limit Integral Time Constant	5 to 10000 ms	200 ms

### ■ L7-07: Torque Limit Control Method Selection during Accel/Decel

Selects the function of torque limit during acceleration and deceleration.

No.	Name	Setting Range	Default
L7-07	Torque Limit Control Method Selection during Accel/Decel	0, 1	0

## 1.8 L: Protection Functions

### Setting 0: Proportional control

The torque limit function works with P control during accel and decel, and switches to I control at constant speed. Use this setting when accelerating or decelerating to the desired speed has priority over the torque limit during speed changes.

### Setting 1: Integral control

The torque limit function always uses I control. Use this setting when a highly accurate torque limit is required, even during speed changes. Using this function may increase the acceleration time, or prevent the motor speed from reaching the frequency reference if the torque limit is reached first.

### ■ L7-16: Torque Limit Process at Start

Assigns a time filter to allow the torque limit to build at start.

No.	Name	Setting Range	Default
L7-16	Torque Limit Process at Start	0, 1	1

#### Setting 0: Disabled

Torque limit is created at start without a delay time. Disable L7-16 to maximize the response time when the application requires sudden acceleration or deceleration at start.

#### Setting 1: Enabled

A delay time of 64 ms is added to allow the torque limit to build at start.

### ■ L7-30: Regenerative Torque Limit Mode Selection

Special function of regenerative Torque limit for Omron (same as G5HHP).

No.	Name	Setting Range	Default
L7-30	Regenerative Torque Limit Mode Selection	0, 1	0

#### Setting 0: Standard mode

Torque limit from all analogs and communications effective.

#### Setting 1: Independent mode

Only L7-03, L7-04, and H3-□□ = 12H (regenerative torque limit) are effective.

## ◆ L8: Drive Protection

### ■ L8-02: Overheat Alarm Level

Sets the overheat alarm (oH) detection level.

The drive outputs an alarm when the heatsink temperature exceeds the overheat alarm level. If the drive is set to continue operation after this alarm occurs (L8-03 = 4) and the temperature reaches the overheat fault level, the drive will trigger an oH1 fault and stop operation.

When an output terminal is set for the oH pre-alarm (H2-□□ = 20), the switch will close when the heatsink temperature rises above L8-02.

No.	Name	Setting Range	Default
L8-02	Overheat Alarm Level	50 to 150 °C	Determined by C6-01 and o2-04

### ■ L8-03: Overheat Pre-Alarm Operation Selection

Sets the operation when an overheat pre-alarm is detected.

**Note:** Change L8-03 setting only when necessary.

No.	Name	Setting Range	Default
L8-03	Overheat Pre-Alarm Operation Selection	0 to 4	3

#### Setting 0: Ramp to stop

If an overheat alarm occurs, the drive decelerates to stop using the currently selected deceleration time. If a digital output is programmed for “fault” (H2-□□ = E), this output will be triggered.

**Setting 1: Coast to stop**

If an overheat alarm occurs, the drive switches off the output and the motor coasts to stop. If a digital output is programmed for “fault” (H2-□□ = E), this output will be triggered.

**Setting 2: Fast Stop**

If an overheat alarm occurs, the drive decelerates to stop using the Fast Stop time (C1-09). If a digital output is programmed for “fault” (H2-□□ = E), this output will be triggered.

**Setting 3: Alarm only**

If an overheat alarm occurs, an alarm is output and the drive continues operation.

**Setting 4: Operation with reduced speed**

If an overheat alarm occurs, the operation continues with the speed reduced to the level set to parameter L8-19. If the oH alarm is still present after 10 s, the speed is reduced again. The amount of speed reduction depends on how often the alarm repeats. If the oH alarm disappears while the drive is operating at a reduced speed, the drive will switch to the previous speed in 10 s increments until reaching base frequency. *Figure 1.105* explains the operation with reduced speed during an oH alarm. A digital output programmed for 4D is switched when the oH alarm is still active after ten reduction cycles.

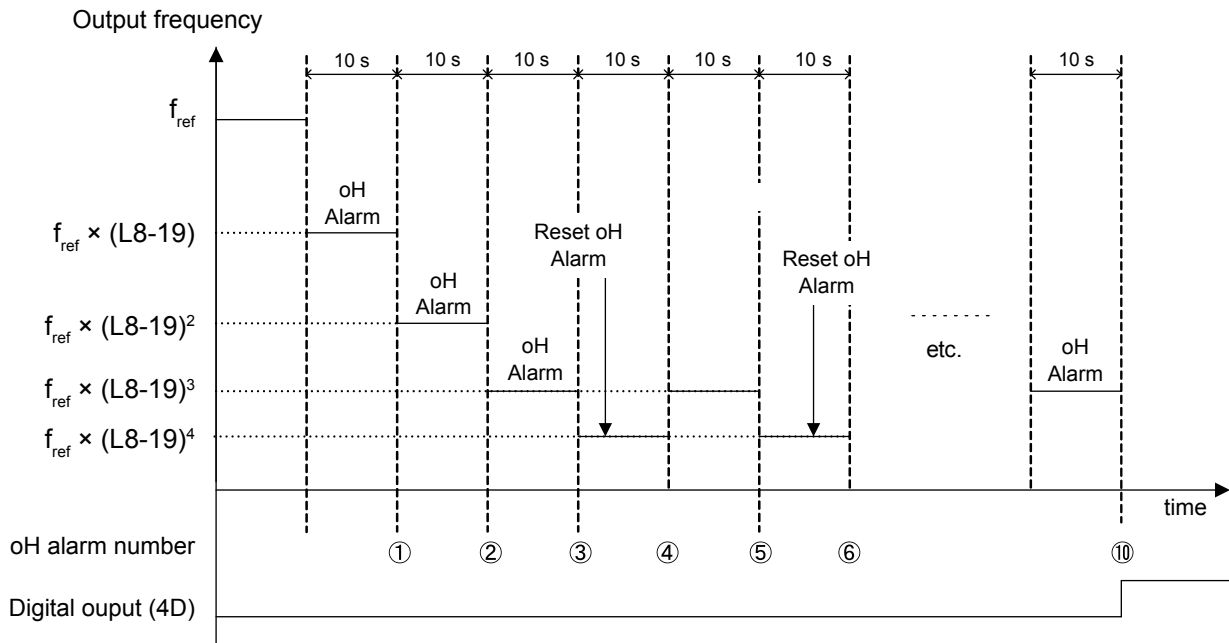

Figure 1.105 Output Frequency Reduction During Overheat Alarm

**■ L8-19: Frequency Reduction Rate during Overheat Pre-Alarm**

Specifies the output frequency reduction when L8-03 is set to 4 and an oH alarm is present. Set as a factor of the maximum output frequency.

No.	Name	Setting Range	Default
L8-19	Frequency Reduction Rate During Overheat Pre-Alarm	0.1 to 0.9	0.8

**■ L8-05: Input Phase Loss Protection Selection**

Enables or disables the input phase loss detection.

No.	Name	Setting Range	Default
L8-05	Input Phase Loss Protection Selection	0, 1	1

**Setting 0: Disabled**

**Setting 1: Enabled**

Enables input phase loss detection. Since measuring the DC bus ripple detects input phase loss, a power supply voltage imbalance or main circuit capacitor deterioration may also trigger a phase loss fault (PF).

Detection is disabled if:

- The drive is decelerating.

## 1.8 L: Protection Functions

- No Run command is active.
- Output current is less than or equal to 30% of the drive rated current.

### ■ L8-07: Output Phase Loss Protection Selection

Enables or disables the output phase loss detection triggered when the output current falls below 5% of the drive rated current.

- Note:**
1. Output phase loss detection can mistakenly be triggered if the motor rated current is very small compared to the drive rating. Disable this parameter in such cases.
  2. Output phase loss detection is not possible when the drive is running a PM motor with light load.

No.	Name	Setting Range	Default
L8-07	Output Phase Loss Protection Selection	0 to 2	1

#### Setting 0: Disabled

#### Setting 1: Fault when One Phase Is Lost

An output phase loss fault (LF) is triggered when one output phase is lost. The output shuts off and the motor coasts to stop.

#### Setting 2: Fault when Two Phases Are Lost

An output phase loss fault (LF) is triggered when two output phases are lost. The output shuts off and the motor coasts to stop.

### ■ L8-09: Output Ground Fault Detection Selection

Enables or disables the output ground fault detection.

No.	Name	Setting Range	Default
L8-09	Output Ground Fault Detection Selection	0, 1	1

#### Setting 0: Disabled

Ground faults are not detected.

#### Setting 1: Enabled

A ground fault (GF) is triggered when high leakage current or a ground short circuit occurs in one or two output phases.

### ■ L8-10: Heatsink Cooling Fan Operation Selection

Selects the heatsink cooling fan operation.

No.	Name	Setting Range	Default
L8-10	Heatsink Cooling Fan Operation Selection	0, 1	0

#### Setting 0: Run with timer

The fan is switched on when a Run command is active and switched off with the delay set to parameter L8-11 after releasing the Run command. This setting extends the fan lifetime.

#### Setting 1: Run always

The fan runs when power is supplied to the drive.

### ■ L8-11: Heatsink Cooling Fan Off-Delay Time

Sets the cooling fan switch off-delay time if parameter L8-10 is set to 0.

No.	Name	Setting Range	Default
L8-11	Heatsink Cooling Fan Off-Delay Time	0 to 300 s	60 s

### ■ L8-12: Ambient Temperature Setting

Automatically adapts the drive rated current to safe values when used with parameter L8-35. This eliminates the need to reduce the drive rated current when the temperature where the drive is mounted is above the specified values.

No.	Name	Setting Range	Default
L8-12	Ambient Temperature Setting	-10 to 50 °C	40 °C



### ■ L8-15: oL2 Characteristics Selection at Low Speeds

Selects whether the drive overload capability (oL fault detection level) is reduced at low speeds to prevent premature output transistor failures.

**Note:** Contact Yaskawa for consultation before disabling this function. Disabling this function may shorten the operating life of the power transistors.

No.	Name	Setting Range	Default
L8-15	oL2 Characteristics Selection at Low Speed	0, 1	1

#### Setting 0: Protection Disabled at Low Speed

The overload protection level is not reduced. Frequently operating the drive with high output current at low speed can lead to premature drive faults.

#### Setting 1: Protection Enabled at Low Speed

The overload protection level (oL2 fault detection level) is automatically reduced at speeds below 6 Hz. At zero speed, the overload is derated by 50%.

### ■ L8-18: Software Current Limit Selection

Enables or disables the Software Current Limit (CLA) protection function to prevent main circuit transistor failures caused by high current.

**Note:** Do not change this setting unless absolutely necessary. Leave the Software CLA enabled for proper drive protection and operation.

No.	Name	Setting Range	Default
L8-18	Software Current Limit Selection	0, 1	0

#### Setting 0: Software CLA Disabled

The drive may trip on an oC fault if the load is too heavy or the acceleration is too short.

#### Setting 1: Software CLA Enabled

When the Software CLA current level is reached, the drive reduces the output voltage to reduce the current. Normal operation continues when the current level drops below the Software CLA level.

### ■ L8-32: Main Contactor and Cooling Fan Power Supply Failure Selection

Determines drive operation when a FAn fault occurs.

No.	Name	Setting Range	Default
L8-32	Main Contactor and Cooling Fan Power Supply Failure Selection	0 to 4	1

#### Setting 0: Ramp to stop

The drive stops the motor using the deceleration time set in parameter C1-02.

#### Setting 1: Coast to stop

The drive output is switched off and the motor coasts to a stop.

#### Setting 2: Fast stop

The drive stops the motor using the Fast stop time set in parameter C1-09.

#### Setting 3: Alarm only

The operation is continued and a FAn alarm is displayed on the digital operator.

#### Setting 4: Operation with reduced speed

The operation is continued, but the speed is reduced to the level set in parameter L8-19.

**Note:** “FAn” is detected as an error when Settings 0 or 2 are selected; it is detected as an alarm when Settings 3 or 4 are selected.

### ■ L8-38: Carrier Frequency Reduction Selection

Selects the operation of the carrier frequency reduction function. Reduces the carrier frequency when the output current exceeds a certain level. This temporarily increases the overload capability (oL2 detection), allowing the drive to run through transient load peaks without tripping.

**Note:** This function cannot be used in AOLV/PM.

## 1.8 L: Protection Functions

No.	Name	Setting Range	Default
L8-38	Carrier Frequency Reduction Selection	0 to 2	Determined by A1-02, C6-01 and o2-04

### Setting 0: Disabled

No carrier frequency reduction at high current.

### Setting 1: Enabled for output frequencies below 6 Hz

The carrier frequency is reduced at speeds below 6 Hz when the current exceeds 100% of the drive rated current. The drive returns to the normal carrier frequency when the current falls below 88% or the output frequency exceeds 7 Hz.

### Setting 2: Enabled for entire frequency range

The carrier frequency is reduced at the following speeds:

- Below 6 Hz when the current exceeds 100% of the drive rated current.
- Above 7 Hz when the current exceeds 112% of the drive rated current.

The drive uses the delay time set in parameter L8-40 and a hysteresis of 12% when switching the carrier frequency back to the set value.

### ■ L8-40: Carrier Frequency Reduction Off-Delay Time

Sets a hold time before returning to the original carrier frequency setting after the carrier frequency has been temporarily derated as determined by L8-38. The carrier frequency reduction function is disabled when this value is 0.00 s.

No.	Name	Setting Range	Default
L8-40	Carrier Frequency Reduction Off-Delay Time	0.00 to 2.00 s	Determined by A1-02

### ■ L8-41: High Current Alarm Selection

Triggers a high current alarm (HCA) when the output current exceeds 150% of the drive rated current.

No.	Name	Setting Range	Default
L8-41	High Current Alarm Selection	0, 1	0

### Setting 0: Disabled

No alarm is detected.

### Setting 1: Enabled

An alarm is triggered when the output current exceeds 150% of the drive rated current. A digital output set for an alarm (H2-□□ = 10) will close.

### ■ L8-78: Power Unit Output Phase Loss Protection

Protects the power unit from phase loss.

**Note:** This parameter is only available in models CIMR-A□4A0930, 4A1200 and A1000 HHP.

No.	Name	Setting Range	Default
L8-78	Power Unit Output Phase Loss Protection	0, 1	1

### Setting 0: Disabled

### Setting 1: Enabled

### ■ L8-86: Detection Selection when Panel Fan Fails

Detects the loss of the drive panel fan by the panel fan input.

**Note:** Settings 3 or 4 reduce inverter O/L level from 100% to 80%

No.	Name	Setting Range	Default
L8-86	Detection selection when Panel Fan Fails	0 to 5	1

**Setting 0: Ramp Stop (Fault)**

**Setting 1: Coast Stop (Fault)**

**Setting 2: Fast Stop (Fault)**

**Setting 3: Continue Running (Alarm)**

**Setting 4: Continue Running at L8-19 Speed**

**Setting 5: Disabled**

### ■ L8-87: Detection Selection when Diode Converter Fans Fail

Detects the loss of the Diode Converter fans by the fan control input.

**Note:** Settings 3 or 4 reduce drive O/L level from 100% to 80%

No.	Name	Setting Range	Default
L8-87	Detection Selection when Diode Converter Fans Fail	0 to 5	1

**Setting 0: Ramp Stop (Fault)**

**Setting 1: Coast Stop (Fault)**

**Setting 2: Fast Stop (Fault)**

**Setting 3: Continue Running (Alarm)**

**Setting 4: Continue Running at L8-19 Speed**

**Setting 5: Disabled**

## 1.9 n: Special Adjustments

These parameters control a variety of specialized adjustments and functions, including Hunting Prevention, AFR Control, High Slip Braking and resistance between motor lines.

### ◆ n1: Hunting Prevention

Hunting Prevention prevents the drive from hunting as a result of low inertia and operating with light load. Hunting often occurs with a high carrier frequency and an output frequency below 30 Hz.

#### ■ n1-01: Hunting Prevention Selection

Enables or disables the Hunting Prevention function.

**Note:** This function is available only when using V/f Control. Disable Hunting Prevention when drive response is more important than suppressing motor oscillation. This function may be disabled without problems in applications with high inertia loads or relatively heavy loads.

No.	Name	Setting Range	Default
n1-01	Hunting Prevention Selection	0, 1	1

**Setting 0: Disabled**

**Setting 1: Enabled**

#### ■ n1-02: Hunting Prevention Gain Setting

Sets the gain for the Hunting Prevention Function.

No.	Name	Setting Range	Default
n1-02	Hunting Prevention Gain Setting	0.00 to 2.50	1.00

Although this parameter rarely needs to be changed, it may require adjustment in the following situations:

- If the motor vibrates while lightly loaded and n1-01 = 1, increase the gain by 0.1 until vibration ceases.
- If the motor stalls while n1-01 = 1, decrease the gain by 0.1 until the stalling ceases.

#### ■ n1-03: Hunting Prevention Time Constant

Determines the responsiveness of the Hunting Prevention function (affects the primary delay time for Hunting Prevention).

No.	Name	Setting Range	Default
n1-03	Hunting Prevention Time Constant	0 to 500 ms	Determined by o2-04

Although this parameter rarely needs to be changed, it may require adjustment in the following situations:

- Increase this value for applications with a large load inertia. A higher setting leads to slower response, which can result in oscillation at lower frequencies.
- Lower this setting if oscillation occurs at low speed.

#### ■ n1-05: Hunting Prevention Gain while in Reverse

This parameter functions the same as n1-02, except it is used when rotating in reverse. See the explanation for n1-02.

**Note:** n1-02 is enabled for forward and reverse operation when n1-05 = 0.0 ms.

No.	Name	Setting Range	Default
n1-05	Hunting Prevention Gain while in Reverse	0.00 to 2.50	0.00

### ◆ n2: Speed Feedback Detection Control (AFR) Tuning

These parameters help achieve speed stability when a load is suddenly applied or removed.

**Note:** Properly set all motor parameters or perform Auto-Tuning before making changes to the AFR parameters.

#### ■ n2-01: AFR Gain

Sets the internal speed feedback detection control gain in the AFR.

No.	Name	Setting Range	Default
n2-01	AFR Gain	0.00 to 10.00	1.00

Although this parameter rarely needs to be changed, it may require adjustment in the following situations:

- If hunting occurs, increase the setting value in steps of 0.05 while checking the response.
- If response is low, decrease the setting value in steps of 0.05 while checking the response.

### ■ n2-02, n2-03: AFR Time Constant 1, 2

Parameter n2-02 sets the time constant normally used by AFR.

Parameter n2-03 sets the time constant during Speed Search or regenerative operation.

No.	Name	Setting Range	Default
n2-02	AFR Time Constant 1	0 to 2000 ms	50 ms
n2-03	AFR Time Constant 2	0 to 2000 ms	750 ms

**Note:** Setting parameter n2-02 higher than n2-03 will trigger an oPE08 error.

Although these parameters rarely need to be changed, they may require adjustment in the following situations:

- If hunting occurs, increase n2-02. If response is low, decrease it.
- Increase n2-03 if overvoltage occurs with high inertia loads at the end of acceleration or with sudden load changes.
- If setting n2-02 to a higher value, increase C4-02 (Torque Compensation Delay Time Constant 1) proportionally.
- If setting n2-03 to a higher value, increase C4-06 (Torque Compensation Delay Time Constant 2) proportionally.

## ◆ n3: High Slip Braking (HSB) and Overexcitation Braking

### ■ High Slip Braking (V/f)

HSB works in V/f Control only and decreases the stopping time compared to normal deceleration without using dynamic braking options. HSB reduces the output frequency in large steps to stop the motor and produce a high slip, which dissipates the regenerative energy created from decelerating the load in the motor windings. Due to the increased temperature of the motor windings, do not use HSB to frequently stop the motor. The duty cycle should be around 5% or lower.

#### Notes on using High Slip Braking

- The set deceleration time is ignored during HSB. Use Overexcitation Deceleration 1 (L3-04 = 4) or a dynamic braking option to stop the motor within a specified time.
- Braking time varies based on the load inertia and motor characteristics.
- Enabling HSB and KEB Ride-Thru simultaneously will trigger an oPE03 error.
- HSB must be triggered by a digital input set to H1-□□ = 68. After the HSB command is given, the drive will not restart until the motor is completely stopped and the Run command is cycled.
- Use parameters n3-01 through n3-04 to adjust HSB.

### ■ Overexcitation Deceleration (Induction Motors)

Increases the flux during deceleration and allows shorter deceleration time settings without the use of a braking resistor. Enabled by setting L3-04 to 4 or 5. [Refer to L3-04: Stall Prevention Selection during Deceleration on page 141.](#)

#### Notes on Overexcitation Deceleration

- Frequently applying Overexcitation Deceleration raises the motor temperature because regenerative energy is mainly dissipated as heat in the motor. In cases where frequent application is required, make sure the motor temperature does not exceed the maximum allowable value or consider using a braking resistor option in lieu of Overexcitation Deceleration.
- During Overexcitation Deceleration 2, Hunting Prevention in V/f Control and torque limits in OLV Control are disabled.
- Do not use Overexcitation Deceleration in combination with a braking resistor option.
- Overexcitation Deceleration can be used in OLV and CLV, but it lowers the accuracy of Torque Control and braking efficiency. It can be most efficiently used in a V/f Control.
- Overexcitation Deceleration cannot be used with PM motors.

#### Parameter Adjustments

- Use parameters n3-13 through n3-23 to adjust Overexcitation Deceleration.
- When repetitive or long Overexcitation Deceleration causes motor overheat, lower the overexcitation gain (n3-13) and reduce the overslip suppression current level (n3-21).

## 1.9 n: Special Adjustments

- During Overexcitation Deceleration 1 (L3-04 = 4), the drive decelerates at the active deceleration time (C1-02, C1-04, C1-06, or C1-08). Set this time so no overvoltage (ov) fault occurs.
- During Overexcitation Deceleration 2 (L3-04 = 5), the drive decelerates using the active deceleration time while adjusting the deceleration rate to keep the DC bus voltage at the level set to L3-17. The actual stopping time will be longer or shorter than the set deceleration time depending on the motor characteristics and the load inertia. Increase the deceleration time if overvoltage occurs (ov).
- Entering a Run command during Overexcitation Deceleration cancels overexcitation operation and the drive reaccelerates to the specified speed.

### ■ n3-13: Overexcitation Deceleration Gain

Multiplies a gain to the V/f pattern output value during Overexcitation Deceleration to determine the level of overexcitation. The drive returns to the normal V/f value after the motor has stopped or when it is accelerating to the frequency reference.

No.	Name	Setting Range	Default
n3-13	Overexcitation Deceleration Gain	1.00 to 1.40	1.10

The optimum setting for n3-13 depends on the motor flux saturation characteristics.

- Gradually increase the gain to 1.25 to 1.30 to improve the braking power of Overexcitation Deceleration.
- Lower n3-13 when flux saturation characteristics cause overcurrent. A high setting sometimes causes overcurrent (oC), motor overload (oL1), or drive overload (oL2). Lowering n3-21 can also help remedy these problems.

### ■ n3-21: High Slip Suppression Current Level

If the motor current exceeds the value set to n3-21 during Overexcitation Deceleration due to flux saturation, the drive automatically reduces the overexcitation gain. Parameter n3-21 is set as a percentage of the drive rated current.

Set this parameter to a relatively low value to optimize deceleration. If overcurrent, oL1, or oL2 occur during Overexcitation Deceleration, reduce the high slip suppression current level.

No.	Name	Setting Range	Default
n3-21	High Slip Suppression Current Level	0 to 150%	100%

### ■ n3-23: Overexcitation Operation Selection

Limits the Overexcitation Deceleration operation selected in parameter L3-04 to forward only or reverse only.

No.	Name	Setting Range	Default
n3-23	Overexcitation Operation Selection	0 to 2	0

**Setting 0: Overexcitation Operation as Selected in L3-04 in Forward and Reverse Direction**

**Setting 1: Overexcitation Operation as Selected in L3-04 in Forward Direction Only**

**Setting 2: Overexcitation Operation as Selected in L3-04 in Reverse Direction Only**

## 1.10 o: Operator Related Settings

These parameters control the various functions, features, and display of the digital operator.

### ◆ o1: Digital Operator Display Selection

These parameters determine the data display on the digital operator.

#### ■ o1-01: Drive Mode Unit Monitor Selection

The frequency reference display appears when the drive is powered up. Pressing the up arrow key will display the following data: frequency reference → rotational direction → output frequency → output current → o1-01 selection.

Parameter o1-01 selects the content of the last monitor in this sequence.

No.	Name	Setting Range	Default
o1-01	Drive Mode Unit Monitor Selection	104 to 813 U1-04 (Control Mode) to U8-13 (DWEZ Custom Monitor 3) </>	106 (U1-06)

<1> U2-□□ and U3-□□ parameters cannot be selected.

#### ■ o1-02: User Monitor Selection after Power Up

Selects which monitor parameter is displayed upon power up by entering the 1- □□ part of U1-□□. Certain monitors are not available in some control modes. *Refer to U: Monitor Parameters on page 169* for a list of monitors.

No.	Name	Setting Range	Default
o1-02	User Monitor Selection after Power Up	1 to 5	1

**Setting 1: Frequency reference (U1-01)**

**Setting 2: Motor direction**

**Setting 3: Output frequency (U1-02)**

**Setting 4: Output current (U1-03)**

**Setting 5: User-selected monitor (set by o1-01)**

#### ■ o1-03: Digital Operator Display Selection

Sets the units used to display the frequency reference and output frequency. Set o1-03 to 3 for user-set units before setting parameters o1-10 and o1-11.

No.	Name	Setting Range	Default
o1-03	Digital Operator Display Selection	0 to 3	Determined by A1-02

**Setting 0: 0.01 Hz units**

**Setting 1: 0.01% units (100% = max. output frequency)**

**Setting 2: r/min units (calculated by the max output frequency and the no. of motor poles)**

**Setting 3: User-set units (use o1-10, o1-11)**

Set the value used for the maximum frequency reference to o1-10. Set the placement of the decimal point in this number to o1-11.

For example, to have the maximum output frequency displayed as “100.00”, set o1-10 = 1000 and o1-11 = 2 (i.e., 1000 with 2 decimal points).

- Note:**
- Parameter o1-03 allows the programmer to change the units used in the following parameters and monitors:
    - U1-01: frequency reference
    - U1-02: output frequency
    - U1-05: motor speed
    - U1-16: output frequency after softstarter (accel/decel ramp generator)

## 1.10 o: Operator Related Settings

d1-01 to d1-17: frequency references

- Setting o1-03 to 2 requires entering the number of motor poles to E2-04, E4-04, and E5-04.

### ■ o1-04: V/f Pattern Display Unit

**Note:** PM motor control modes are not available in A1000 HHP drive models.

Determines the units used for the frequency reference when setting parameters that create the V/f pattern: E1-04, E1-06, E1-09, E1-11, and E2-04. For motor 2, this includes parameters E3-04, E3-06, E3-07, E3-09, and E3-11. Enabled only in vector control modes (CLV, AOLV/PM, CLV/PM).

No.	Name	Setting Range	Default
o1-04	V/f Pattern Display Unit	0, 1	0

**Setting 0: Hertz**

**Setting 1: r/min**

**Note:** For motor 2, o1-04 can only be set to 0 for Hertz.

### ■ o1-10: User-Set Display Units Maximum Value

Determines the display value that is equal to the maximum output frequency.

No.	Name	Setting Range	Default
o1-10	User-Set Display Units Maximum Value	1 to 60000	Determined by o1-03

### ■ o1-11: User-Set Display Units Decimal Display

Determines how many decimal points should be used to set and display the frequency reference.

No.	Name	Setting Range	Default
o1-11	User-Set Display Units Decimal Display	0 to 3	Determined by o1-03

**Setting 0: No Decimal Point**

**Setting 1: One Decimal Point**

**Setting 2: Two Decimal Points**

**Setting 3: Three Decimal Points**

## ◆ o2: Digital Operator Keypad Functions

These parameters determine the functions assigned to the operator keys.

### ■ o2-01: LO/RE (LOCAL/REMOTE) Key Function Selection

Determines whether the LO/RE key on the digital operator will be enabled for switching between LOCAL and REMOTE.

No.	Name	Setting Range	Default
o2-01	LO/RE Key Function Selection	0, 1	1

**Setting 0: Disabled**

The LO/RE key is disabled.

**Setting 1: Enabled**

The LO/RE switches between LOCAL and REMOTE operation. Switching is possible during stop only. When LOCAL is selected, the LED indicator on the LO/RE key will light up.

**WARNING! Sudden Movement Hazard.** The drive may start unexpectedly if the Run command is already applied when switching from LOCAL mode to REMOTE mode when b1-07 = 1, resulting in death or serious injury. Check all mechanical or electrical connections thoroughly before making any setting changes to o2-01 and b1-07. [Table 1.42](#) lists the setting combinations for o2-01 and b1-07.

**Table 1.42 LO/RE Key and b1-07**

o2-01	b1-07	Switch from LOCAL to REMOTE	Switch from REMOTE to LOCAL
0	0	Not possible	Not possible
	1	Not possible	Not possible



o2-01	b1-07	Switch from LOCAL to REMOTE	Switch from REMOTE to LOCAL
1	0	Will not run until a new Run command is entered.	Run not possible
	1	If a Run command is entered, the drive will start running as soon as the LO/RE key is pushed to change from LOCAL to REMOTE.	Run not possible

■ **o2-02: STOP Key Function Selection**

Determines if the STOP key on the digital operator will stop drive operation when the drive is controlled from a remote source (i.e., not from digital operator).

No.	Name	Setting Range	Default
o2-02	STOP Key Function Selection	0, 1	1

**Setting 0: Disabled**

**Setting 1: Enabled**

The STOP key will terminate drive operation even if the Run command source is not assigned to the digital operator. Cycle the Run command to restart the drive if the drive has been stopped by pressing the STOP key.

■ **o2-03: User Parameter Default Value**

After completely setting up drive parameters, save the values as user-set defaults with parameter o2-03. After saving the values, parameter A1-03 (Initialize Parameters) will offer the choice of "1110: User Initialize". Selecting 1110 resets all parameters to the user-set default values. *Refer to A1-03: Initialize Parameters on page 11* for details on drive initialization.

No.	Name	Setting Range	Default
o2-03	User Parameter Default Value	0 to 2	0

**Setting 0: No Change (Awaiting Command)**

**Setting 1: Set User Initialize Values**

The current parameter settings are saved as user-set default for a later User Initialization. Setting o2-03 to 1 and pressing the ENTER key saves the values and returns the display to 0.

**Setting 2: Clear User Initialize Values**

All user-set defaults for "User Initialize" are cleared. Setting o2-03 to 2 and pressing the ENTER key erases the values and returns the display to 0.

■ **o2-04: Drive Model Selection**

Set this parameter when replacing the control board or the terminal board. *Refer to Defaults by Drive Model and Duty Rating ND/HD on page 309* for information on drive model selection.

**NOTICE:** Drive performance will suffer and protective functions will not operate properly if the correct drive capacity is not set to o2-04.

No.	Name	Setting Range	Default
o2-04	Drive Model Selection	-	Determined by drive capacity

**Note:** Change o2-04 setting only when necessary.

■ **o2-05: Frequency Reference Setting Method Selection**

Determines if the ENTER key must be pressed after changing the frequency reference using the digital operator while in the Drive Mode.

No.	Name	Setting Range	Default
o2-05	Frequency Reference Setting Method Selection	0, 1	0

**Setting 0: ENTER key required**

The ENTER key must be pressed every time the frequency reference is changed using the digital operator for the drive to accept the change.

## 1.10 o: Operator Related Settings

### Setting 1: ENTER key not required

The output frequency changes immediately when the reference is changed by the up or down arrow keys on the digital operator. The ENTER key does not need to be pressed. The frequency reference (Fref) is saved to memory after remaining unchanged for 5 seconds.

### ■ o2-06: Operation Selection when Digital Operator is Disconnected

Determines whether the drive will stop when the digital operator is removed in LOCAL mode or when b1-02 or b1-16 is set to 0. When the operator is reconnected, the display will indicate that it was disconnected.

No.	Name	Setting Range	Default
o2-06	Digital Operator Disconnection Operation	0, 1	1

### Setting 0: Continue operation

The operation continues.

### Setting 1: Trigger a fault

The operation stops and triggers an oPr fault. The motor coasts to stop.

### ■ o2-07: Motor Direction at Power Up when Using Operator

Determines the direction the motor will rotate after the drive is powered up and the Run command is given from the digital operator.

**Note:** This parameter is effective only when the Run command is set to be given from the digital operator (b1-02, b1-16 = 0).

No.	Name	Setting Range	Default
o2-07	Motor Direction at Power Up when Using Operator	0, 1	0

### Setting 0: Forward

### Setting 1: Reverse

## ◆ o3: Copy Function

These parameters control the Copy function of the digital operator. The Copy function stores parameter settings into the memory of the digital operator to facilitate the transfer of those settings to other drives that are the same model, capacity, and same control mode setting. [Refer to Copy Function Related Displays on page 219](#) for a description of errors and displays.

### ■ o3-01: Copy Function Selection

Instructs the drive to Read, Write, or Verify parameter settings.

No.	Name	Setting Range	Default
o3-01	Copy Function Selection	0 to 3	0

### Setting 0: Copy Select (no function)

### Setting 1: INV --> OP READ

Copies all parameters from the drive to the digital operator.

**Note:** The copy protection for the digital operator is enabled by default. Set o3-01 to 1 to unlock copy protection.

### Setting 2: OP --> INV WRITE

Copies all parameters from the digital operator to the drive.

### Setting 3: OP<-->INV VERIFY

Compares the parameters in the drive with the parameter settings saved on the digital operator for matches.

### ■ o3-02: Copy Allowed Selection

Allows and restricts the use of the Copy function.

No.	Name	Setting Range	Default
o3-02	Copy Allowed Selection	0, 1	0

Setting 0: Disabled

Setting 1: Enabled

## ◆ o4: Maintenance Monitor Settings

### ■ o4-01: Cumulative Operation Time Setting

Sets the cumulative operation time of the drive. The user can also manually set this parameter to begin keeping track of operation time from some desired value. Total operation time can be viewed in monitor U4-01.

**Note:** The value in o4-01 is set in 10 h units. For example, a setting of 30 will set the cumulative operation time counter to 300 h. 300 h will also be displayed in monitor U4-01.

No.	Name	Setting Range	Default
o4-01	Cumulative Operation Time Setting	0 to 9999 h	0 h

### ■ o4-02: Cumulative Operation Time Selection

Selects the conditions for how the drive keeps track of its total operation time. This time log can be viewed in monitor U4-01.

No.	Name	Setting Range	Default
o4-02	Cumulative Operation Time Selection	0, 1	0

#### Setting 0: Power on time

The drive logs the time it is connected to a power supply, regardless of whether the motor is running.

#### Setting 1: Run time

The drive logs the time that the output is active including when the Run command is active (even if the motor is not rotating) and when there is voltage output.

### ■ o4-03: Cooling Fan Operation Time Setting

Sets the value for how long the cooling fan has been operating. This value can be viewed in monitor U4-03. Parameter o4-03 also sets the base value used for the cooling fan maintenance, which is displayed in U4-04. Reset this parameter to 0 after replacing the cooling fan.

**Note:**

1. The value in o4-03 increases after every 10 hours of use. A setting of 30 will set the cooling fan operation time counter to 300 h. "300" will be displayed in monitor U4-03.
2. The cooling fan may require maintenance at an earlier date in harsher environments.

No.	Name	Setting Range	Default
o4-03	Cooling Fan Operation Time Setting	0 to 9999 h	0 h

### ■ o4-05: Capacitor Maintenance Setting

Sets value of the maintenance monitor for the DC bus capacitors displayed in U4-05 as a percentage of the total expected performance life. Reset this value to 0 after replacing the DC bus capacitors.

**Note:** The actual maintenance time will depend on the environment where the drive is used.

No.	Name	Setting Range	Default
o4-05	Capacitor Maintenance Setting	0 to 150%	0%

### ■ o4-07: DC Bus Pre-Charge Relay Maintenance Setting

Sets the value of the softcharge bypass relay maintenance time displayed in U4-06 as a percentage of the total expected performance life. Reset this value to 0 after replacing the bypass relay.

**Note:** The actual maintenance time will depend on the environment where the drive is used.

No.	Name	Setting Range	Default
o4-07	DC Bus Pre-charge Relay Maintenance Setting	0 to 150%	0%

### ■ o4-09: IGBT Maintenance Setting

Sets the value of the IGBT maintenance time displayed in U4-07 as a percentage of the total expected performance life. Reset this value to 0 after replacing the IGBTs.

**Note:** The actual maintenance time will depend on the environment where the drive is used.

## 1.10 o: Operator Related Settings

---

No.	Name	Setting Range	Default
o4-09	IGBT Maintenance Setting	0 to 150%	0%

### ■ o4-11: U2, U3 Initialization

Resets the fault trace and fault history monitors (U2-□□ and U3-□□). Initializing the drive using A1-03 does not reset these monitors.

No.	Name	Setting Range	Default
o4-11	U2, U3 Initialization	0, 1	0

#### Setting 0: No Action

The drive keeps the previously saved record concerning fault trace and fault history.

#### Setting 1: Reset Fault Data

Resets the data for the U2-□□ and U3-□□ monitors. Setting o4-11 to 1 and pressing the ENTER key erases fault data and returns the display to 0.

### ■ o4-12: kWh Monitor Initialization

Resets the kWh monitors U4-10 and U4-11. Initializing the drive or cycling the power does not reset these monitors.

No.	Name	Setting Range	Default
o4-12	kWh Monitor Initialization	0, 1	0

#### Setting 0: No Action

The kWh data are maintained.

#### Setting 1: Reset kWh Data

Resets the kWh counter. The monitors U4-10 and U4-11 will display “0” after they are initialized. Setting o4-12 to 1 and pressing the ENTER erases kWh data and returns the display to 0.

### ■ o4-13: Number of Run Commands Counter Initialization

Resets the Run command counter displayed in U4-02. Initializing the drive or cycling the power does not reset this monitor.

No.	Name	Setting Range	Default
o4-13	Number of Run Commands Counter Initialization	0, 1	0

#### Setting 0: No Action

The Run command data are kept.

#### Setting 1: Number of Run Commands Counter

Resets the Run command counter. The monitor U4-02 will show 0. Setting o4-13 to 1 and pressing the ENTER key erases the counter value and returns the display to 0.

---

## ◆ q: DriveWorksEZ Parameters

These parameters are reserved for use with DriveWorksEZ. Refer to the DriveWorksEZ manual for more information.

### ■ q1-01 to q6-07: Reserved for Use by DriveWorksEZ

These parameters are reserved for use with DriveWorksEZ. Refer to the DriveWorksEZ manual for more information.

---

## ◆ r: DriveWorksEZ Connection Parameters

These parameters are reserved for use with DriveWorksEZ. Refer to the DriveWorksEZ manual for more information.

### ■ r1-01 to r1-40: DriveWorksEZ Connection Parameters

These parameters are reserved for use with DriveWorksEZ. Refer to the DriveWorksEZ manual for more information.

## 1.11 T: Motor Tuning

Auto-Tuning automatically sets and tunes parameters required for optimal motor performance.

### ◆ T1: Parameter Settings during Induction Motor Auto-Tuning

The T1-□□ parameters set the Auto-Tuning input data for induction motor tuning.

**Note:** For motors operating in the field weakening range, first perform the Auto-Tuning with the base data. After Auto-Tuning is complete, change E1-04, Maximum Output Frequency, to the desired value.

#### ■ T1-00: Motor 1/Motor 2 Selection

Selects the motor to be tuned when motor 1/2 switching is enabled (i.e., a digital input is set for function H1-□□ = 16). This parameter is not displayed if motor 1/2 switching is disabled.

No.	Name	Setting Range	Default
T1-00	Motor 1/Motor 2 Selection	1, 2	1

#### Setting 1: Motor 1

Auto-Tuning automatically sets parameters E1-□□ and E2-□□ for motor 1.

#### Setting 2: Motor 2

Auto-Tuning automatically sets parameters E3-□□ and E4-□□ for motor 2. Make sure that motor 2 is connected to the drive for Auto-Tuning.

#### ■ T1-01: Auto-Tuning Mode Selection

Sets the type of Auto-Tuning to be used.

No.	Name	Setting Range	Default
T1-01	Auto-Tuning Mode Selection	2, (V/f) 0 to 2, 4 (OLV, CLV)	2 (V/f, V/f w/PG) 0 (OLV, CLV)

#### Setting 0: Rotational Auto-Tuning

#### Setting 1: Stationary Auto-Tuning 1

#### Setting 2: Stationary Auto-Tuning for Line-to-Line Resistance

#### Setting 4: Stationary Auto-Tuning 2

#### ■ T1-02: Motor Rated Power

Sets the motor rated power according to the motor nameplate value.

No.	Name	Setting Range	Default
T1-02	Motor Rated Power	0.00 to 650.00 kW	Determined by o2-04 and C6-01

#### ■ T1-03: Motor Rated Voltage

Sets the motor rated voltage according to the motor nameplate value. Enter the voltage base speed here if the motor is operating above base speed.

Enter the voltage needed to operate the motor under no-load conditions at rated speed to T1-03 for better control precision around rated speed when using a vector control mode. The no-load voltage can usually be found in the motor test report available from the manufacturer. If the motor test report is not available, enter approximately 90% of the rated voltage printed on the motor nameplate. This may increase the output current and reduce the overload margin.

No.	Name	Setting Range	Default
T1-03	Motor Rated Voltage	0.0 to 510.0 V <I>	400.0 V <I>

<I> Values shown are specific to 400 V class drives. Multiply the value by 1.4375 for 575 V class drives. Multiply the value by 1.725 for 690 V class drives.

## 1.11 T: Motor Tuning

### ■ T1-04: Motor Rated Current

Sets the motor rated current according to the motor nameplate value. Set the motor rated current between 50% and 100% of the drive rated current for optimal performance in OLV or CLV. Enter the current at the motor base speed.

No.	Name	Setting Range	Default
T1-04	Motor Rated Current	10 to 200% of drive rated current	E2-01 (E4-01)

### ■ T1-05: Motor Base Frequency

Sets the motor rated frequency according to the motor nameplate value. If a motor with an extended speed range is used or the motor is used in the field weakening area, enter the maximum frequency to E1-04 (E3-04 for motor 2) after Auto-Tuning is complete.

No.	Name	Setting Range	Default
T1-05	Motor Base Frequency	0.0 to 400.0 Hz	60.0 Hz

### ■ T1-06: Number of Motor Poles

Sets the number of motor poles according to the motor nameplate value.

No.	Name	Setting Range	Default
T1-06	Number of Motor Poles	2 to 48	4

### ■ T1-07: Motor Base Speed

Sets the motor rated speed according to the motor nameplate value. Enter the speed at base frequency when using a motor with an extended speed range or if using the motor in the field weakening area.

No.	Name	Setting Range	Default
T1-07	Motor Base Speed	0 to 24000 r/min	1750 r/min

### ■ T1-08: PG Number of Pulses Per Revolution

Sets the number of pulses from the PG encoder. Set the actual number of pulses for one full motor rotation.

No.	Name	Setting Range	Default
T1-08	PG Number of Pulses Per Revolution	1 to 60000 ppr	1024 ppr

**Note:** T1-08 will only be displayed in CLV.

### ■ T1-09: Motor No-Load Current

Sets the no-load current for the motor. The default setting displayed is no-load current automatically calculated from the output power set in T1-02 and the motor rated current set to T1-04. Enter the data listed on the motor test report. Leave this data at the default setting if the motor test report is not available.

No.	Name	Setting Range	Default
T1-09	Motor No-Load Current	0 A to [T1-04] (Max: 0 to 2999.9)	–

**Note:** The number of decimal places in the parameter value depends on the drive model and the ND/HD selection in parameter C6-01. This value has two decimal places (0.01 A) if the drive is set for a maximum applicable motor capacity up to and including 11 kW, and one decimal place (0.1 A) if the maximum applicable motor capacity is higher than 11 kW.

### ■ T1-10: Motor Rated Slip

Sets the rated slip for the motor. The default setting displayed is the rated slip for a Yaskawa motor calculated from the output power set in T1-02. Enter the data listed on the motor test report.

No.	Name	Setting Range	Default
T1-10	Motor Rated Slip	0.00 to 20.00 Hz	–

### ■ T1-11: Motor Iron Loss

Provides iron loss information to determine the Energy Saving coefficient. T1-11 will first display the value for the motor iron loss that the drive automatically calculated the when motor capacity was entered to T1-02. Enter the motor iron loss value listed to T1-11 if the motor test report is available.

No.	Name	Setting Range	Default
T1-11	Motor Iron Loss	0 to 65535 W	14 W Differs depending on motor code and motor parameter settings.

### ◆ Parameter Settings during Inertia and Speed Control Loop Auto-Tuning: T3

These tuning methods apply a sine wave test signal to the system. The drive estimates the system inertia by the measuring the response and automatically sets the parameters listed in [Table 1.43](#).

**Table 1.43 Parameters Adjusted by Inertia and Speed Loop Auto-Tuning**

Parameter	Description	T1-01 or T2-01	
		8 Inertia Tuning	9 Speed Control Loop (ASR) Tuning
C5-01	ASR Proportional Gain 1	–	YES
C5-17 (C5-37)	Motor Inertia	YES	YES
C5-18 (C5-38)	Motor Inertia Ratio	YES	YES
L3-24	Motor Acceleration Time for Inertia Calculations	YES	YES
L3-25	Load Inertia Ratio	YES	YES
n5-03	Feed Forward Control Ratio Gain	YES	YES

### ■ T3-01: Inertia Tuning Frequency Reference

Sets the frequency of the test signal applied to the motor during Inertia Tuning. Although this setting rarely needs to be changed, increasing the value may be beneficial when working with high inertia loads.

No.	Name	Setting Range	Default
T3-01	Inertia Tuning Frequency Reference	0.1 to 20.0 Hz	3.0 Hz

### ■ T3-02: Inertia Tuning Reference Amplitude

Enter the amplitude of the test signal applied to the motor during Inertia Tuning. Although this setting rarely needs to be changed, decrease the setting if a large load inertia causes problems during Inertia Tuning. Adjust T3-02 if a fault occurs when T3-01 is set to a low value.

No.	Name	Setting Range	Default
T3-02	Inertia Tuning Reference Amplitude	0.1 to 10.0 rad	0.5 rad

### ■ T3-03: Motor Inertia

Enter the inertia of the motor. This value is used to determine the load inertia using the test signal response. The default setting is for a Yaskawa standard motor as listed in the motor inertia table.

No.	Name	Setting Range	Default
T3-03	Motor Inertia	0.0001 to 600.00 kgm <sup>2</sup>	Determined by E2-11

**Note:** Capacities 0.1 to 37 kW are set in units of 0.001 kgm<sup>2</sup>. Capacities 5.5 to 45 kW are set in units of 0.001 kgm<sup>2</sup>. Capacities 55 kW and above are set in units of 0.01 kgm<sup>2</sup>.

### ■ T3-04: ASR Response Frequency

Sets the response frequency (reciprocal of the step response time constant) of the system or the connected machine. The drive uses this value and the load inertia to fine-tune the speed control loop gain (C5-01, ASR Gain 1). Oscillation may result if the value input here is higher than the actual response frequency of the system.

## 1.11 T: Motor Tuning

---

No.	Name	Setting Range	Default
T3-04	ASR Response Frequency	0.1 to 50.0 Hz	10.0 Hz



## 1.12 U: Monitor Parameters

Monitor parameters let the user view various aspects of drive performance using the digital operator display. Some monitors can be output from terminals FM and AM by assigning the specific monitor parameter number (U□-□□) to H4-01 and H4-04. *Refer to H4-01, H4-04: Multi-Function Analog Output Terminal FM, AM Monitor Selection on page 120* for details on assigning functions to an analog output.

### ◆ U1: Operation Status Monitors

Status monitors display drive status data such as output frequency and output current. *Refer to U1: Operation Status Monitors on page 296* for a complete list of U1-□□ monitors and descriptions.

### ◆ U2: Fault Trace

Use these monitor parameters to view the status of various drive aspects when a fault occurs.

This information is helpful for determining the cause of a fault. *Refer to U2: Fault Trace on page 298* for a complete list of U2-□□ monitors and descriptions.

U2-□□ monitors are not reset when the drive is initialized. *Refer to o4-11: U2, U3 Initialization on page 164* for instructions on how to reset these monitor values.

### ◆ U3: Fault History

These parameters display faults that have occurred during operation as well as the drive operation time when those faults occurred. *Refer to U3: Fault History on page 300* for a complete list of U3-□□ monitors and descriptions.

U3-□□ monitors are not reset when the drive is initialized. *Refer to o4-11: U2, U3 Initialization on page 164* for instructions on how to reset these monitor values.

### ◆ U4: Maintenance Monitors

Maintenance monitors show:

- Runtime data of the drive and cooling fans and number of Run commands issued
- Maintenance data and replacement information for various drive components
- kWh data
- Highest peak current that has occurred and output frequency at the time the peak current occurred
- Motor overload status information
- Detailed information about the present Run command and frequency reference source selection

*Refer to U4: Maintenance Monitors on page 300* for a complete list of U4-□□ monitors and descriptions.

### ◆ U5: PID Monitors

These monitors display various aspects of PID control. *Refer to PID Block Diagram on page 35* for details on how these monitors display PID data.

*Refer to U5: PID Monitors on page 303* for a complete list of U5-□□ monitors and descriptions.

### ◆ U6: Operation Status Monitors

Control monitors show:

- Reference data for the output voltage and vector control
- Data on PM motor rotor synchronization, forward phase compensation, and flux positioning
- Pulse data from the PG motor encoder
- Pulse data for Zero Servo control
- ASR and Feed Forward control monitors

Refer to *Figure 1.34* and *Figure 1.35* on page 53 for details and an illustration showing where monitors are located in the ASR block.

- The offset value added to the frequency reference by the frequency offset function. *Refer to Setting 44, 45, 46: Offset Frequency 1, 2, 3 on page 102.*

## 1.12 U: Monitor Parameters

---

- The bias value added to the frequency reference by the Up/Down 2 function (see [Setting 75, 76: Up 2/Down 2 Function](#))  
[Refer to U6: Operation Status Monitors on page 303](#) for a complete list of U6-□□ monitors and descriptions.
- 

### ◆ U8: DriveWorksEZ Monitors

These monitors are reserved for use with DriveWorksEZ.

A complete description of the U8-□□ monitors can be found in the DriveWorksEZ instruction manual.

# Troubleshooting

---

This chapter provides descriptions of the drive faults, alarms, errors, related displays, and guidance for troubleshooting. This chapter can also serve as a reference guide for tuning the drive during a trial run.

<b>2.1</b>	<b>SECTION SAFETY.....</b>	<b>172</b>
<b>2.2</b>	<b>MOTOR PERFORMANCE FINE-TUNING.....</b>	<b>174</b>
<b>2.3</b>	<b>DRIVE ALARMS, FAULTS, AND ERRORS.....</b>	<b>177</b>
<b>2.4</b>	<b>FAULT DETECTION.....</b>	<b>182</b>
<b>2.5</b>	<b>ALARM DETECTION.....</b>	<b>201</b>
<b>2.6</b>	<b>OPERATOR PROGRAMMING ERRORS.....</b>	<b>210</b>
<b>2.7</b>	<b>AUTO-TUNING FAULT DETECTION.....</b>	<b>214</b>
<b>2.8</b>	<b>COPY FUNCTION RELATED DISPLAYS.....</b>	<b>219</b>
<b>2.9</b>	<b>DIAGNOSING AND RESETTING FAULTS.....</b>	<b>221</b>
<b>2.10</b>	<b>TROUBLESHOOTING WITHOUT FAULT DISPLAY.....</b>	<b>223</b>

## 2.1 Section Safety

### DANGER

#### Electrical Shock Hazard

**Do not connect or disconnect wiring while the power is on.**

Failure to comply will result in death or serious injury.

### WARNING

#### Electrical Shock Hazard

**Do not operate equipment with covers removed.**

Failure to comply could result in death or serious injury.

The diagrams in this section may illustrate drives without covers or safety shields to display details. Be sure to reinstall covers or shields before operating the drives and run the drives according to the instructions described in this manual.

**Always ground the motor-side grounding terminal.**

Improper equipment grounding could result in death or serious injury by contacting the motor case.

**Do not touch terminals before the capacitors have fully discharged.**

Failure to comply could result in death or serious injury.

Before wiring terminals, disconnect all power to the equipment. The internal capacitor remains charged even after the drive input power is turned off. After shutting off the power, wait for at least the amount of time specified on the drive before touching any components.

**After blowing a fuse or tripping a GFCI, do not attempt to restart the drive or operate peripheral devices until five minutes pass and CHARGE lamp is OFF.**

Failure to comply could result in death, serious injury, and damage to the drive.

Check wiring and peripheral device ratings to identify the cause of trips.

Contact your supplier if the cause cannot be identified.

**Do not allow unqualified personnel to perform work on the drive.**

Failure to comply could result in death or serious injury.

Installation, maintenance, inspection and servicing must be performed only by authorized personnel familiar with installation, adjustment and maintenance of AC drives.

**Do not perform work on the drive while wearing loose clothing, jewelry, or without eye protection.**

Failure to comply could result in death or serious injury.

Remove all metal objects such as watches and rings, secure loose clothing and wear eye protection before beginning work on the drive.

**Do not remove covers or touch circuit boards while the power is on.**

Failure to comply could result in death or serious injury.

#### Fire Hazard

**Tighten all terminal screws to the specified tightening torque.**

Loose electrical connections could result in death or serious injury by fire due to overheating of electrical connections.

**Do not use an improper voltage source.**

Failure to comply could result in death or serious injury by fire.

Verify that the rated voltage of the drive matches the voltage of the incoming drive input power before applying power.

**Do not use improper combustible materials.**

Failure to comply could result in death or serious injury by fire.

Attach the drive to metal or other noncombustible material.

**NOTICE**

**Observe proper electrostatic discharge procedures (ESD) when handling the drive and circuit boards.**

Failure to comply may result in ESD damage to the drive circuitry.

**Never connect or disconnect the motor from the drive while the drive is outputting voltage.**

Improper equipment sequencing could result in damage to the drive.

**Do not use unshielded cable for control wiring.**

Failure to comply may cause electrical interference resulting in poor system performance. Use shielded twisted-pair wires and ground the shield to the ground terminal of the drive.

**Do not allow unqualified personnel to use the product.**

Failure to comply could result in damage to the drive or braking circuit.

Carefully review instruction manual TOBPC72060000 when connecting a dynamic braking option to the drive.

**Do not modify the drive circuitry.**

Failure to comply could result in damage to the drive and will void warranty.

Yaskawa is not responsible for modification of the product made by the user.

**Check all the wiring after installing the drive and connecting other devices to ensure that all connections are correct.**

Failure to comply could result in damage to the drive.

# 2.2 Motor Performance Fine-Tuning

This section offers helpful information for counteracting oscillation, hunting, and other problems that occur while performing a trial run. Refer to the section below that corresponds to the motor control method used.

**Note:** This section describes commonly edited parameters that may be set incorrectly. Consult Yaskawa for more information on detailed settings and for fine-tuning the drive.

### ◆ Fine-Tuning V/f Control and V/f Control with PG

**Table 2.1 Parameters for Fine-Tuning Performance in V/f and V/f w/PG**

Problem	Parameter No.	Corrective Action	Default	Suggested Setting
Motor hunting and oscillation at speeds between 10 and 40 Hz	Hunting Prevention Gain (n1-02)	<ul style="list-style-type: none"> <li>Reduce the setting if insufficient motor torque relative to the size of the load causes hunting.</li> <li>Increase the setting when motor hunting and oscillation occur with a light load.</li> <li>Reduce the setting if hunting occurs when using a motor with a relatively low inductance, such as a high-frequency motor or a motor with a larger frame size.</li> </ul>	1.00	0.10 to 2.00
<ul style="list-style-type: none"> <li>Motor noise</li> <li>Motor hunting and oscillation at speeds up to 40 Hz</li> </ul>	Carrier Frequency Selection (C6-02)	<ul style="list-style-type: none"> <li>Increase the carrier frequency if the motor noise is too loud.</li> <li>Lower the carrier frequency when motor hunting and oscillation occur at speeds up to 40 Hz.</li> <li>The default setting for the carrier frequency depends on the drive capacity (o2-04) and the duty selection (C6-01).</li> </ul>	1 (2 kHz)	1 to max. setting
<ul style="list-style-type: none"> <li>Poor torque or speed response</li> <li>Motor hunting and oscillation</li> </ul>	Torque Compensation Primary Delay Time (C4-02)	<ul style="list-style-type: none"> <li>Reduce the setting if motor torque and speed response are too slow.</li> <li>Increase the setting if motor hunting and oscillation occur.</li> </ul>	200 ms	100 to 1000 ms
<ul style="list-style-type: none"> <li>Poor motor torque at speeds below 10 Hz</li> <li>Motor hunting and oscillation</li> </ul>	Torque Compensation Gain (C4-01)	<ul style="list-style-type: none"> <li>Increase the setting if motor torque is insufficient at speeds below 10 Hz.</li> <li>Reduce the setting if motor hunting and oscillation with a relatively light load.</li> </ul>	1.00	0.50 to 1.50
<ul style="list-style-type: none"> <li>Poor motor torque at low speeds</li> <li>Motor instability at motor start</li> </ul>	Mid Output Voltage A (E1-08) Minimum Output Voltage (E1-10)	<ul style="list-style-type: none"> <li>Increase the setting if motor torque is insufficient at speeds below 10 Hz.</li> <li>Reduce the setting if motor instability occurs at motor start.</li> </ul>	Depends on o2-04, Drive Model Selection	Default setting ±5 V
Poor speed precision (V/f control)	Slip Compensation Gain (C3-01)	Set the motor-rated current (E2-01), motor-rated slip (E2-02), and motor no-load current (E2-03), then adjust the slip compensation gain (C3-01).	0.0 (no slip compensation)	0.5 to 1.5
Poor speed precision (V/f control with PG)	ASR Proportional Gain 1 (C5-01) ASR Integral Time 1 (C5-02) <1> <2>	Adjust the ASR proportional gain 1 (C5-01) and the ASR integral time 1 (C5-02).	C5-01: 0.20 C5-02: 0.200	Proportional gain = 0.10 to 1.00 Integral time = 0.100 to 2.000

<1> ASR in V/f Control with PG only controls the output frequency, and does not allow the same high gain settings as CLV control.

<2> [Refer to C5: Automatic Speed Regulator \(ASR\) on page 53](#) for details on ASR.

◆ Fine-Tuning Open Loop Vector Control

Table 2.2 Parameters for Fine-Tuning Performance in OLV

Problem	Parameter No.	Corrective Action	Default	Suggested Setting
<ul style="list-style-type: none"> <li>Poor motor torque and speed response</li> <li>Motor hunting and oscillation at speeds between 10 and 40 Hz</li> </ul>	AFR Gain (n2-01)	<ul style="list-style-type: none"> <li>Gradually reduce the setting in 0.05 increments if motor torque and speed response are too slow.</li> <li>Gradually increase the setting in 0.05 increments if motor hunting and oscillation occur.</li> </ul>	1.00	0.50 to 2.00
<ul style="list-style-type: none"> <li>Poor motor torque and speed response</li> <li>Motor hunting and oscillation at speeds between 10 and 40 Hz</li> </ul>	AFR Time Constant 1 (n2-02)	<ul style="list-style-type: none"> <li>Gradually reduce the setting in 10 ms increments and check the performance to improve motor torque speed response.</li> <li>Gradually increase the setting by 50 ms increments and check the performance if motor hunting and oscillation occur as a result of load inertia.</li> </ul> <p><b>Note:</b> Ensure that <math>n2-02 \leq n2-03</math>. When changing n2-02, set C4-02 (Torque Compensation Primary Delay Time Constant 1) accordingly.</p>	50 ms	50 to 2000 ms
Overvoltage trips when accelerating, decelerating, or during sudden speed or load changes	AFR Time Constant 2 (n2-03)	<ul style="list-style-type: none"> <li>Gradually increase the setting in 50 ms increments if overvoltage occurs.</li> <li>Gradually reduce the setting in 10 ms increments if response is slow.</li> </ul> <p><b>Note:</b> Ensure that <math>n2-02 \leq n2-03</math>. When making adjustments to n2-03, increase the value of C4-06 (Torque Compensation Primary Delay Time 2) proportionally.</p>	750 ms	750 to 2000 ms
	Torque Compensation Primary Delay Time Constant 2 (C4-06)	<ul style="list-style-type: none"> <li>Gradually increase the setting in 10 ms increments and check the performance if overvoltage trips occur.</li> <li>Gradually reduce the setting in 2 ms increments and check the performance if response is slow.</li> </ul> <p><b>Note:</b> Ensure that <math>C4-02 \leq C4-06</math>. When changing C4-06 (Torque Compensation Primary Delay Time Constant 2), increase the value of n2-03 proportionally.</p>	150 ms	150 to 750 ms
<ul style="list-style-type: none"> <li>Poor motor torque and speed response</li> <li>Motor hunting and oscillation</li> </ul>	Torque Compensation Primary Delay Time Constant 1 (C4-02)	<ul style="list-style-type: none"> <li>Gradually reduce the setting in 2 ms increments and check the performance to improve motor torque speed response.</li> <li>Gradually increase the setting in 10 ms increments if motor hunting and oscillation occur.</li> </ul> <p><b>Note:</b> Ensure that <math>C4-02 \leq C4-06</math>. When making adjustments to C4-02, increase the AFR time constant (n2-02) proportionally.</p>	20 ms	20 to 100 ms
Poor speed response and stability	Slip Compensation Primary Delay Time Constant (C3-02)	<ul style="list-style-type: none"> <li>Gradually reduce the setting in 10 ms increments if response is slow.</li> <li>Gradually increase the setting in 10 ms increments if speed is unstable.</li> </ul>	200 ms	100 to 500 ms
Poor speed precision	Slip Compensation Gain (C3-01)	<ul style="list-style-type: none"> <li>Gradually increase the setting in 0.1 ms increments if speed is too slow.</li> <li>Gradually reduce the setting in 0.1 ms increments if speed is too fast.</li> </ul>	1.0	0.5 to 1.5
Poor speed precision during regenerative operation	Slip Compensation Selection During Regeneration (C3-04)	Enable slip compensation during regeneration by setting parameter C3-04 = 1.	0	1
<ul style="list-style-type: none"> <li>Motor noise</li> <li>Motor hunting and oscillation occur at speeds below 10 Hz</li> </ul>	Carrier Frequency Selection (C6-02)	<ul style="list-style-type: none"> <li>Increase the carrier frequency if there is too much motor noise.</li> <li>Reduce the carrier frequency if motor hunting and oscillation occur at low speeds.</li> </ul> <p><b>Note:</b> The default setting for the carrier frequency depends on the drive capacity (o2-04) and Duty Selection (C6-01).</p>	1 (2 kHz)	0 to max. setting
<ul style="list-style-type: none"> <li>Poor motor torque at low speeds</li> <li>Poor speed response</li> <li>Motor instability at start</li> </ul>	Mid Output Voltage A (E1-08) Minimum Output Voltage (E1-10)	<ul style="list-style-type: none"> <li>Increase the setting if motor torque and speed response are too slow.</li> <li>Reduce the setting if the motor exhibits excessive instability at start-up.</li> </ul> <p><b>Note:</b> When working with a relatively light load, increasing this value too much can cause overtorque.</p>	Depends on o2-04, Drive Model Selection	Default setting $\pm 2$ V

When using OLV, leave the torque compensation gain (C4-01) at its default setting of 1.00.

### ◆ Parameters to Minimize Motor Hunting and Oscillation

Parameters in [Table 2.3](#) indirectly affect motor hunting and oscillation.

**Table 2.3 Parameters that Affect Control Performance in Applications**

Name (Parameter No.)	Application
<b>Dwell Function</b> (b6-01 through b6-04)	Prevents motor speed loss by maintaining the output frequency when working with heavy loads or when there is powerful backlash on the machine side.
<b>Droop Function</b> (b7-01, b7-02)	Balances the load between two motors driving the same load when A1-02 is set to 3 or 7.
<b>Accel/Decel Time</b> (C1-01 through C1-11)	Adjusting accel and decel times will affect the torque presented to the motor during acceleration or deceleration.
<b>S-Curve Characteristics</b> (C2-01 through C2-04)	Prevents shock at the beginning and end of acceleration and deceleration.
<b>Jump Frequency</b> (d3-01 through d3-04)	Skips over the resonant frequencies of connected machinery.
<b>Analog Filter Time Constant</b> (H3-13)	Prevents fluctuation in the analog input signal due to noise.
<b>Stall Prevention</b> (L3-01 through L3-06, L3-11)	<ul style="list-style-type: none"> <li>• Prevents motor speed loss and overvoltage when the load is too heavy or during sudden acceleration/ deceleration.</li> <li>• Adjustment is not normally necessary because Stall Prevention is enabled as a default. Set L3-04 to 0 to disable Stall Prevention during deceleration when using a braking resistor.</li> </ul>
<b>Torque Limits</b> (L7-01 through L7-04, L7-06, L7-07)	<ul style="list-style-type: none"> <li>• Sets the maximum torque for OLV Control.</li> <li>• Ensure that the drive capacity is greater than the motor capacity when increasing this setting. Motor speed loss may occur with heavy loads.</li> </ul>
<b>Feed Forward Control</b> (n5-01 through n5-03)	Increases response for acceleration/deceleration and reduces overshooting when there is low machine rigidity and ASR gain cannot be increased. Set the inertia ratio between the load and motor and the acceleration time of the motor running alone.



## 2.3 Drive Alarms, Faults, and Errors

### ◆ Types of Alarms, Faults, and Errors

Check the digital operator for information about possible faults if the drive or motor fails to operate.

If problems occur that are not covered in this manual, contact the nearest Yaskawa representative with the following information:

- Drive model
- Software version
- Date of purchase
- Description of the problem

**Table 2.4** contains descriptions of the various types of alarms, faults, and errors that may occur while operating the drive.

**Table 2.4 Types of Alarms, Faults, and Errors**

Type	Drive Response
<b>Faults</b>	<p>When the drive detects a fault:</p> <ul style="list-style-type: none"> <li>• The digital operator displays text indicating the specific fault and the ALM indicator LED remains lit until the fault is reset.</li> <li>• The fault interrupts drive output and the motor coasts to a stop.</li> <li>• Some faults allow the user to select the stopping method when the fault occurs.</li> <li>• Fault output terminals MA-MC will close, and MB-MC will open.</li> </ul> <p>The drive will remain inoperable until the fault is cleared. <a href="#">Refer to Fault Reset Methods on page 222.</a></p>
<b>Minor Faults and Alarms</b>	<p>When the drive detects an alarm or a minor fault:</p> <ul style="list-style-type: none"> <li>• The digital operator displays text indicating the specific alarm or minor fault, and the ALM indicator LED flashes.</li> <li>• The drive continues running the motor, although some alarms allow the user to select a stopping method when the alarm occurs.</li> <li>• A multi-function contact output set to be tripped by a minor fault (H2- □□ = 10) closes. If the output is set to be tripped by an alarm, the contact will not close.</li> <li>• The digital operator displays text indicating a specific alarm and the ALM indicator LED flashes.</li> </ul> <p>Remove the cause of the problem to reset a minor fault or alarm.</p>
<b>Operation Errors</b>	<p>An operation error occurs when parameter settings conflict or do not match hardware settings (such as with an option card). When the drive detects an operation error:</p> <ul style="list-style-type: none"> <li>• The digital operator displays text indicating the specific error.</li> <li>• Multi-function contact outputs do not operate.</li> </ul> <p>The drive will not operate the motor until the error has been reset. Correct the settings that caused the operation error to clear the error.</p>
<b>Tuning Errors</b>	<p>Tuning errors occur while performing Auto-Tuning. When the drive detects a tuning error:</p> <ul style="list-style-type: none"> <li>• The digital operator displays text indicating the specific error.</li> <li>• Multi-function contact outputs do not operate.</li> <li>• Motor coasts to stop.</li> </ul> <p>Remove the cause of the error and repeat the Auto-Tuning process.</p>
<b>Copy Function Errors</b>	<p>Copy Function Errors occur when using the digital operator or the USB Copy Unit to copy, read, or verify parameter settings.</p> <ul style="list-style-type: none"> <li>• The digital operator displays text indicating the specific error.</li> <li>• Multi-function contact outputs do not operate.</li> </ul> <p>Pressing any key on the digital operator will clear the fault. Investigate the cause of the problem (such as model incompatibility) and try again.</p>

### ◆ Alarm and Error Displays

#### ■ Faults

**Table 2.5** gives an overview of possible fault codes. Conditions such as overvoltages can trip faults and alarms. It is important to distinguish between faults and alarms to determine the proper corrective actions.

When the drive detects a fault, the ALM indicator LED lights, the fault code appears on the digital operator, and the fault contact MA-MB-MC triggers. An alarm is present if the ALM LED blinks and the fault code on the digital operator flashes. [Refer to Minor Faults and Alarms on page 179](#) for a list of alarm codes.

## 2.3 Drive Alarms, Faults, and Errors

Table 2.5 Fault Displays

Digital Operator Display	Name	Page	Digital Operator Display	Name	Page		
<i>boL</i>	boL	Braking Transistor Overload Fault	<a href="#">182</a>	<i>oFAR01</i>	oFA01	Option Card Fault (CN5-A)	<a href="#">190</a>
<i>bUS</i>	bUS	Option Communication Error	<a href="#">182</a>	<i>oFAR03 to oFAR06</i>	oFA03 to oFA06	Option Card Error (CN5-A)	<a href="#">190</a>
<i>CE</i>	CE	MEMOBUS/Modbus Communication Error	<a href="#">182</a>	<i>oFAR10, oFAR11</i>	oFA10, oFA11	Option Card Error (CN5-A)	<a href="#">190</a>
<i>CF</i>	CF	Control Fault	<a href="#">182</a>	<i>oFAR12 to oFAR17</i>	oFA12 to oFA17	Option Card Connection Error (CN5-A)	<a href="#">190</a>
<i>CPF00, CPF01</i>	CPF11 to CPF14	Control Circuit Error	<a href="#">183</a>	<i>oFAR30 to oFAR43</i>	oFA30 to oFA43	Comm Option Card Connection Error (CN5-A)	<a href="#">190</a>
<i>&lt;I&gt;</i>	CPF16 to CPF19	Control Circuit Error	<a href="#">183</a>	<i>oFb00</i>	oFb00	Option Card Connection Error (CN5-B)	<a href="#">190</a>
<i>CPF02</i>	CPF02	A/D Conversion Error	<a href="#">183</a>	<i>oFb01</i>	oFb01	Option Card Fault (CN5-B)	<a href="#">190</a>
<i>CPF03</i>	CPF03	Control Board Connection Error	<a href="#">183</a>	<i>oFb02</i>	oFb02	Option Card Fault (CN5-B)	<a href="#">190</a>
<i>CPF06</i>	CPF06	EEPROM Memory Data Error	<a href="#">183</a>	<i>oFb03, oFb11</i>	oFb03, oFb11	Option Card Error (CN5-B)	<a href="#">191</a>
<i>CPF07, CPF08</i>	CPF07, CPF08	Terminal Board Connection Error	<a href="#">183</a>	<i>oFb12 to oFb17</i>	oFb12 to oFb17	Option Card Connection Error (CN5-B)	<a href="#">191</a>
<i>CPF20, CPF21</i>	CPF20, CPF21	Control Circuit Error	<a href="#">183</a>	<i>oFC00</i>	oFC00	Option Card Connection Error (CN5-C)	<a href="#">191</a>
<i>CPF22</i>	CPF22	Hybrid IC Error	<a href="#">184</a>	<i>oFC01</i>	oFC01	Option Card Fault (CN5-C)	<a href="#">191</a>
<i>CPF23</i>	CPF23	Control Board Connection Error	<a href="#">184</a>	<i>oFC02</i>	oFC02	Option Card Fault (CN5-C)	<a href="#">191</a>
<i>CPF24</i>	CPF24	Drive Unit Signal Fault	<a href="#">184</a>	<i>oFC03, oFC11</i>	oFC03, oFC11	Option Card Error (CN5-C)	<a href="#">191</a>
<i>CPF26 to CPF34, CPF40 to CPF45</i>	CPF26 to CPF34, CPF40 to CPF45	Control Circuit Error	<a href="#">184</a>	<i>oFC12 to oFC17</i>	oFC12 to oFC17	Option Card Connection Error (CN5-C)	<a href="#">191</a>
<i>dEv</i>	dEv	Excessive Speed Deviation (for Control Mode with PG)	<a href="#">184</a>	<i>oH</i>	oH	Heatsink Overheat	<a href="#">191</a>
<i>dFAn</i>	dFAn	Abnormal Diode Module Fan	<a href="#">184</a>	<i>oH1</i>	oH1	Heatsink Overheat	<a href="#">192</a>
<i>dv1</i>	dv1	Z Pulse Fault Detection	<a href="#">185</a>	<i>oH3</i>	oH3	Motor Overheat Alarm (PTC input)	<a href="#">192</a>
<i>dv2</i>	dv2	Z Pulse Noise Fault Detection	<a href="#">185</a>	<i>oH4</i>	oH4	Motor Overheat Fault (PTC input)	<a href="#">192</a>
<i>dv3</i>	dv3	Inversion Detection	<a href="#">185</a>	<i>oH5 &lt;S&gt;</i>	oH5	Motor Overheat (NTC Input)	<a href="#">192</a>
<i>dv4</i>	dv4	Inversion Prevention Detection	<a href="#">185</a>	<i>oH6</i>	oH6	Converter heating	<a href="#">193</a>
<i>dv7 &lt;S&gt;</i>	dv7	Polarity Judge Timeout	<a href="#">185</a>	<i>oL1</i>	oL1	Motor Overload	<a href="#">193</a>
<i>dWFL</i>	dWFL	DriveWorksEZ Fault	<a href="#">186</a>	<i>oL2</i>	oL2	Drive Overload	<a href="#">193</a>
<i>E5</i>	E5	SI-T3 Watchdog Timer Error	<a href="#">186</a>	<i>oL3</i>	oL3	Overtorque Detection 1	<a href="#">194</a>
<i>EFAAn</i>	EFAAn	Abnormal Panel Fan	<a href="#">186</a>	<i>oL4</i>	oL4	Overtorque Detection 2	<a href="#">194</a>
<i>EF0</i>	EF0	Option Card External Fault	<a href="#">186</a>	<i>oL5</i>	oL5	Mechanical Weakening Detection 1	<a href="#">194</a>
<i>EF1 to EF8</i>	EF1 to EF8	External Fault (input terminal S1 to S8)	<a href="#">186</a>	<i>oL7</i>	oL7	High Slip Braking oL	<a href="#">194</a>
<i>Err</i>	Err	EEPROM Write Error	<a href="#">187</a>	<i>oPr</i>	oPr	Operator Connection Fault	<a href="#">194</a>
<i>FAn</i>	FAn	Internal Fan Fault	<a href="#">186</a>	<i>oS</i>	oS	Overspeed (for Control Mode with PG)	<a href="#">194</a>
<i>FbH</i>	FbH	Excessive PID Feedback	<a href="#">187</a>	<i>ov</i>	ov	Overvoltage	<a href="#">195</a>
<i>FbL</i>	FbL	PID Feedback Loss	<a href="#">187</a>	<i>PF</i>	PF	Input Phase Loss	<a href="#">196</a>
<i>GF</i>	GF	Ground Fault	<a href="#">187</a>	<i>PGo</i>	PGo	PG Disconnect (for Control Mode with PG)	<a href="#">196</a>
<i>LF</i>	LF	Output Phase Loss	<a href="#">188</a>	<i>PGoH</i>	PGoH	PG Hardware Fault (when using PG-X3)	<a href="#">196</a>
<i>LF2</i>	LF2	Current Imbalance	<a href="#">188</a>	<i>PUF</i>	PUF	Fuse is Open	<a href="#">196</a>
<i>LF3 &lt;S&gt;</i>	LF3	Power Unit Output Phase Loss 3	<a href="#">188</a>	<i>rF</i>	rF	Braking Resistor Fault	<a href="#">196</a>
<i>nSE</i>	nSE	Node Setup Error	<a href="#">188</a>	<i>rH</i>	rH	Dynamic Braking Resistor	<a href="#">197</a>
<i>oC</i>	oC	Overcurrent	<a href="#">189</a>	<i>rr</i>	rr	Dynamic Braking Transistor	<a href="#">197</a>
<i>oFAR00</i>	oFA00	Option Card Connection Error (CN5-A)	<a href="#">190</a>	<i>SC &lt;S&gt;</i>	SC	IGBT Short Circuit or Ground Fault	<a href="#">197</a>

Digital Operator Display		Name	Page
SEr	SEr	Too Many Speed Search Restarts	197
SvE	SvE	Zero-Servo Fault	197
THo <3>	THo	Thermistor Disconnect	197
UL3	UL3	Undertorque Detection 1	198
UL4	UL4	Undertorque Detection 2	198
UL5	UL5	Mechanical Weakening Detection 2	198
UnbC <3>	UnbC	Current Unbalance	198

Digital Operator Display		Name	Page
Uv1	Uv1	Undervoltage	198
Uv2	Uv2	Control Power Supply Undervoltage	199
Uv3	Uv3	Soft Charge Circuit Fault	199
Uv4 <3>	Uv4	Gate Drive Board Undervoltage	199
Uv5	Uv5	MC/FAN power malfunction	199
voF	voF	Output Voltage Detection Fault	200

- <1> Displayed as  $\llbracket PFD0 \rrbracket$  when occurring at drive power up. When one of the faults occurs after successfully starting the drive, the display will show  $\llbracket PFD1 \rrbracket$ .
- <2> Displayed as  $\llbracket PFD2 \rrbracket$  when occurring at drive power up. When one of the faults occurs after successfully starting the drive, the display will show  $\llbracket PFD1 \rrbracket$ .
- <3> Detected in models CIMR-A□4A0930 and 4A1200.
- <4> Available in drive software versions 1015 and later.

**Minor Faults and Alarms**

Refer to [Table 2.6](#) for an overview of possible alarm codes. Conditions such as overvoltages can trip faults and alarms. It is important to distinguish between faults and alarms to determine the proper corrective actions.

When the drive detects an alarm, the ALM indicator LED blinks and the alarm code display flashes. Most alarms trigger a digital output programmed for alarm output (H2-□□ = 10). A fault (not an alarm) is present if the ALM LED lights without blinking. [Refer to Faults on page 177](#) for information on fault codes.

**Table 2.6 Minor Fault and Alarm Displays**

Digital Operator Display		Name	Minor Fault Output (H2-□□ = 10)	Page	Digital Operator Display		Name	Minor Fault Output (H2-□□ = 10)	Page
AEr	AEr	SI-T Station Number Setting Error (CC-Link, CANopen, MECHATROLINK-II)	YES	201	HcA	HcA	Current Alarm	YES	205
bb	bb	Drive Baseblock	No output	201	LT-1	LT-1	Cooling Fan Maintenance Time	No output <1>	205
boL	boL	Braking Transistor Overload Fault	YES	201	LT-2	LT-2	Capacitor Maintenance Time	No output <1>	205
bUS	bUS	Option Card Communications Error	YES	201	LT-3	LT-3	Soft Charge Bypass Relay Maintenance Time	No output <1>	205
CALL	CALL	Serial Communication Transmission Error	YES	202	LT-4	LT-4	IGBT Maintenance Time (50%)	No output <1>	205
CE	CE	MEMOBUS/Modbus Communication Error	YES	202	oH	oH	Heatsink Overheat	YES	206
CrST	CrST	Cannot Reset	YES	202	oH2	oH2	Drive Overheat	YES	206
dEv	dEv	Excessive Speed Deviation (for Control Mode with PG)	YES	202	oH3	oH3	Motor Overheat	YES	206
dFAn	dFAn	Abnormal Diode Module Fan	YES	203	oH5 <2>	oH5	Motor Overheat (NTC Input)	YES	206
dnE	dnE	Drive Disabled	YES	203	oL3	oL3	Overtorque 1	YES	207
dWAL	dWAL	DriveWorksEZ Alarm	YES	186	oL4	oL4	Overtorque 2	YES	207
E5	E5	SI-T3 Watchdog Timer Error	YES	186	oL5	oL5	Mechanical Weakening Detection 1	YES	207
EF	EF	Run Command Input Error	YES	203	oS	oS	Overspeed (for Control Mode with PG)	YES	207
EFAn	EFAn	Abnormal Panel Fan	YES	203	ov	ov	Overvoltage	YES	207
EF0	EF0	Option Card External Fault	YES	203	PASS	PASS	MEMOBUS/Modbus Test Mode Complete	No output	208
EF1 to EF8	EF1 to EF8	External Fault (input terminal S1 to S8)	YES	203	PGo	PGo	PG Disconnect (for Control Mode with PG)	YES	208
FbH	FbH	Excessive PID Feedback	YES	204	PGoH	PGoH	PG Hardware Fault (when using PG-X3)	YES	208
FbL	FbL	PID Feedback Loss	YES	204					
Hbb	Hbb	Safe Disable Signal Input <3>	YES	204					
HbbF	HbbF	Safe Disable Signal Input <3>	YES	204					

## 2.3 Drive Alarms, Faults, and Errors

Digital Operator Display		Name	Minor Fault Output (H2-□□ = 10)	Page
rUn	rUn	During Run 2, Motor Switch Command Input	YES	208
SE	SE	MEMOBUS/Modbus Test Mode Fault	YES	208
THo	THo	Thermistor Disconnect	YES	208
TrPC	TrPC	IGBT Maintenance Time (90%)	YES	208

Digital Operator Display		Name	Minor Fault Output (H2-□□ = 10)	Page
UL3	UL3	Undertorque 1	YES	209
UL4	UL4	Undertorque 2	YES	209
UL5	UL5	Mechanical Weakening Detection 2	YES	198
Uv	Uv	Undervoltage	YES	209
voF	voF	Output Voltage Detection Fault	YES	209

<1> Output when H2-□□ = 2F.

<2> Detected in models CIMR-A□4A0930, 4A1200 and A1000 HHP.

<3> Terminals H1, H2, DM+, and DM- on 600 V class models are designed to the functionality, but are not certified to EN61800-5-1, ISO13849 Cat. 3, IEC/EN61508 SIL2, Insulation coordination: class 1.

### ■ Operation Errors

Table 2.7 Operation Error Displays

Digital Operator Display		Name	Page
oPE01	oPE01	Drive Unit Setting Error	210
oPE02	oPE02	Parameter Setting Range Error	210
oPE03	oPE03	Multi-Function Input Setting Error	210
oPE04	oPE04	Terminal Board Mismatch Error	211
oPE05	oPE05	Run Command Selection Error	211
oPE06	oPE06	Control Method Selection Error	211
oPE07	oPE07	Multi-Function Analog Input Selection Error	211
oPE08	oPE08	Parameter Selection Error	212

Digital Operator Display		Name	Page
oPE09	oPE09	PID Control Selection Error	212
oPE10	oPE10	V/f Data Setting Error	212
oPE11	oPE11	Carrier Frequency Setting Error	213
oPE13	oPE13	Pulse Train Monitor Selection Error	213
oPE15	oPE15	Torque Control Setting Error	213
oPE16	oPE16	Energy Saving Constants Error	213
oPE18	oPE18	Online Tuning Parameter Setting Error	213

### ■ Auto-Tuning Errors

Table 2.8 Auto-Tuning Error Displays

Digital Operator Display		Name	Page
End1	End1	Excessive V/f Setting	214
End2	End2	Motor Iron Core Saturation Coefficient Error	214
End3	End3	Rated Current Setting Alarm	214
End4	End4	Adjusted Slip Value Fell Below Lower Limit	214
End5	End5	Resistance Between Lines Error	214
End6	End6	Leakage Inductance Alarm	214
End7	End7	No-Load Current Alarm	215
Er-01	Er-01	Motor Data Error	215
Er-02	Er-02	Alarm	215
Er-03	Er-03	STOP Button Input	215
Er-04	Er-04	Line-to-Line Resistance Error	215
Er-05	Er-05	No-Load Current Error	215
Er-08	Er-08	Rated Slip Error	216

Digital Operator Display		Name	Page
Er-09	Er-09	Acceleration Error	216
Er-10	Er-10	Motor Direction Error	216
Er-11	Er-11	Motor Speed Error	216
Er-12	Er-12	Current Detection Error	216
Er-13	Er-13	Leakage Inductance Error	217
Er-14	Er-14	Motor Speed Error 2	217
Er-15	Er-15	Torque Saturation Error	217
Er-16	Er-16	Inertia ID Error	217
Er-17	Er-17	Reverse Prohibited Error	217
Er-18	Er-18	Induction Voltage Error	217
Er-19	Er-19	PM Inductance Error	217
Er-20	Er-20	Stator Resistance Error	217
Er-21	Er-21	Z Pulse Correction Error	218

### ■ Errors and Displays When Using the Copy Function

Table 2.9 Copy Errors

Digital Operator Display		Name	Page
CoPy	CoPy	Writing parameter settings (flashing)	219

Digital Operator Display		Name	Page
CPEr	CPEr	Control mode mismatch	219

Digital Operator Display		Name	Page
<i>CPyE</i>	CPyE	Error writing data	<a href="#">219</a>
<i>CSEr</i>	CSEr	Copy unit error	<a href="#">219</a>
<i>dFpS</i>	dFpS	Drive model mismatch	<a href="#">219</a>
<i>End</i>	End	Task complete	<a href="#">219</a>
<i>iFEr</i>	iFEr	Communication error	<a href="#">219</a>
<i>ndAT</i>	ndAT	Model, voltage class, capacity mismatch	<a href="#">220</a>

Digital Operator Display		Name	Page
<i>rdEr</i>	rdEr	Error reading data	<a href="#">220</a>
<i>rEAd</i>	rEAd	Reading parameter settings (flashing)	<a href="#">220</a>
<i>vAEr</i>	vAEr	Voltage class, capacity mismatch	<a href="#">220</a>
<i>vFyE</i>	vFyE	Parameter setting mismatch	<a href="#">220</a>
<i>vrFy</i>	vrFy	Comparing parameter settings (flashing)	<a href="#">220</a>

## 2.4 Fault Detection

### ◆ Fault Displays, Causes, and Possible Solutions

Faults are detected for drive protection, and cause the drive to stop while triggering the fault output terminal MA-MB-MC. Remove the cause of the fault and manually clear the fault before attempting to run the drive again.

**Table 2.10 Detailed Fault Displays, Causes, and Possible Solutions**

Digital Operator Display		Fault Name
<i>boL</i>	boL	Braking Transistor Overload Fault
Cause		Possible Solution
The wrong braking resistor is installed		Select the correct braking resistor.

Digital Operator Display		Fault Name
<i>bUS</i>	bUS	Option Communication Error
Cause		Possible Solution
No signal was received from the PLC		<ul style="list-style-type: none"> <li>• The connection was lost after establishing initial communication.</li> <li>• Only detected when the run command frequency reference is assigned to an option card.</li> </ul>
Faulty communications wiring or an existing short circuit		<ul style="list-style-type: none"> <li>• Check for faulty wiring.</li> <li>• Correct the wiring.</li> <li>• Check for disconnected cables and short circuits and repair as needed.</li> </ul>
Communication data error occurred due to noise		<ul style="list-style-type: none"> <li>• Check the various options available to minimize the effects of noise.</li> <li>• Counteract noise in the control circuit, main circuit, and ground wiring.</li> <li>• Ensure that other equipment such as switches or relays do not cause noise. Use surge absorbers if necessary.</li> <li>• Use only recommended cables or other shielded line. Ground the shield on the controller side or the drive input power side.</li> <li>• Separate all communication wiring from drive power lines. Install an EMC noise filter to the drive power supply input.</li> </ul>
The option card is damaged		Replace the option card if there are no problems with the wiring and the error continues to occur.
The option card is not properly connected to the drive		<ul style="list-style-type: none"> <li>• The connector pins on the option card do not line up properly with the connector pins on the drive.</li> <li>• Reinstall the option card.</li> </ul>

Digital Operator Display		Fault Name
<i>CE</i>	CE	MEMOBUS/Modbus Communication Error
Cause		Possible Solution
Faulty communications wiring or an existing short circuit		<ul style="list-style-type: none"> <li>• Control data was not received for the CE detection time set to H5-09.</li> <li>• Check for faulty wiring.</li> <li>• Correct the wiring.</li> <li>• Check for disconnected cables and short circuits and repair as needed.</li> </ul>
Communication data error occurred due to noise		<ul style="list-style-type: none"> <li>• Check the various options available to minimize the effects of noise.</li> <li>• Counteract noise in the control circuit, main circuit, and ground wiring.</li> <li>• Use only recommended cables or other shielded line. Ground the shield on the controller side or the drive input power side.</li> <li>• Ensure that other equipment such as switches or relays do not cause noise. Use surge suppressors if required.</li> <li>• Separate all communication wiring from drive power lines. Install an EMC noise filter to the drive power supply input.</li> </ul>

Digital Operator Display		Fault Name
<i>CF</i>	CF	Control Fault
Cause		Possible Solution
Motor parameters are set improperly		The torque limit was reached continuously for three seconds or longer while ramping to stop in OLV Control.
Torque limit is too low		Check the motor parameter settings and repeat Auto-Tuning.
		Set the torque limit to the most appropriate setting (L7-01 through L7-04).

Load inertia is too big	<ul style="list-style-type: none"> <li>Adjust the deceleration time (C1-02, C1-04, C1-06, C1-08).</li> <li>Set the frequency to the minimum value and interrupt the Run command when the drive finishes decelerating.</li> </ul>
-------------------------	--

Digital Operator Display		Fault Name
[PF00] or [PF01]	CPF11 to CPF14 CPF16 to CPF19	Control Circuit Error
Cause		Possible Solution
There is a self-diagnostic error in the control circuit		<ul style="list-style-type: none"> <li>Cycle power to the drive.</li> <li>If the problem continues, replace the control board or the entire drive. Contact Yaskawa or a Yaskawa representative for instructions on replacing the control board.</li> </ul>
Connector on the operator is damaged		Replace the operator.

Digital Operator Display		Fault Name
[PF02]	CPF02	A/D Conversion Error
Cause		Possible Solution
Control circuit is damaged		<ul style="list-style-type: none"> <li>Cycle power to the drive.</li> <li>If the problem continues, replace the control board or the entire drive. Contact Yaskawa or a Yaskawa representative for instructions on replacing the control board.</li> </ul>

Digital Operator Display		Fault Name
[PF03]	CPF03	Control Board Connection Error
Cause		Possible Solution
There is a connection error		<ul style="list-style-type: none"> <li>Turn off the power and check the connection between the control board and the drive.</li> <li>If the problem continues, replace the control board or the entire drive. Contact Yaskawa or a Yaskawa representative for instructions on replacing the control board.</li> </ul>
Drive fails to operate properly due to noise interference		<ul style="list-style-type: none"> <li>Check the various options available to minimize the effects of noise.</li> <li>Counteract noise in the control circuit, main circuit, and ground wiring.</li> <li>Use only recommended cables or other shielded line. Ground the shield on the controller side or the drive input power side.</li> <li>Ensure that other equipment such as switches or relays do not cause noise. Use surge suppressors if required.</li> <li>Separate all communication wiring from drive power lines. Install an EMC noise filter to the drive power supply input.</li> </ul>

Digital Operator Display		Fault Name
[PF06]	CPF06	EEPROM Memory Data Error
Cause		Possible Solution
There is an error in EEPROM control circuit		<ul style="list-style-type: none"> <li>Turn off the power and check the connection between the control board and the drive.</li> <li>If the problem continues, replace the control board or the entire drive. Contact Yaskawa or a Yaskawa representative for instructions on replacing the control board.</li> </ul>
The power supply was switched off while parameters were being saved to the drive		Reinitialize the drive using parameter A1-03.

Digital Operator Display		Fault Name
[PF07]	CPF07	Terminal Board Connection Error
[PF08]	CPF08	
Cause		Possible Solution
There is a faulty connection between the terminal board and the control board		<ul style="list-style-type: none"> <li>Turn off the power and check the connection between the control board and the drive.</li> <li>If the problem continues, replace the control board or the entire drive. Contact Yaskawa or a Yaskawa representative for instructions on replacing the control board.</li> </ul>

Digital Operator Display		Fault Name
[PF20] or [PF21]	CPF20 or CPF21	Control Circuit Error
Cause		Possible Solution

## 2.4 Fault Detection

Hardware is damaged	<ul style="list-style-type: none"> <li>• Cycle power to the drive.</li> <li>• If the problem continues, replace the control board or the entire drive. Contact Yaskawa or a Yaskawa representative for instructions on replacing the control board.</li> </ul>
---------------------	--

Digital Operator Display		Fault Name
$\overline{CPF22}$	CPF22	Hybrid IC Failure
<b>Cause</b>		<b>Possible Solution</b>
Hybrid IC failure on the power board		<ul style="list-style-type: none"> <li>• Cycle power to the drive.</li> <li>• If the problem continues, replace the power board or the entire drive. Contact Yaskawa or a Yaskawa representative for instructions on replacing the power board.</li> </ul>

Digital Operator Display		Fault Name
$\overline{CPF23}$	CPF23	Control Board Connection Error
<b>Cause</b>		<b>Possible Solution</b>
Hardware is damaged		<ul style="list-style-type: none"> <li>• Turn off the power and check the connection between the control board and the drive.</li> <li>• If the problem continues, replace the control board or the entire drive. Contact Yaskawa or a Yaskawa representative for instructions on replacing the control board.</li> </ul>

Digital Operator Display		Fault Name
$\overline{CPF24}$	CPF24	Drive Unit Signal Fault
<b>Cause</b>		<b>Possible Solution</b>
Hardware is damaged		<ul style="list-style-type: none"> <li>• The drive capacity cannot be detected correctly (drive capacity is checked when the drive is powered up).</li> <li>• If the problem continues, replace the control board or the entire drive. Contact Yaskawa or a Yaskawa representative for instructions on replacing the control board.</li> </ul>

Digital Operator Display		Fault Name
$\overline{CPF26}$ to $\overline{CPF34}$ $\overline{CPF40}$ to $\overline{CPF45}$	CPF26 to CPF34 CPF40 to CPF45	Control Circuit Error
<b>Cause</b>		<b>Possible Solution</b>
Hardware is damaged		<ul style="list-style-type: none"> <li>• CPU error</li> <li>• If the problem continues, replace the control board or the entire drive. Contact Yaskawa or a Yaskawa representative for instructions on replacing the control board.</li> </ul>

Digital Operator Display		Fault Name
$\overline{dEv}$	dEv	Speed Deviation (for Control Mode with PG)
<b>Cause</b>		<b>Possible Solution</b>
Load is too heavy		Reduce the load.
Acceleration and deceleration times are set too short		Increase the acceleration and deceleration times (C1-01 through C1-08).
The load is locked up		Check the machine.
Parameters are not set appropriately		Check the settings of parameters F1-10 and F1-11.
Incorrect speed feedback scaling when using terminal RP as speed feedback input in V/f control		<ul style="list-style-type: none"> <li>• Set H6-02 to the same value as the speed feedback signal frequency when the motor runs at maximum speed.</li> <li>• Adjust the speed feedback signal using parameters H6-03 through H6-05.</li> <li>• Make sure the speed feedback signal frequency does not exceed the maximum input frequency of terminal RP.</li> </ul>
Motor brake is engaged		Ensure the motor brake releases properly.

Digital Operator Display		Fault Name
$\overline{dFAn}$	dFAn	Abnormal Diode Module Fan
<b>Cause</b>		<b>Possible Solution</b>
		Displays when diode converter module(s) has a fan fault



Diode module cooling fan has malfunctioned.	<ul style="list-style-type: none"> <li>• Cycle power to the drive.</li> <li>• Check for fan operation.</li> <li>• Verify the cumulative operation time of the fan with monitor U4-03, and verify the cumulative operation time of the fan maintenance timer with U4-04.</li> <li>• If the cooling fan has exceeded its expected performance life or is damaged in any other way, replace the cooling fan.</li> </ul>
---	--

Digital Operator Display		Fault Name
<i>du1</i>	dv1	Z Pulse Fault
Cause		Possible Solution
PG encoder is disconnected, improperly wired, or the PG option card or PG encoder are damaged		<ul style="list-style-type: none"> <li>• Make sure the PG encoder is properly connected and all shielded lines are properly grounded.</li> <li>• If the problem continues after cycling power, replace the PG option card or the PG encoder.</li> </ul>

Digital Operator Display		Fault Name
<i>du2</i>	dv2	Z Pulse Noise Fault Detection
Cause		Possible Solution
Noise interference along the PG cable		Separate the PG cable lines from the source of the noise.
PG cable is not wired properly		Rewire the PG encoder and properly ground all shielded lines.
PG option card or the PG encoder are damaged		If the problem continues after cycling power, replace the PG option card or the PG encoder.

Digital Operator Display		Fault Name
<i>du3</i>	dv3	Inversion Detection
Cause		Possible Solution
The Z Pulse offset is not set properly to E5-11		Set the value for $\Delta\theta$ to E5-11 as specified on the motor nameplate. Readjust the Z Pulse offset when replacing the PG encoder or changing the application to rotate the motor in reverse.
An external force on the load side caused the motor to move		<ul style="list-style-type: none"> <li>• Make sure the motor is rotating in the proper direction.</li> <li>• Identify and fix any problems on the load side causing the motor to rotate in the opposite direction.</li> </ul>
Noise interference along the PG cable affecting the A or B pulse		Properly rewire the PG encoder and connect all lines including shielded line.
PG encoder is disconnected, improperly wired, or the PG option card or PG encoder are damaged		
Rotational direction for the PG encoder set to F1-05 is the opposite of the motor line order		Properly connect the motor lines for each phase (U, V, W).

Digital Operator Display		Fault Name
<i>du4</i>	dv4	Inversion Prevention Detection
Cause		Possible Solution
The Z Pulse offset is not set properly to E5-11		<ul style="list-style-type: none"> <li>• Set the value for <math>\Delta\theta</math> to E5-11 as specified on the motor nameplate.</li> <li>• If the problem continues after cycling power, replace the PG option card or the PG encoder. Readjust the Z Pulse offset when replacing the PG encoder or changing the application to rotate the motor in reverse.</li> </ul>
Noise interference along the PG cable affecting the A or B pulse		<ul style="list-style-type: none"> <li>• Make sure the motor is rotating in the proper direction.</li> <li>• Identify and fix any problems on the load side causing the motor to rotate in the opposite direction.</li> </ul>
PG encoder is disconnected, improperly wired, or the PG option card or PG encoder are damaged		<ul style="list-style-type: none"> <li>• Rewire the PG encoder and properly connect all lines including shielded line.</li> <li>• If the problem continues after cycling power, replace the PG option card or the PG encoder.</li> </ul>

## 2.4 Fault Detection

Digital Operator Display		Fault Name
<i>dWAL</i>	dWAL	DriveWorksEZ Fault
<i>dWFL</i>	dWFL	
Cause		Possible Solution
Fault output by DriveWorksEZ		Correct the cause of the fault.

Digital Operator Display		Fault Name
<i>E5</i>	E5	SI-T3 Watchdog Timer Error
		The watchdog timed out.
Cause		Possible Solution
Data has not been received from the PLC		Execute DISCONNECT or ALM_CLR, then issue a CONNECT command or SYNC_SET command and proceed to phase 3. Refer to the SI-T3 Option Technical Manual for more details on troubleshooting.

Digital Operator Display		Fault Name
<i>EFA<sub>n</sub></i>	EFA <sub>n</sub>	Abnormal Panel Fan
		Displays when the Panel Fan Control detects a fan fault
Cause		Possible Solution
Panel fan or panel fan control has malfunctioned		<ul style="list-style-type: none"> <li>• Cycle power to the drive.</li> <li>• Check for fan operation.</li> <li>• Verify the cumulative operation time of the fan with monitor U4-03, and verify the cumulative operation time of the fan maintenance timer with U4-04.</li> <li>• If the cooling fan has exceeded its expected performance life or is damaged in any other way, replace the cooling fan.</li> </ul>

Digital Operator Display		Fault Name
<i>EF0</i>	EF0	Option Card External Fault
		An external fault condition is present.
Cause		Possible Solution
An external fault was received from the PLC and F6-03 is set to a value other than 3.		<ul style="list-style-type: none"> <li>• Remove the cause of the external fault.</li> <li>• Remove the external fault input from the PLC.</li> </ul>
Problem with the PLC program		Check the PLC program and correct problems.

Digital Operator Display		Fault Name
<i>EF1</i>	EF1	External Fault (input terminal S1)
		External fault at multi-function input terminal S1.
<i>EF2</i>	EF2	External Fault (input terminal S2)
		External fault at multi-function input terminal S2.
<i>EF3</i>	EF3	External Fault (input terminal S3)
		External fault at multi-function input terminal S3.
<i>EF4</i>	EF4	External Fault (input terminal S4)
		External fault at multi-function input terminal S4.
<i>EF5</i>	EF5	External Fault (input terminal S5)
		External fault at multi-function input terminal S5.
<i>EF6</i>	EF6	External Fault (input terminal S6)
		External fault at multi-function input terminal S6.
<i>EF7</i>	EF7	External Fault (input terminal S7)
		External fault at multi-function input terminal S7.
<i>EF8</i>	EF8	External Fault (input terminal S8)
		External fault at multi-function input terminal S8.
Cause		Possible Solution
An external device tripped an alarm function		Remove the cause of the external fault and reset the fault.
Wiring is incorrect		<ul style="list-style-type: none"> <li>• Properly connect the signal lines to the terminals assigned for external fault detection (H1-□□ = 20 to 2F).</li> <li>• Reconnect the signal line.</li> </ul>

Multi-function contact input setting is incorrect		<ul style="list-style-type: none"> <li>• Check for unused terminals set for H1-□□ = 20 to 2F (External Fault).</li> <li>• Change the terminal settings.</li> </ul>
---	--	--

Digital Operator Display		Fault Name
<i>Err</i>	Err	EEPROM Write Error
		Data cannot be written to the EEPROM
<b>Cause</b>		<b>Possible Solution</b>
Noise has corrupted data while writing to the EEPROM		<ul style="list-style-type: none"> <li>• Press “ENTER” on the digital operator.</li> <li>• Correct the parameter setting.</li> <li>• Cycle power to the drive.</li> <li>• If the problem continues, replace the control board or the entire drive. Contact Yaskawa or a Yaskawa representative for instructions on replacing the control board.</li> </ul>
Hardware problem		If the problem continues, replace the control board or the entire drive. Contact Yaskawa or a Yaskawa representative for instructions on replacing the control board.

Digital Operator Display		Fault Name
<i>FAn</i>	FAn	Internal Fan Fault
		Fan or magnetic contactor failure
<b>Cause</b>		<b>Possible Solution</b>
Internal cooling fan has malfunctioned		<ul style="list-style-type: none"> <li>• Cycle power to the drive.</li> <li>• Check for fan operation.</li> <li>• Verify the cumulative operation time of the fan with monitor U4-03, and verify the cumulative operation time of the fan maintenance timer with U4-04.</li> <li>• If the cooling fan has exceeded its expected performance life or is damaged in any other way, replace the cooling fan.</li> </ul>
Fault detected in the internal cooling fan or magnetic contactor to the power supply.		<ul style="list-style-type: none"> <li>• Cycle power to the drive.</li> <li>• If the fault continues to occur, replace the power board/gate drive board or the entire drive.</li> <li>• Contact Yaskawa or a Yaskawa representative for instructions on replacing the power board/gate drive board.</li> </ul>

Digital Operator Display		Fault Name
<i>FbH</i>	FbH	Excessive PID Feedback
		PID feedback input is greater than the level set to b5-36 for longer than the time set to b5-37. Set b5-12 to 2 or 5 to enable fault detection.
<b>Cause</b>		<b>Possible Solution</b>
Parameters are set inappropriately		Check b5-36 and b5-37 settings.
Incorrect PID feedback wiring		Correct the wiring.
There is a problem with the feedback sensor		<ul style="list-style-type: none"> <li>• Check the sensor on the control side.</li> <li>• Replace the sensor if damaged.</li> </ul>

Digital Operator Display		Fault Name
<i>FbL</i>	FbL	PID Feedback Loss
		This fault occurs when PID feedback loss detection is programmed to trigger a fault (b5-12 = 2) and the PID feedback level is below the detection level set to b5-13 for longer than the time set to b5-14.
<b>Cause</b>		<b>Possible Solution</b>
Parameters are set inappropriately		Check b5-13 and b5-14 settings.
Incorrect PID feedback wiring		Correct the wiring.
There is a problem with the feedback sensor		<ul style="list-style-type: none"> <li>• Check the sensor on the control side.</li> <li>• Replace the sensor if damaged.</li> </ul>

Digital Operator Display		Fault Name
<i>GF</i>	GF	Ground Fault
		<ul style="list-style-type: none"> <li>• A current short to ground exceeded 50% of rated current on the output side of the drive.</li> <li>• Setting L8-09 to 1 enables ground fault detection.</li> </ul>
<b>Cause</b>		<b>Possible Solution</b>

## 2.4 Fault Detection

Motor insulation is damaged	<ul style="list-style-type: none"> <li>• Check the insulation resistance of the motor.</li> <li>• Replace the motor.</li> </ul>
A damaged motor cable is creating a short circuit	<ul style="list-style-type: none"> <li>• Check the motor cable.</li> <li>• Remove the short circuit and reapply power to the drive</li> <li>• Check the resistance between the cable and the ground terminal ⊕.</li> <li>• Replace the cable.</li> </ul>
Excessive leakage current at the drive output	<ul style="list-style-type: none"> <li>• Reduce the carrier frequency.</li> <li>• Reduce the amount of stray capacitance.</li> </ul>
The drive started to run during a current offset fault or while coasting to a stop	<ul style="list-style-type: none"> <li>• The set value exceeds the allowable setting range while the drive automatically adjusts the current offset. This only happens when attempting to restart a PM motor that is coasting to stop.</li> <li>• Set b3-01 to 1 to enable Speed Search at Start.</li> <li>• Perform Speed Search 1 or 2 (H1-□□ = 61 or 62) via one of the external terminals.</li> </ul> <p><b>Note:</b> Speed Searches 1 and 2 are the same when using OLV/PM.</p>
Hardware problem	If the problem continues, replace the control board or the entire drive. Contact Yaskawa or a Yaskawa representative for instructions on replacing the control board.

Digital Operator Display		Fault Name
LF	LF	Output Phase Loss
		<ul style="list-style-type: none"> <li>• Phase loss on the output side of the drive.</li> <li>• Setting L8-07 to 1 or 2 enables Phase Loss Detection.</li> </ul>
<b>Cause</b>		<b>Possible Solution</b>
The output cable is disconnected		<ul style="list-style-type: none"> <li>• Check for wiring errors and properly connect the output cable.</li> <li>• Correct the wiring.</li> </ul>
The motor winding is damaged		<ul style="list-style-type: none"> <li>• Check the resistance between motor lines.</li> <li>• Replace the motor if the winding is damaged.</li> </ul>
The output terminal is loose		<ul style="list-style-type: none"> <li>• Check for loose terminals.</li> </ul>
The rated current of the motor being used is less than 5% of the drive rated current		Check the drive and motor capacities.
An output transistor is damaged		If the problem continues, replace the control board or the entire drive. Contact Yaskawa or a Yaskawa representative for instructions on replacing the control board.
A single-phase motor is being used		The drive cannot operate a single phase motor.

Digital Operator Display		Fault Name
LF2	LF2	Output Current Imbalance
		One or more of the phases in the output current are lost.
<b>Cause</b>		<b>Possible Solution</b>
Phase loss has occurred on the output side of the drive		<ul style="list-style-type: none"> <li>• Check for faulty wiring or poor connections on the output side of the drive.</li> <li>• Correct the wiring.</li> </ul>
Terminal wires are loose on the output side of the drive		Check for loose terminals.
The output circuit is damaged		If the problem continues, replace the control board or the entire drive. Contact Yaskawa or a Yaskawa representative for instructions on replacing the control board.
Motor impedance or motor phases are uneven		<ul style="list-style-type: none"> <li>• Measure the line-to-line resistance for each motor phase. Ensure all values match.</li> <li>• Replace the motor.</li> </ul>

Digital Operator Display		Fault Name
LF3	LF3	Power Unit Output Phase Loss 3
		<ul style="list-style-type: none"> <li>• Phase loss occurred on the output side</li> <li>• Setting L8-78 to 1 enables Power Unit Output Phase Loss Protection</li> </ul>
<b>Cause</b>		<b>Possible Solution</b>
The gate drive board in the power unit is damaged.		Cycle the power supply. <i>Refer to Diagnosing and Resetting Faults on page 221</i> for details. If the fault continues to occur, replace the gate drive board or the entire drive. Contact Yaskawa or a Yaskawa representative for instructions on replacing the gate drive board.
Cable to the current detection circuit in the power unit is damaged or not connected properly.		Check for incorrect wiring and correct any wiring mistakes.

Cable between the output reactor and the power unit is loose or not connected.	Contact Yaskawa or your nearest sales representative for instructions.
--	--

Digital Operator Display		Fault Name
n5E	nSE	Node Setup Error
		A terminal assigned to the node setup function closed during run.
Cause		Possible Solution
The node setup terminal closed during run.		Stop the drive when using the node setup function.
A Run command was issued while the node setup function was active.		

Digital Operator Display		Fault Name
oC	oC	Overcurrent
		Drive sensors detected an output current greater than the specified overcurrent level.
Cause		Possible Solution
The motor has been damaged due to overheating or the motor insulation is damaged		<ul style="list-style-type: none"> <li>Check the insulation resistance.</li> <li>Replace the motor.</li> </ul>
One of the motor cables has shorted out or there is a grounding problem		<ul style="list-style-type: none"> <li>Check the motor cables.</li> <li>Remove the short circuit and reapply power to the drive.</li> <li>Check the resistance between the motor cables and the ground terminal ⊕.</li> <li>Replace damaged cables.</li> </ul>
The load is too heavy		<ul style="list-style-type: none"> <li>Measure the current flowing into the motor.</li> <li>Replace the drive with a larger capacity drive if the current value exceeds the rated current.</li> <li>Determine if there is sudden fluctuation in the current level.</li> <li>Reduce the load to avoid sudden changes in the current level or switch to a larger drive.</li> </ul>
The acceleration or deceleration times are too short		<p>Calculate the torque needed during acceleration relative to the load inertia and the specified acceleration time. If it is not possible to set the proper amount of torque, make the following changes:</p> <ul style="list-style-type: none"> <li>Increase the acceleration time (C1-01, C1-03, C1-05, C1-07)</li> <li>Increase the S-curve characteristics (C2-01 through C2-04)</li> <li>Increase the capacity of the drive.</li> </ul>
The drive is attempting to operate a specialized motor or a motor larger than the maximum size allowed		<ul style="list-style-type: none"> <li>Check the motor capacity.</li> <li>Ensure that the rated capacity of the drive is greater than or equal to the capacity rating found on the motor nameplate.</li> </ul>
Magnetic contactor (MC) on the output side of the drive has turned on or off		Set up the operation sequence so the MC does not trip while the drive is outputting current.
V/f setting is not operating as expected		<ul style="list-style-type: none"> <li>Check the ratios between the voltage and frequency.</li> <li>Set parameters E1-04 through E1-10 appropriately (E3-04 through E3-10 for motor 2).</li> <li>Lower the voltage if it is too high relative to the frequency.</li> </ul>
Excessive torque compensation		<ul style="list-style-type: none"> <li>Check the amount of torque compensation.</li> <li>Reduce the torque compensation gain (C4-01) until there is no speed loss and less current.</li> </ul>
Drive fails to operate properly due to noise interference		<ul style="list-style-type: none"> <li>Review the possible solutions provided for handling noise interference.</li> <li>Review the section on handling noise interference on page 228 and check the control circuit lines, main circuit lines, and ground wiring.</li> </ul>
Overexcitation gain is set too high		<ul style="list-style-type: none"> <li>Check if the fault occurs simultaneously with overexcitation function operation.</li> <li>Consider motor flux saturation and reduce the value of n3-13 (Overexcitation Deceleration Gain).</li> </ul>
Run command was applied while motor was coasting		<ul style="list-style-type: none"> <li>Set b3-01 to 1 to enable Speed Search at Start.</li> <li>Program the Speed Search command input through one of the multi-function contact input terminals (H1-□□ = 61 or 62).</li> </ul>
The motor control method and motor do not match		<ul style="list-style-type: none"> <li>Check the control mode.</li> <li>For IM motors, set A1-02 to 0, 1, 2, or 3.</li> <li>For PM motors, set A1-02 to 5, 6, or 7.</li> </ul>
The rated output current of the drive is too small		Use a larger drive.

## 2.4 Fault Detection

Digital Operator Display		Fault Name
<i>oFR00</i>	oFA00	Option Card Connection Error at Option Port CN5-A
		Option compatibility error
<b>Cause</b>		<b>Possible Solution</b>
The option card installed into port CN5-A is incompatible with the drive		Check if the drive supports the option card to be installed. Contact Yaskawa for assistance.
A PG option card is connected to option port CN5-A		PG option cards are supported by option ports CN5-B and CN5-C only. Connect the PG option card to the correct option port.

Digital Operator Display		Fault Name
<i>oFR01</i>	oFA01	Option Card Fault at Option Port CN5-A
		Option not properly connected
<b>Cause</b>		<b>Possible Solution</b>
The option card connection to port CN5-A is faulty		<ul style="list-style-type: none"> <li>Turn off the power and reconnect the option card.</li> <li>Check if the option card is properly plugged into the option port. Make sure the card is fixed properly.</li> <li>If the option is not a communication option card, try to use the card in a different option port. If the option card works properly in a different option port, CN5-A is damaged, and the drive requires replacement. If the error persists (oFb01 or oFC01 occur), replace the option card.</li> </ul>

Digital Operator Display		Fault Name
<i>oFR03 to oFR06</i>	oFA03 to oFA06	Option Card Error Occurred at Option Port CN5-A
<i>oFR10, oFR11</i>	oFA10, oFA11	
<i>oFR12 to oFR17</i>	oFA12 to oFA17	Option Card Connection Error (CN5-A)
<i>oFR30 to oFR43</i>	oFA30 to oFA43	Communication Option Card Connection Error (CN5-A)
<b>Cause</b>		<b>Possible Solution</b>
Option card or hardware is damaged		<ul style="list-style-type: none"> <li>Cycle power to the drive.</li> <li>If the problem continues, replace the control board or the entire drive. Contact Yaskawa or a Yaskawa representative for instructions on replacing the control board.</li> </ul>

Digital Operator Display		Fault Name
<i>oFb00</i>	oFb00	Option Card Fault at Option Port CN5-B
		Option compatibility error
<b>Cause</b>		<b>Possible Solution</b>
The option card installed into port CN5-B is incompatible with the drive		Make sure the drive supports the option card to be installed. Contact Yaskawa for assistance.
A communication option card has been installed in option port CN5-B		Communication option cards are only supported by option port CN5-A. It is not possible to install more than one communication option.

Digital Operator Display		Fault Name
<i>oFb01</i>	oFb01	Option Card Fault at Option Port CN5-B
		Option not properly connected
<b>Cause</b>		<b>Possible Solution</b>
The option card connection to port CN5-B is faulty		<ul style="list-style-type: none"> <li>Turn off the power and reconnect the option card.</li> <li>Check if the option card is properly plugged into the option port. Make sure the card is fixed properly.</li> <li>Try to use the card in a different option port (in case of a PG option, use port CN5-C). If the option card works properly in a different option port, CN5-B is damaged, and the drive requires replacement. If the error persists (oFA01 or oFC01 occur), replace the option card.</li> </ul>

Digital Operator Display		Fault Name
<i>oFb02</i>	oFb02	Option Card Fault at Option Port CN5-B
		Same type of option card is currently connected
<b>Cause</b>		<b>Possible Solution</b>
An option card of the same type is already installed in option port CN5-A		Except for PG options, only one of each option card type can only be installed simultaneously. Make sure only one type of option card is connected.
An input option card is already installed in option port CN5-A		Install a communication option, a digital input option, or an analog input option. More than one of the same type of card cannot be installed simultaneously.

Digital Operator Display		Fault Name
oFb03 to oFb11	oFb03 to oFb11	Option card error occurred at Option Port CN5-B
oFb12 to oFb17	oFb12 to oFb17	
Cause		Possible Solution
Option card or hardware is damaged		<ul style="list-style-type: none"> <li>• Cycle power to the drive.</li> <li>• If the problem continues, replace the control board or the entire drive. Contact Yaskawa or a Yaskawa representative for instructions on replacing the control board.</li> </ul>

Digital Operator Display		Fault Name
oFC00	oFC00	Option Card Connection Error at Option Port CN5-C
Cause		Option compatibility error
Possible Solution		
The option card installed into port CN5-C is incompatible with the drive		Confirm that the drive supports the option card to be installed. Contact Yaskawa for assistance.
A communication option card has been installed in option port CN5-C		Communication option cards are only supported by option port CN5-A. It is not possible to install more than one communication option.

Digital Operator Display		Fault Name
oFC01	oFC01	Option Card Fault at Option Port CN5-C
Cause		Option not properly connected
Possible Solution		
The option card connection to port CN5-C is faulty.		<ul style="list-style-type: none"> <li>• Turn the power off and reconnect the option card.</li> <li>• Check if the option card is properly plugged into the option port. Make sure the card is fixed properly.</li> <li>• Try to use the card in a different option port (in case of a PG option, use port CN5-B). If the option card works properly in a different option port, CN5-C is damaged, and the drive requires replacement. If the error persists (oFA01 or oFb01 occur), replace the option card.</li> </ul>

Digital Operator Display		Fault Name
oFC02	oFC02	Option Card Fault at Option Port CN5-C
Cause		Same type of option card is currently connected
Possible Solution		
An option card of the same type is already installed in option port CN5-A or CN5-B.		Except for PG options, only one of each option card type can only be installed simultaneously. Make sure only one type of option card is connected.
An input option card is already installed in option port CN5-A or CN5-B.		Install a communication option, a digital input option, or an analog input option. More than one of the same type of card cannot be installed simultaneously.
Three PG option boards are installed.		A maximum of two PG option boards can be used simultaneously. Remove the PG option board installed into option port CN5-A.

Digital Operator Display		Fault Name
oFC03 to oFC11	oFC03 to oFC11	Option Card Error Occurred at Option Port CN5-C
oFC12 to oFC17	oFC12 to oFC17	
Cause		Possible Solution
Option card or hardware is damaged		<ul style="list-style-type: none"> <li>• Cycle power to the drive.</li> <li>• If the problem continues, replace the control board or the entire drive. Contact Yaskawa or a Yaskawa representative for instructions on replacing the control board.</li> </ul>

Digital Operator Display		Fault Name
oH	oH	Heatsink Overheat
Cause		The heatsink temperature exceeded the overheat pre-alarm level set to L8-02. The default value for L8-02 is determined by drive capacity (o2-04).
Possible Solution		
Surrounding temperature is too high		<ul style="list-style-type: none"> <li>• Check the temperature surrounding the drive. Verify temperature is within drive specifications.</li> <li>• Improve the air circulation within the enclosure panel.</li> <li>• Install a fan or air conditioner to cool the surrounding area.</li> <li>• Remove anything near the drive that might be producing excessive heat.</li> </ul>

## 2.4 Fault Detection

Load is too heavy	<ul style="list-style-type: none"> <li>• Measure the output current.</li> <li>• Decrease the load.</li> <li>• Lower the carrier frequency (C6-02).</li> </ul>
Internal cooling fan is stopped	<ul style="list-style-type: none"> <li>• Replace the cooling fan.</li> <li>• After replacing the cooling fan, set parameter o4-03 to 0 to reset the cooling fan maintenance.</li> </ul>

Digital Operator Display		Fault Name
oH1	oH1	Overheat 1 (Heatsink Overheat)
		The heatsink temperature exceeded the drive overheat level. Overheat level is determined by drive capacity (o2-04).
<b>Cause</b>		<b>Possible Solution</b>
Surrounding temperature is too high		<ul style="list-style-type: none"> <li>• Check the temperature surrounding the drive.</li> <li>• Improve the air circulation within the enclosure panel.</li> <li>• Install a fan or air conditioner to cool the surrounding area.</li> <li>• Remove anything near the drive that might be producing excessive heat.</li> </ul>
Load is too heavy		<ul style="list-style-type: none"> <li>• Measure the output current.</li> <li>• Lower the carrier frequency (C6-02).</li> <li>• Reduce the load.</li> </ul>

Digital Operator Display		Fault Name
oH3	oH3	Motor Overheat Alarm (PTC Input)
		<ul style="list-style-type: none"> <li>• The motor overheat signal to analog input terminal A1, A2, or A3 exceeded the alarm detection level.</li> <li>• Detection requires setting multi-function analog inputs H3-02, H3-06, or H3-10 to E.</li> </ul>
<b>Cause</b>		<b>Possible Solution</b>
Motor has overheated		<ul style="list-style-type: none"> <li>• Check the size of the load, the accel/decel times, and the cycle times.</li> <li>• Decrease the load.</li> <li>• Increase the acceleration and deceleration times (C1-01 through C1-08).</li> </ul>
		<ul style="list-style-type: none"> <li>• Adjust the preset V/f pattern (E1-04 through E1-10) by reducing E1-08 and E1-10.</li> <li>• Do not set E1-08 and E1-10 too low. This reduces load tolerance at low speeds.</li> </ul>
		<ul style="list-style-type: none"> <li>• Check the motor rated current.</li> <li>• Enter the motor rated current to parameter E2-01 as indicated on the motor nameplate.</li> <li>• Ensure the motor cooling system is operating normally.</li> </ul>
		<ul style="list-style-type: none"> <li>• Repair or replace the motor cooling system.</li> </ul>

Digital Operator Display		Fault Name
oH4	oH4	Motor Overheat Fault (PTC Input)
		<ul style="list-style-type: none"> <li>• The motor overheat signal to analog input terminal A1, A2, or A3 exceeded the fault detection level.</li> <li>• Detection requires setting multi-function analog inputs H3-02, H3-06, or H3-10 to E.</li> </ul>
<b>Cause</b>		<b>Possible Solution</b>
Motor has overheated		<ul style="list-style-type: none"> <li>• Check the size of the load, the accel/decel times, and the cycle times.</li> <li>• Decrease the load.</li> <li>• Increase the acceleration and deceleration times (C1-01 through C1-08).</li> </ul>
		<ul style="list-style-type: none"> <li>• Adjust the preset V/f pattern (E1-04 through E1-10) by reducing E1-08 and E1-10.</li> <li>• Do not set E1-08 and E1-10 too low. This reduces load tolerance at low speeds.</li> </ul>
		<ul style="list-style-type: none"> <li>• Check the motor rated current.</li> <li>• Enter the motor rated current to parameter E2-01 as indicated on the motor nameplate.</li> <li>• Ensure the motor cooling system is operating normally.</li> </ul>
		<ul style="list-style-type: none"> <li>• Repair or replace the motor cooling system.</li> </ul>

Digital Operator Display		Fault Name
oH5	oH5	Motor Overheat (NTC Input)
		The motor temperature exceeded the level set to L1-16 (or L1-18 for motor 2)
<b>Cause</b>		<b>Possible Solution</b>
Motor has overheated		<ul style="list-style-type: none"> <li>• Reduce the load.</li> <li>• Check the ambient temperature.</li> </ul>



Digital Operator Display		Fault Name
<i>oHb</i>	oH6	Converter Heating
		Displays when a Diode Converter Module(s) have a heat sink overtemperature
Cause		Possible Solution
Surrounding temperature of converter heatsink is too high.		<ul style="list-style-type: none"> <li>• Check the temperature surrounding the drive. Verify temperature is within drive specifications.</li> <li>• Improve the air circulation within the enclosure panel.</li> <li>• Install a fan or air conditioner to cool the surrounding area.</li> <li>• Remove anything near the drive that might be producing excessive heat.</li> </ul>

Digital Operator Display		Fault Name
<i>oL1</i>	oL1	Motor Overload
		The electronic motor overload protection tripped
Cause		Possible Solution
Load is too heavy		Reduce the load.
Cycle times are too short during acceleration and deceleration		Increase the acceleration and deceleration times (C1-01 through C1-08).
A general-purpose motor is driven below the rated speed with a high load		<ul style="list-style-type: none"> <li>• Reduce the load.</li> <li>• Increase the speed.</li> <li>• If the motor is supposed to operate at low speeds, either increase the motor capacity or use a motor specifically designed to operate in the desired speed range.</li> </ul>
The output voltage is too high		<ul style="list-style-type: none"> <li>• Adjust the user-set V/f pattern (E1-04 through E1-10) by reducing E1-08 and E1-10.</li> <li>• Do not set E1-08 and E1-10 too low. This reduces load tolerance at low speeds.</li> </ul>
The wrong motor rated current is set to E2-01		<ul style="list-style-type: none"> <li>• Check the motor-rated current.</li> <li>• Enter the motor rated current to parameter E2-01 as indicated on the motor nameplate.</li> </ul>
The maximum output frequency is set incorrectly		<ul style="list-style-type: none"> <li>• Check the rated frequency indicated on the motor nameplate.</li> <li>• Enter the rated frequency to E1-06 (Base Frequency).</li> </ul>
Multiple motors are running off the same drive		Set L1-01 to 0 to disable the motor protection function and then install a thermal relay to each motor.
The electrical thermal protection characteristics and motor overload characteristics do not match		<ul style="list-style-type: none"> <li>• Check the motor characteristics.</li> <li>• Correct the type of motor protection that has been selected (L1-01).</li> <li>• Install an external thermal relay.</li> </ul>
The electrical thermal relay is operating at the wrong level		<ul style="list-style-type: none"> <li>• Check the current rating listed on the motor nameplate.</li> <li>• Check the value set for the motor rated current (E2-01).</li> </ul>
Motor overheated by overexcitation operation		<ul style="list-style-type: none"> <li>• Overexcitation increases the motor loss and the motor temperature. Excessive duration of overexcitation may cause motor damage. Prevent excessive overexcitation operation or apply proper cooling to the motor.</li> <li>• Reduce the excitation deceleration gain (n3-13).</li> <li>• Set L3-04 (Stall Prevention during Deceleration) to a value other than 4.</li> </ul>
Parameters related to Speed Search are set incorrectly		<ul style="list-style-type: none"> <li>• Check values set to Speed Search related parameters.</li> <li>• Adjust the Speed Search current and Speed Search deceleration times (b3-02 and b3-03 respectively).</li> <li>• After Auto-Tuning, set b3-24 to 1 to enable Speed Estimation Speed Search.</li> </ul>
Output current fluctuation due to input phase loss		Check the power supply for phase loss.

Digital Operator Display		Fault Name
<i>oL2</i>	oL2	Drive Overload
		The thermal sensor of the drive triggered overload protection.
Cause		Possible Solution
Load is too heavy		Reduce the load.
Acceleration or deceleration time is too short		Increase the settings for the acceleration and deceleration times (C1-01 through C1-08).
The output voltage is too high		<ul style="list-style-type: none"> <li>• Adjust the preset V/f pattern (E1-04 through E1-10) by reducing E1-08 and E1-10.</li> <li>• Do not lower E1-08 and E1-10 excessively. This reduces load tolerance at low speeds.</li> </ul>
Drive capacity is too small		Replace the drive with a larger model.
Overload occurred when operating at low speeds		<ul style="list-style-type: none"> <li>• Reduce the load when operating at low speeds.</li> <li>• Replace the drive with a model that is one frame size larger.</li> <li>• Lower the carrier frequency (C6-02).</li> </ul>

## 2.4 Fault Detection

Excessive torque compensation	Reduce the torque compensation gain in parameter C4-01 until there is no speed loss but less current.
Parameters related to Speed Search are set incorrectly	<ul style="list-style-type: none"> <li>• Check the settings for all Speed Search related parameters.</li> <li>• Adjust the current used during Speed Search (b3-03) and the Speed Search deceleration time (b3-02).</li> <li>• After Auto-Tuning, set b3-24 to 1 to enable Speed Estimation Speed Search.</li> </ul>
Output current fluctuation due to input phase loss	Check the power supply for phase loss.

Digital Operator Display		Fault Name
oL3	oL3	Overtorque Detection 1 The current has exceeded the value set for torque detection (L6-02) for longer than the allowable time (L6-03).
<b>Cause</b>		<b>Possible Solution</b>
Parameter settings are not appropriate for the load		Check L6-02 and L6-03 settings.
Fault on the machine side (e.g., machine is locked up)		Check the status of the load. Remove the cause of the fault.

Digital Operator Display		Fault Name
oL4	oL4	Overtorque Detection 2 The current has exceeded the value set for Overtorque Detection 2 (L6-05) for longer than the allowable time (L6-06).
<b>Cause</b>		<b>Possible Solution</b>
Parameter settings are not appropriate for the load		Check the settings of parameters L6-05 and L6-06.

Digital Operator Display		Fault Name
oL5	oL5	Mechanical Weakening Detection 1 Overtorque occurred, matching the conditions specified in L6-08.
<b>Cause</b>		<b>Possible Solution</b>
Overtorque triggered mechanical weakening detection level set to L6-08		Identify the cause of mechanical weakening.

Digital Operator Display		Fault Name
oL7	oL7	High Slip Braking oL The output frequency stayed constant for longer than the time set to n3-04 during High Slip Braking.
<b>Cause</b>		<b>Possible Solution</b>
Excessive load inertia		<ul style="list-style-type: none"> <li>• Reduce deceleration times in parameters C1-02, C1-04, C1-06, and C1-08 for applications that do not use High Slip Braking.</li> <li>• Use a braking resistor to shorten deceleration time.</li> </ul>
Motor is driven by the load		
Something on the load side is restricting deceleration		
The overload time during High Slip Braking is too short		<ul style="list-style-type: none"> <li>• Increase parameter n3-04 (High-slip Braking Overload Time).</li> <li>• Install a thermal relay and increase the setting of n3-04 to maximum value.</li> </ul>

Digital Operator Display		Fault Name
oPr	oPr	External Digital Operator Connection Fault The external operator has been disconnected from the drive. <b>Note:</b> An oPr fault will occur when all of the following conditions are true: <ul style="list-style-type: none"> <li>• Output is interrupted when the operator is disconnected (o2-06 = 1).</li> <li>• The Run command is assigned to the operator (b1-02 = 0 and LOCAL has been selected).</li> </ul>
<b>Cause</b>		<b>Possible Solution</b>
External operator is not properly connected to the drive		<ul style="list-style-type: none"> <li>• Check the connection between the operator and the drive.</li> <li>• Replace the cable if damaged.</li> <li>• Turn off the drive input power and disconnect the operator. Reconnect the operator and reapply drive input power.</li> </ul>

Digital Operator Display		Fault Name
oS	oS	Overspeed (for Control Mode with PG) The motor speed feedback exceeded the F1-08 setting.

Cause	Possible Solution
Overshoot is occurring	<ul style="list-style-type: none"> <li>• Increase the settings for C5-01 (Speed Control Proportional Gain 1) and reduce C5-02 (Speed Control Integral Time 1).</li> <li>• If using Closed Loop Vector mode, enable Feed Forward and perform Inertia Auto-Tuning.</li> </ul>
Incorrect speed feedback scaling if terminal RP is used as speed feedback input in V/f control	<ul style="list-style-type: none"> <li>• Set H6-02 to the value of the speed feedback signal frequency when the motor runs at the maximum speed.</li> <li>• Adjust the input signal using parameters H6-03 through H6-05.</li> </ul>
Incorrect number of PG pulses has been set	Check and correct parameter F1-01.
Inappropriate parameter settings	Check the setting for the overspeed detection level and the overspeed detection time (F1-08 and F1-09).

Digital Operator Display		Fault Name
		Overvoltage
ou	ov	Voltage in the DC bus has exceeded the overvoltage detection level. <ul style="list-style-type: none"> <li>• For 400 V class drives: approximately 820 V (740 V when E1-01 is less than 400)</li> <li>• For 575 V class drives: approximately 1040 V</li> <li>• For 690 V class drives: approximately DC1200 V</li> </ul>
Cause	Possible Solution	
Deceleration time is too short and regenerative energy is flowing from the motor into the drive	<ul style="list-style-type: none"> <li>• Increase the deceleration time (C1-02, C1-04, C1-06, C1-08).</li> <li>• Install a dynamic braking resistor or a dynamic braking resistor unit.</li> <li>• Set L3-04 to 1 to enable stall prevention during deceleration. Stall Prevention is enabled as the default setting.</li> </ul>	
Fast acceleration time causes the motor to overshoot the speed reference	<ul style="list-style-type: none"> <li>• Check if sudden drive acceleration triggers an overvoltage alarm.</li> <li>• Increase the acceleration time.</li> <li>• Use longer S-curve acceleration and deceleration times.</li> <li>• Enable the Overvoltage Suppression function (L3-11 = 1).</li> <li>• Lengthen the S-curve at acceleration end.</li> </ul>	
Excessive braking load	The braking torque was too high, causing regenerative energy to charge the DC bus. Reduce the braking torque, use a dynamic braking option, or lengthen decel time.	
Surge voltage entering from the drive input power	Install a DC link choke. <b>Note:</b> Voltage surge can result from a thyristor convertor and phase advancing capacitor using the same input power supply.	
Ground fault in the output circuit causes the DC bus capacitor to overcharge	<ul style="list-style-type: none"> <li>• Check the motor wiring for ground faults.</li> <li>• Correct grounding shorts and reapply power.</li> </ul>	
Improper parameters related to Speed Search (including Speed Search after a momentary power loss and after a fault restart)	<ul style="list-style-type: none"> <li>• Check the settings for Speed Search-related parameters.</li> <li>• Enable Speed Search restart function (b3-19 greater than or equal to 1 to 10).</li> <li>• Adjust the current level during Speed Search and the deceleration time (b3-02 and b3-03 respectively).</li> <li>• Perform Stationary Auto-Tuning for line-to-line resistance and then set b3-14 to 1 to enable Speed Estimation Speed Search.</li> </ul>	
Drive input power voltage is too high	<ul style="list-style-type: none"> <li>• Check the voltage.</li> <li>• Lower drive input power voltage within the limits listed in the specifications.</li> </ul>	
The braking transistor or braking resistor are wired incorrectly	<ul style="list-style-type: none"> <li>• Check braking transistor and braking resistor wiring for errors.</li> <li>• Properly rewire the braking resistor device.</li> </ul>	
PG cable is disconnected	Reconnect the cable.	
PG cable wiring is wrong	Correct the wiring.	
Noise interference along the PG encoder wiring	Separate the wiring from the source of the noise. Often, this is the output lines from the drive.	
Drive fails to operate properly due to noise interference	<ul style="list-style-type: none"> <li>• Review the list of possible solutions provided for controlling noise.</li> <li>• Review the section on handling noise interference on page 228 and check the control circuit lines, main circuit lines, and ground wiring.</li> </ul>	
Load inertia is set incorrectly	<ul style="list-style-type: none"> <li>• Check the load inertia settings when using KEB, overvoltage suppression, or Stall Prevention during deceleration.</li> <li>• Adjust the load inertia ratio in L3-25 to better match the load.</li> </ul>	
Braking function is being used in OLV/PM	Connect a braking resistor.	

## 2.4 Fault Detection

Motor hunting occurs	<ul style="list-style-type: none"> <li>Adjust the parameters that control hunting.</li> <li>Set the gain for Hunting Prevention (n1-02).</li> <li>Adjust the AFR time constant (n2-02 and n2-03).</li> <li>Adjust the speed feedback detection suppression gain for PM motors (n8-45) and the time constant for pull-in current (n8-47).</li> </ul>
----------------------	---

Digital Operator Display		Fault Name
<i>PF</i>	PF	Input Phase Loss
		Drive input power has an open phase or has a large imbalance of voltage between phases. Detected when L8-05 is set 1 (enabled).
Cause		Possible Solution
There is phase loss in the drive input power		<ul style="list-style-type: none"> <li>Check for wiring errors in the main circuit drive input power.</li> <li>Correct the wiring.</li> </ul>
There is loose wiring in the drive input power terminals		<ul style="list-style-type: none"> <li>Ensure the terminals are tightened properly.</li> <li>Check for loose terminals.</li> </ul>
There is excessive fluctuation in the drive input power voltage		<ul style="list-style-type: none"> <li>Check the voltage from the drive input power.</li> <li>Review the possible solutions for stabilizing the drive input power.</li> </ul>
There is poor balance between voltage phases		Stabilize drive input power or disable phase loss detection.
The main circuit capacitors are worn		<ul style="list-style-type: none"> <li>Check the maintenance time for the capacitors (U4-05).</li> <li>Replace the capacitor if U4-05 is greater than 90%. For instructions on replacing the capacitor, contact Yaskawa or a Yaskawa representative.</li> </ul>
		Check for problems with the drive input power. If drive input power appears normal but the alarm continues to occur, replace either the control board or the entire drive. For instructions on replacing the control board, contact Yaskawa or a Yaskawa representative.

Digital Operator Display		Fault Name
<i>PG<sub>o</sub></i>	PGo	PG Disconnect (for any control modes using a PG option card)
		No PG pulses are received for longer than the time set to F1-14.
Cause		Possible Solution
PG cable is disconnected		Reconnect the cable.
PG cable wiring is wrong		Correct the wiring.
PG has no power		Check the power line to the PG encoder.
PG encoder brake is clamped shut		Ensure the motor brake releases properly.

Digital Operator Display		Fault Name
<i>PG<sub>oH</sub></i>	PGoH	PG Hardware Fault (detected when using a PG-X3 option card)
		PG cable is not connected properly.
Cause		Possible Solution
PG cable is disconnected		Reconnect the cable and check the setting of F1-20.

Digital Operator Display		Fault Name
<i>PUF</i>	PUF	Fuse is Open
		One of the Module DC Bus Fuses is/are open.
Cause		Possible Solution
Main transistor failure, or one or more module DC Bus Fuses is/are open		<ul style="list-style-type: none"> <li>Use monitor U2-28 to identify the defective module(s)</li> <li>Replace or repair the defective module..</li> </ul>

Digital Operator Display		Fault Name
<i>rF</i>	rF	Braking Resistor Fault
		The resistance of the braking resistor is too low.
Cause		Possible Solution
The proper braking resistor option has not been installed		Select a braking resistor option that it fits the drive braking transistor specification.
A regenerative converter, regenerative unit, or braking unit is being used		Set L8-55 to 0 to disable the braking transistor protection selection.

Digital Operator Display		Fault Name
$rH$	rH	Braking Resistor Overheat
		Braking resistor protection was triggered. Fault detection is enabled when L8-01 = 1 (disabled as a default).
Cause		Possible Solution
Deceleration time is too short and excessive regenerative energy is flowing back into the drive		<ul style="list-style-type: none"> <li>Check the load, deceleration time, and speed.</li> <li>Reduce the load inertia.</li> <li>Increase the deceleration times (C1-02, C1-04, C1-06, C1-08, C1-09).</li> <li>Replace the dynamic braking option with a larger device that can handle the power that is discharged.</li> </ul>
Excessive braking inertia		Recalculate braking load and braking power. Reduce the braking load by adjusting braking resistor settings.
The braking operation duty cycle is too high		Check the braking operation duty cycle. Braking resistor protection for ERF-type braking resistors (L8-01 = 1) allows a braking duty cycle of maximum 3%.
The proper braking resistor has not been installed		<ul style="list-style-type: none"> <li>Check the specifications and conditions for the braking resistor device.</li> <li>Select the optimal braking resistor.</li> </ul>
<b>Note:</b> The magnitude of the braking load trips the braking resistor overheat alarm, NOT the surface temperature. Using the braking resistor more frequently than its rating permits will trip the alarm even when the braking resistor surface is not very hot.		

Digital Operator Display		Fault Name
$rr$	rr	Dynamic Braking Transistor
		The built-in dynamic braking transistor failed.
Cause		Possible Solution
The braking transistor is damaged		<ul style="list-style-type: none"> <li>Cycle power to the drive and check for reoccurrence of the fault.</li> </ul>
The control circuit is damaged		<ul style="list-style-type: none"> <li>Replace either the control board or the entire drive. For instructions on replacing the control board, contact Yaskawa or a Yaskawa representative.</li> </ul>

Digital Operator Display		Fault Name
$SC$ </>	SC	IGBT Short Circuit or Ground Fault
Cause		Possible Solution
IGBT fault		<ul style="list-style-type: none"> <li>Check motor wiring.</li> </ul>
IGBT short circuit detection circuit fault		<ul style="list-style-type: none"> <li>Turn off the power supply, then turn it on. If the problem continues, contact your Yaskawa representative or the nearest Yaskawa sales office.</li> </ul>

<1> Available in drive software versions 1015 and later for standard A1000 and 1012 and later for A1000 HHP models.

Digital Operator Display		Fault Name
$SEr$	SEr	Too Many Speed Search Restarts
		The number of Speed Search restarts exceeded the value set to b3-19.
Cause		Possible Solution
Parameters related to Speed Search are set to the wrong values		<ul style="list-style-type: none"> <li>Reduce the detection compensation gain during Speed Search (b3-10).</li> <li>Increase the current level when attempting Speed Search (b3-17).</li> <li>Increase the detection time during Speed Search (b3-18).</li> <li>Repeat Auto-Tuning.</li> </ul>
The motor is coasting in the opposite direction of the Run command		Set b3-14 to 1 to enable Bi-Directional Speed Search.

Digital Operator Display		Fault Name
$SvE$	SvE	Zero Servo Fault
		Position deviation during zero servo.
Cause		Possible Solution
Torque limit is set too low		Set the torque limit to an appropriate value using parameters L7-01 to L7-04.
Excessive load torque		Reduce the amount of load torque.
Noise interference along PG encoder wiring		Check the PG signal for noise interference.

Digital Operator Display		Fault Name
$THo$	THo	Thermistor Disconnect
		The thermistor that detects motor temperature has become disconnected.

## 2.4 Fault Detection

Cause	Possible Solution
The motor thermistor is not connected properly.	Check the thermistor wiring.

Digital Operator Display		Fault Name
UL3	UL3	Undertorque Detection 1
		The current has fallen below the minimum value set for torque detection (L6-02) for longer than the allowable time (L6-03).
Cause		Possible Solution
Parameter settings are not appropriate for the load		Check the settings of parameters L6-02 and L6-03.
There is a fault on the machine side		Check the load for any problems.

Digital Operator Display		Fault Name
UL4	UL4	Undertorque Detection 2
		The current has fallen below the minimum value set for torque detection (L6-05) for longer than the allowable time (L6-06).
Cause		Possible Solution
Parameter settings are not appropriate for the load		Check L6-05 and L6-06 settings
There is a fault on the machine side		Check the load for any problems.

Digital Operator Display		Fault Name
UL5	UL5	Mechanical Weakening Detection 2
		The operation conditions matched the conditions set to L6-08.
Cause		Possible Solution
Undertorque was detected and matched the conditions for mechanical loss detection set to L6-08		Check the load side for any problems.

Digital Operator Display		Fault Name
UnbC	UnbC	Current Unbalance
		Current flow has become unbalanced.
Cause		Possible Solution
The internal current sensor has detected a current unbalance situation.		<ul style="list-style-type: none"> <li>• Check wiring</li> <li>• Check for damaged transistors.</li> <li>• Check for short circuits or grounding problems on the connected motor.</li> </ul>

Digital Operator Display		Fault Name
Uv1	Uv1	DC Bus Undervoltage
		Voltage in the DC bus fell below the undervoltage detection level (L2-05). <ul style="list-style-type: none"> <li>• For 400 V class drives: approximately 380 V (350 V when E1-01 is less than 400)</li> <li>• For 575 V class drives: approximately 475 V</li> <li>• For 690 V class drives: approximately 570 V</li> </ul> The fault is output only if L2-01 is set to 0 or 1 and the DC bus voltage has fallen below the level set to L2-05 for longer than the time set to L2-02.
Cause		Possible Solution
Input power phase loss		<ul style="list-style-type: none"> <li>• The main circuit drive input power is wired incorrectly.</li> <li>• Correct the wiring.</li> </ul>
One of the drive input power wiring terminals is loose		<ul style="list-style-type: none"> <li>• Ensure there are no loose terminals.</li> <li>• Check for loose terminals.</li> </ul>
There is a problem with the voltage from the drive input power		<ul style="list-style-type: none"> <li>• Check the voltage.</li> <li>• Correct the voltage to be within the range listed in drive input power specifications.</li> <li>• If there is no problem with the power supply to the main circuit, check for problems with the main circuit magnetic contactor.</li> </ul>

The power has been interrupted	Correct the drive input power.
The main circuit capacitors are worn	<ul style="list-style-type: none"> <li>• Check the maintenance time for the capacitors (U4-05).</li> <li>• Replace either the control board or the entire drive if U4-05 exceeds 90%. For instructions on replacing the control board, contact Yaskawa or a Yaskawa representative.</li> </ul>
The relay or contactor on the soft-charge bypass circuit is damaged	<ul style="list-style-type: none"> <li>• Cycle power to the drive and see if the fault reoccurs.</li> <li>• If the problem continues, replace either the control board or the entire drive. For instructions on replacing the control board, contact Yaskawa or a Yaskawa representative.</li> <li>• Check monitor U4-06 for the performance life of the soft-charge bypass.</li> <li>• Replace either the control board or the entire drive if U4-06 exceeds 90%. For instructions on replacing the control board, contact Yaskawa or a Yaskawa representative.</li> </ul>

Digital Operator Display		Fault Name
Uv2	Uv2	Control Power Supply Voltage Fault
Cause		Possible Solution
In drive models CIMR-A□2A0004 to 2A0056 or 4A0002 to 4A0031, L2-02 was changed from its default value without installing a Momentary Power Loss Ride-Thru unit		Correct the setting to L2-02 or install an optional Momentary Power Loss Ride-Thru unit.
Control power supply wiring is damaged		<ul style="list-style-type: none"> <li>• Cycle power to the drive. Check if the fault reoccurs.</li> <li>• If the problem continues, replace the control board, the entire drive, or the control power supply. For instructions on replacing the control board, contact Yaskawa or a Yaskawa representative.</li> </ul>
Internal circuitry is damaged		<ul style="list-style-type: none"> <li>• Cycle power to the drive. Check if the fault reoccurs.</li> <li>• If the problem continues, replace either the control board or the entire drive. For instructions on replacing the control board, contact Yaskawa or a Yaskawa representative.</li> </ul>

Digital Operator Display		Fault Name
Uv3	Uv3	Undervoltage 3 (Soft-Charge Bypass Circuit Fault)
Cause		Possible Solution
The relay or contactor on the soft-charge bypass circuit is damaged		<ul style="list-style-type: none"> <li>• Cycle power to the drive and see if the fault reoccurs.</li> <li>• If the problem continues, replace either the control board or the entire drive. For instructions on replacing the control board, contact Yaskawa or a Yaskawa representative.</li> <li>• Check monitor U4-06 for the performance life of the soft-charge bypass.</li> <li>• Replace either the control board or the entire drive if U4-06 exceeds 90%. For instructions on replacing the control board, contact Yaskawa or a Yaskawa representative.</li> </ul>

Digital Operator Display		Fault Name
Uv4	Uv4	Gate Drive Board Undervoltage
Cause		Possible Solution
Not enough power is being supplied to the gate drive board.		<ul style="list-style-type: none"> <li>• Cycle power to the drive and see if the fault reoccurs. <i>Refer to Diagnosing and Resetting Faults on page 221</i> for details.</li> <li>• If the problem continues, replace either the gate drive board or the entire drive. For instructions on replacing the gate drive board, contact Yaskawa or a Yaskawa representative.</li> </ul>

Digital Operator Display		Fault Name
Uv5	Uv5	MC/FAN power malfunction
Cause		Possible Solution
Internal drive module MC / FAN power supply is low.		<ul style="list-style-type: none"> <li>• Power the drive ON/OFF to verify operation.</li> <li>• Refer to the manual section on how to restart the drive after an error.</li> <li>• If the error occurs again replace the defective module or defective circuit board..</li> </ul>

## 2.4 Fault Detection

Digital Operator Display		Fault Name
uoF	voF	Output Voltage Detection Fault
		Problem detected with the voltage on the output side of the drive.
Cause		Possible Solution
Hardware is damaged. Internal drive module MC / FAN overheat protection circuit board is due to abnormal ambient operating power.		<ul style="list-style-type: none"> <li>• Lower ambient temperature.</li> <li>• Replace the control board or the entire drive. For instructions on replacing the control board, contact Yaskawa or a Yaskawa representative..</li> </ul>



## 2.5 Alarm Detection

### ◆ Alarm Codes, Causes, and Possible Solutions

Alarms are drive protection functions that do not necessarily cause the drive to stop. Once the cause of an alarm is removed, the drive will return to the same status it was before the alarm occurred.

When an alarm has been triggered, the ALM light on the digital operator display blinks and the alarm code display flashes. If a multi-function output is set for an alarm (H2-□□ = 10), that output terminal will be triggered.

**Note:** If a multi-function output is set to close when an alarm occurs (H2-□□ = 10), it will also close when maintenance periods are reached, triggering alarms LT-1 through LT-4 (triggered only if H2-□□ = 2F).

**Table 2.11 Alarm Codes, Causes, and Possible Solutions**

Digital Operator Display		Minor Fault Name
<i>AEr</i>	AEr	Communication Option Station Number Setting Error (CC-Link, CANopen, MECHATROLINK-II)
<b>Cause</b>		<b>Possible Solutions</b>
Station number is set outside the possible setting range.		<ul style="list-style-type: none"> <li>Set parameter F6-10 to the proper value when using a CC-Link option.</li> <li>Set parameter F6-35 to the proper value when using a CANopen option.</li> </ul>
Digital Operator Display		Minor Fault Name
<i>bb</i>	bb	Baseblock
<b>Cause</b>		<b>Possible Solutions</b>
External baseblock signal was entered via one of the multi-function input terminals (S1 to S8).		Check external sequence and baseblock signal input timing.
Digital Operator Display		Minor Fault Name
<i>boL</i>	boL	Braking Transistor Overload Fault
<b>Cause</b>		<b>Possible Solutions</b>
The proper braking resistor has not been installed.		Select the proper braking resistor.
Digital Operator Display		Minor Fault Name
<i>bUS</i>	bUS	Option Communication Error
<b>Cause</b>		<b>Possible Solutions</b>
Connection is broken or master controller stopped communicating.		<ul style="list-style-type: none"> <li>Check for faulty wiring.</li> <li>Correct the wiring.</li> <li>Check for disconnected cables and short circuits. Repair as needed.</li> </ul>
Option is damaged.		If there are no problems with the wiring and the fault continues to occur, replace the option.
The option is not properly connected to the drive.		<ul style="list-style-type: none"> <li>The connector pins on the option are not properly lined up with the connector pins on the drive.</li> <li>Reinstall the option.</li> </ul>
A data error occurred due to noise.		<ul style="list-style-type: none"> <li>Check options available to minimize the effects of noise.</li> <li>Take steps to counteract noise in the control circuit wiring, main circuit lines and ground wiring.</li> <li>Try to reduce noise on the controller side.</li> <li>Use surge absorbers on magnetic contactors or other equipment causing the disturbance.</li> <li>Use recommended cables or some other type of shielded line. Ground the shield to the controller side or on the input power side.</li> <li>Separate the wiring for communication devices from the drive input power lines. Install an EMC noise filter to the drive input power.</li> </ul>

## 2.5 Alarm Detection

Digital Operator Display		Minor Fault Name
CALL	CALL	Serial Communication Transmission Error
		Communication has not yet been established.
<b>Cause</b>		<b>Possible Solutions</b>
Communications wiring is faulty, there is a short circuit, or something is not connected properly.		<ul style="list-style-type: none"> <li>• Check for wiring errors.</li> <li>• Correct the wiring.</li> <li>• Check for disconnected cables and short circuits. Repair as needed.</li> </ul>
Programming error on the master side.		Check communications at start-up and correct programming errors.
Communications circuitry is damaged.		<ul style="list-style-type: none"> <li>• Perform a self-diagnostics check.</li> <li>• If the problem continues, replace either the control board or the entire drive. For instructions on replacing the control board, contact Yaskawa or your nearest sales representative.</li> </ul>
Termination resistor setting is incorrect.		Install a termination resistor at both ends of a communication line. Set the internal termination resistor switch correctly on slave drives. Place DIP switch S2 to the ON position.

Digital Operator Display		Minor Fault Name
EE	CE	MEMOBUS/Modbus Communication Error
		Control data was not received correctly for two seconds.
<b>Cause</b>		<b>Possible Solutions</b>
A data error occurred due to noise.		<ul style="list-style-type: none"> <li>• Check options available to minimize the effects of noise.</li> <li>• Take steps to counteract noise in the control circuit wiring, main circuit lines, and ground wiring.</li> <li>• Reduce noise on the controller side.</li> <li>• Use surge absorbers for the magnetic contactors or other components that may be causing the disturbance.</li> <li>• Use only recommended shielded line. Ground the shield on the controller side or on the drive input power side.</li> <li>• Separate all wiring for communication devices from drive input power lines. Install an EMC noise filter to the drive input power supply.</li> </ul>
Communication protocol is incompatible.		<ul style="list-style-type: none"> <li>• Check the H5 parameter settings and the protocol setting in the controller.</li> <li>• Ensure settings are compatible.</li> </ul>
The CE detection time (H5-09) is set shorter than the time required for a communication cycle to take place.		<ul style="list-style-type: none"> <li>• Check the PLC.</li> <li>• Change the software settings in the PLC.</li> <li>• Set a longer CE detection time using parameter H5-09.</li> </ul>
Incompatible PLC software settings or there is a hardware problem.		<ul style="list-style-type: none"> <li>• Check the PLC.</li> <li>• Remove the cause of the error on the controller side.</li> </ul>
Communications cable is disconnected or damaged.		<ul style="list-style-type: none"> <li>• Check the connector to make sure the cable has a signal.</li> <li>• Replace the communications cable.</li> </ul>

Digital Operator Display		Minor Fault Name
CrST	CrST	Cannot Reset
		<b>Possible Solutions</b>
Fault reset was being executed when a Run command was entered.		<ul style="list-style-type: none"> <li>• Ensure that a Run command cannot be entered from the external terminals or option during fault reset.</li> <li>• Turn off the Run command.</li> </ul>

Digital Operator Display		Minor Fault Name
dEv	dEv	Speed Deviation (when using a PG option card)
		The deviation between the speed reference and speed feedback is greater than the setting in F1-10 for longer than the time in F1-11.
<b>Cause</b>		<b>Possible Solutions</b>
Load is too heavy		Reduce the load.
Acceleration and deceleration times are set too short.		Increase the acceleration and deceleration times (C1-01 through C1-08).
The load is locked up.		Check the machine.
Parameter settings are inappropriate.		Check the settings of parameters F1-10 and F1-11.
Incorrect speed feedback scaling when using terminal RP as speed feedback input in V/f Control.		<ul style="list-style-type: none"> <li>• Set H6-02 to value of the speed feedback signal frequency when the motor runs at the maximum speed.</li> <li>• Adjust the speed feedback signal using parameters H6-03 through H6-05.</li> <li>• Make sure the speed feedback signal frequency does not exceed the maximum input frequency of terminal RP.</li> </ul>

The motor brake engaged.	Ensure the brake releases properly.
--------------------------	-------------------------------------

Digital Operator Display		Minor Fault Name
<i>dFRn</i>	dFAn	Abnormal Diode Module Fan Displays when diode converter module(s) has a fan alarm
<b>Cause</b>		<b>Possible Solution</b>
Diode module cooling fan has malfunctioned		<ul style="list-style-type: none"> <li>• Cycle power to the drive. • Check for fan operation..</li> <li>• Check for fan operation.</li> <li>• Verify the cumulative operation time of the fan with monitor U4-03, and verify the cumulative operation time of the fan maintenance timer with U4-04.</li> <li>• If the cooling fan has exceeded its expected performance life or is damaged in any other way, replace the cooling fan.</li> </ul>

Digital Operator Display		Minor Fault Name
<i>dnE</i>	dnE	Drive Disabled
<b>Cause</b>		<b>Possible Solutions</b>
“Drive Enable” is set to a multi-function contact input (H1-□□ = 6A) and that signal was switched off.		Check the operation sequence.

Digital Operator Display		Minor Fault Name
<i>EF</i>	EF	Forward/Reverse Run Command Input Error Both forward run and reverse run closed simultaneously for longer than 0.5 s.
<b>Cause</b>		<b>Possible Solutions</b>
Sequence error		Check the forward and reverse command sequence and correct the problem. <b>Note:</b> When minor fault EF detected, motor ramps to stop.

Digital Operator Display		Minor Fault Name
<i>EFAn</i>	EFAAn	Abnormal Panel Fan Displays when the Panel Fan Control detects a fan Alarm
<b>Cause</b>		<b>Possible Solution</b>
Panel fan or panel fan control has malfunctioned		<ul style="list-style-type: none"> <li>• Cycle power to the drive.</li> <li>• Check for fan operation.</li> <li>• Verify the cumulative operation time of the fan with monitor U4-03, and verify the cumulative operation time of the fan maintenance timer with U4-04.</li> <li>• If the cooling fan has exceeded its expected performance life or is damaged in any other way, replace the cooling fan.</li> </ul>

Digital Operator Display		Minor Fault Name
<i>EF0</i>	EF0	Option Card External Fault An external fault condition is present.
<b>Cause</b>		<b>Possible Solutions</b>
An external fault was received from the PLC with F6-03 set to 3, which allows the drive to continue running after an external fault occurs.		<ul style="list-style-type: none"> <li>• Remove the cause of the external fault.</li> <li>• Remove the external fault input from the PLC.</li> </ul>
There is a problem with the PLC program.		Check the PLC program and correct problems.

Digital Operator Display		Minor Fault Name
<i>EF1</i>	EF1	External Fault (Input Terminal S1) External fault at multi-function input terminal S1.
<i>EF2</i>	EF2	External fault (input terminal S2) External fault at multi-function input terminal S2.
<i>EF3</i>	EF3	External fault (input terminal S3) External fault at multi-function input terminal S3.
<i>EF4</i>	EF4	External fault (input terminal S4) External fault at multi-function input terminal S4.

## 2.5 Alarm Detection

<i>EF5</i>	EF5	External fault (input terminal S5)
		External fault at multi-function input terminal S5.
<i>EF6</i>	EF6	External fault (input terminal S6)
		External fault at multi-function input terminal S6.
<i>EF7</i>	EF7	External fault (input terminal S7)
		External fault at multi-function input terminal S7.
<i>EF8</i>	EF8	External fault (input terminal S8)
		External fault at multi-function input terminal S8.
<b>Cause</b>		<b>Possible Solutions</b>
An external device has tripped an alarm function.		Remove the cause of the external fault and reset the multi-function input value.
Wiring is incorrect.		<ul style="list-style-type: none"> <li>Ensure the signal lines have been connected properly to the terminals assigned for external fault detection (H1-□□ = 20 to 2F).</li> <li>Reconnect the signal line.</li> </ul>
Multi-function contact inputs are set incorrectly.		<ul style="list-style-type: none"> <li>Check if the unused terminals have been set for H1-□□ = 20 to 2F (External Fault).</li> <li>Change the terminal settings.</li> </ul>

Digital Operator Display		Minor Fault Name
<i>FbH</i>	FbH	Excessive PID Feedback
		The PID feedback input is higher than the level set to b5-36 for longer than the time set to b5-37, and b5-12 is set to 1 or 4.
<b>Cause</b>		<b>Possible Solutions</b>
Parameter settings for b5-36 and b5-37 are incorrect.		Check parameters b5-36 and b5-37.
PID feedback wiring is faulty.		Correct the wiring.
Feedback sensor has malfunctioned.		Check the sensor and replace it if damaged.
Feedback input circuit is damaged.		Replace either the control board or the entire drive. For instructions on replacing the control board, contact Yaskawa or your nearest sales representative.

Digital Operator Display		Minor Fault Name
<i>FbL</i>	FbL	PID Feedback Loss
		The PID feedback input is lower than the level set to b5-13 for longer than the time set to b5-14, and b5-12 is set to 1 or 4.
<b>Cause</b>		<b>Possible Solutions</b>
Parameter settings for b5-13 and b5-14 are incorrect.		Check parameters b5-13 and b5-14.
PID feedback wiring is faulty.		Correct the wiring.
Feedback sensor has malfunctioned.		Check the sensor and replace it if damaged.
Feedback input circuit is damaged.		Replace either the control board or the entire drive. For instructions on replacing the control board, contact Yaskawa or your nearest sales representative.

Digital Operator Display		Minor Fault Name
<i>Hbb</i>	Hbb	Safe Disable Signal Input </>
		Both Safe Disable Input channels are open.
<b>Cause</b>		<b>Possible Solutions</b>
Both Safe Disable Inputs H1 and H2 are open.		<ul style="list-style-type: none"> <li>Check signal status at the input terminals H1 and H2.</li> <li>Check the Sink/Source Selection for the digital inputs.</li> <li>If the Safe Disable function is not utilized, determine if terminals H1-HC, and H2-HC are linked.</li> </ul>
Internally, both Safe Disable channels are broken.		Replace either the control board or the entire drive. For instructions on replacing the control board, contact Yaskawa or your nearest sales representative.

<1> Terminals H1, H2, DM+, and DM- on 600 V class models are designed to the functionality, but are not certified to EN61800-5-1, ISO13849 Cat. 3, IEC/EN61508 SIL2, Insulation coordination: class 1.

Digital Operator Display		Minor Fault Name
<i>HbbF</i>	HbbF	Safe Disable Signal Input </>
		One Safe Disable channel is open while the other channel is closed.

Cause	Possible Solutions
The signals to the Safe Disable inputs are wrong or the wiring is incorrect.	Check signal status at the input terminals H1 and H2. If the Safe Disable function is not utilized, terminals H1-HC, and H2-HC must be linked.
One of the Safe Disable channels is faulty.	Replace either the control board or the entire drive. For instructions on replacing the control board, contact Yaskawa or your nearest sales representative.

<1> Terminals H1, H2, DM+, and DM- on 600 V class models are designed to the functionality, but are not certified to EN61800-5-1, ISO13849 Cat. 3, IEC/EN61508 SIL2, Insulation coordination: class 1.

Digital Operator Display		Minor Fault Name
HCR	HCA	Current Alarm
		Drive current exceeded overcurrent warning level (150% of the rated current).
Cause		Possible Solutions
Load is too heavy.		Reduce the load for applications with repetitive operations (i.e., stops and starts.), or replace the drive.
Acceleration and deceleration times are too short.		<ul style="list-style-type: none"> <li>Calculate the torque required during acceleration and for the inertia moment.</li> <li>If the torque level is not right for the load, take the following steps:</li> <li>Increase the acceleration and deceleration times (C1-01 through C1-08).</li> <li>Increase the capacity of the drive.</li> </ul>
A special-purpose motor is being used, or the drive is attempting to run a motor greater than the maximum allowable capacity.		<ul style="list-style-type: none"> <li>Check the motor capacity.</li> <li>Use a motor appropriate for the drive. Ensure the motor is within the allowable capacity range.</li> </ul>
The current level increased due to Speed Search after a momentary power loss or while attempting to perform a fault restart.		The alarm will only appear briefly. There is no need to take action to prevent the alarm from occurring in such instances.

Digital Operator Display		Minor Fault Name
LF-1	LT-1	Cooling Fan Maintenance Time
		The cooling fan has reached its expected maintenance period and may need to be replaced. <b>Note:</b> An alarm output (H2-□□ = 10) will only be triggered if both (H2-□□ = 2F and H2-□□ = 10) are set.
Cause		Possible Solutions
The cooling fan has reached 90% of its expected performance life.		Replace the cooling fan and set o4-03 to 0 to reset the Maintenance Monitor.

Digital Operator Display		Minor Fault Name
LF-2	LT-2	Capacitor Maintenance Time
		The main circuit and control circuit capacitors are nearing the end of their expected performance life. <b>Note:</b> An alarm output (H2-□□ = 10) will only be triggered if H2-□□ = 2F.
Cause		Possible Solutions
The main circuit and control circuit capacitors have reached 90% of their expected performance lives.		Replace either the control board or the entire drive. For instructions on replacing the control board, contact Yaskawa or your nearest sales representative.

Digital Operator Display		Minor Fault Name
LF-3	LT-3	Soft Charge Bypass Relay Maintenance Time
		The DC bus soft charge relay is nearing the end of its expected performance life. <b>Note:</b> An alarm output (H2-□□ = 10) will only be triggered if H2-□□ = 2F.
Cause		Possible Solutions
The DC bus soft charge relay has reached 90% of expected performance life.		Replace either the control board or the entire drive. For instructions on replacing the control board, contact Yaskawa or your nearest sales representative.

Digital Operator Display		Minor Fault Name
LF-4	LT-4	IGBT Maintenance Time (50%)
		IGBTs have reached 50% of their expected performance life. <b>Note:</b> An alarm output (H2-□□ = 10) will only be triggered if H2-□□ = 2F.
Cause		Possible Solutions

## 2.5 Alarm Detection

IGBTs have reached 50% of their expected performance life.		Check the load, carrier frequency, and output frequency.
Digital Operator Display		Minor Fault Name
oH	oH	Heatsink Overheat The temperature of the heatsink exceeded the overheat pre-alarm level set to L8-02 (90-100 °C). Default value for L8-02 is determined by drive capacity (o2-04).
Cause		Possible Solutions
Surrounding temperature is too high		<ul style="list-style-type: none"> <li>• Check the surrounding temperature.</li> <li>• Improve the air circulation within the enclosure panel.</li> <li>• Install a fan or air conditioner to cool surrounding area.</li> <li>• Remove anything near drive that may cause extra heat.</li> </ul>
Internal cooling fan has stopped.		<ul style="list-style-type: none"> <li>• Replace the cooling fan.</li> <li>• After replacing the drive, set parameter o4-03 to 0 to reset the cooling fan operation time.</li> </ul>
Airflow around the drive is restricted.		<ul style="list-style-type: none"> <li>• Provide proper installation space around the drive.</li> <li>• Allow for the proper space and ensure that there is sufficient circulation around the control panel.</li> <li>• Check for dust or other foreign materials clogging the cooling fan.</li> <li>• Clear debris caught in the fan that restricts air circulation.</li> </ul>
Digital Operator Display		Minor Fault Name
oH2	oH2	Drive Overheat Warning “Drive Overheat Warning” was input to a multi-function input terminal, S1 through S8 (H1-□□= B).
Cause		Possible Solutions
An external device triggered an overheat warning in the drive.		Search for the device that tripped the overheat warning. Remove the cause of the problem.
Digital Operator Display		Minor Fault Name
oH3	oH3	Motor Overheat The motor overheat signal entered to a multi-function analog input terminal exceeded the alarm level (H3-02, H3-06 or H3-10 = E).
Cause		Possible Solutions
Motor thermostat wiring is faulty (PTC input).		Repair the PTC input wiring.
There is a fault on the machine side (e.g., the machine is locked up).		<ul style="list-style-type: none"> <li>• Check the status of the machine.</li> <li>• Remove the cause of the fault.</li> </ul>
Motor has overheated.		<ul style="list-style-type: none"> <li>• Check the load size, accel/decel times, and cycle times.</li> <li>• Decrease the load.</li> <li>• Increase accel and decel times (C1-01 to C1-08).</li> <li>• Adjust the preset V/f pattern (E1-04 through E1-10). This involves reducing E1-08 and E1-10. <b>Note:</b> Refrain from lowering E1-08 and E1-10 excessively to prevent a reduction in load tolerance at low speeds.</li> <li>• Check the motor-rated current.</li> <li>• Enter motor-rated current on motor nameplate (E2-01).</li> <li>• Ensure the motor cooling system is operating normally.</li> <li>• Repair or replace the motor cooling system.</li> </ul>
Digital Operator Display		Minor Fault Name
oH5	oH5	Motor Overheat (NTC Input) The motor temperature exceeded the level set to L1-16 (or L1-18 for motor 2)
Cause		Possible Solutions
Motor has overheated.		<ul style="list-style-type: none"> <li>• Reduce the load.</li> <li>• Check the ambient temperature.</li> </ul>

Digital Operator Display		Minor Fault Name
oL3	oL3	Overtorque 1
		Drive output current (or torque in OLV, CLV, AOLV/PM, and CLV/PM) was greater than L6-02 for longer than the time set to L6-03.
<b>Cause</b>		<b>Possible Solutions</b>
Inappropriate parameter settings.		Check parameters L6-02 and L6-03.
There is a fault on the machine side (e.g., the machine is locked up).		<ul style="list-style-type: none"> <li>• Check the status of the machine.</li> <li>• Remove the cause of the fault.</li> </ul>

Digital Operator Display		Minor Fault Name
oL4	oL4	Overtorque 2
		Drive output current (or torque in OLV, CLV, AOLV/PM, CLV/PM) was greater than L6-05 for longer than the time set to L6-06.
<b>Cause</b>		<b>Possible Solutions</b>
Parameter settings are not appropriate.		Check parameters L6-05 and L6-06.
There is a fault on the machine side (e.g., the machine is locked up).		<ul style="list-style-type: none"> <li>• Check the status of the machine being used.</li> <li>• Remove the cause of the fault.</li> </ul>

Digital Operator Display		Minor Fault Name
oL5	oL5	Mechanical Weakening Detection 1
		Overtorque occurred, matching the conditions specified in L6-08.
<b>Cause</b>		<b>Possible Solutions</b>
Overtorque occurred, triggering the mechanical weakening level set to L6-08.		Check for the cause of mechanical weakening.

Digital Operator Display		Minor Fault Name
oS	oS	Overspeed (for Control Mode with PG)
		The motor speed feedback exceeded the F1-08 setting.
<b>Cause</b>		<b>Possible Solutions</b>
Overshoot is occurring.		<ul style="list-style-type: none"> <li>• Increase the settings for C5-01 (Speed Control Proportional Gain 1) and reduce C5-02 (Speed Control Integral Time 1).</li> <li>• If using a Closed Loop Vector mode enable Feed Forward Control and perform Inertia Auto-Tuning.</li> </ul>
Incorrect speed feedback scaling if terminal RP is used as speed feedback input in V/f control		<ul style="list-style-type: none"> <li>• Set H6-02 to value of the speed feedback signal frequency when the motor runs at the maximum speed.</li> <li>• Adjust the input signal using parameters H6-03 through H6-05.</li> </ul>
Incorrect PG pulse number has been set		Check and correct parameter F1-01.
Inappropriate parameter settings.		Check the setting for the overspeed detection level and the overspeed detection time (F1-08 and F1-09).

Digital Operator Display		Minor Fault Name
oV	oV	DC Bus Overvoltage
		The DC bus voltage exceeded the trip point. <ul style="list-style-type: none"> <li>• For 400 V class drives: approximately 820 V (740 V when E1-01 is less than 400)</li> <li>• For 575 V class drives: approximately 1040 V</li> <li>• For 690 V class drives: approximately xxx V</li> </ul>
<b>Cause</b>		<b>Possible Solutions</b>
Surge voltage present in the drive input power.		<ul style="list-style-type: none"> <li>• Install a DC link choke or an AC reactor.</li> <li>• Voltage surge can result from a thyristor convertor and a phase advancing capacitor operating on the same drive input power system.</li> </ul>
The motor is short-circuited.		<ul style="list-style-type: none"> <li>• Check the motor power cable, relay terminals and motor terminal box for short circuits.</li> <li>• Correct grounding shorts and turn the power back on.</li> </ul>
Ground current has overcharged the main circuit capacitors via the drive input power.		
Noise interference causes the drive to operate incorrectly.		<ul style="list-style-type: none"> <li>• Review possible solutions for handling noise interference.</li> <li>• Review section on handling noise interference and check control circuit lines, main circuit lines and ground wiring.</li> <li>• If the magnetic contactor is identified as a source of noise, install a surge protector to the MC coil.</li> </ul>
		Set number of fault restarts (L5-01) to a value other than 0.
PG cable is disconnected.		Reconnect the cable.

## 2.5 Alarm Detection

PG cable wiring is wrong.	Correct the wiring.
Noise interference along PG encoder wiring.	Separate PG wiring from the source of the noise (often output wiring from the drive).

Digital Operator Display		Minor Fault Name
<i>PASS</i>	PASS	MEMOBUS/Modbus Comm. Test Mode Complete
<b>Cause</b>		<b>Possible Solutions</b>
MEMOBUS/Modbus test has finished normally.		This verifies that the test was successful.

Digital Operator Display		Minor Fault Name
<i>PGo</i>	PGo	PG Disconnect (for Control Mode with PG) Detected when no PG pulses are received for a time longer than setting in F1-14.
<b>Cause</b>		<b>Possible Solutions</b>
PG cable is disconnected.		Reconnect the cable.
PG cable wiring is wrong.		Correct the wiring.
PG encoder does not have enough power.		Make sure the correct power supply is properly connected to the PG encoder.
Brake is holding the PG.		Ensure the brake releases properly

Digital Operator Display		Minor Fault Name
<i>PGoH</i>	PGoH	PG Hardware Fault (detected when using a PG-X3 option card) PG cable has become disconnected.
<b>Cause</b>		<b>Possible Solutions</b>
PG cable is disconnected.		Reconnect the cable and check the setting of F1-20.

Digital Operator Display		Minor Fault Name
<i>rUn</i>	rUn	Motor Switch during Run A command to switch motors was entered during run.
<b>Cause</b>		<b>Possible Solutions</b>
A motor switch command was entered during run.		Change the operation pattern so that the motor switch command is entered while the drive is stopped.

Digital Operator Display		Minor Fault Name
<i>SE</i>	SE	MEMOBUS/Modbus Communication Test Mode Error <b>Note:</b> This alarm will not trigger a multi-function output terminal that is set for alarm output (H2-□□ = 10).
<b>Cause</b>		<b>Possible Solutions</b>
A digital input set to 67H (MEMOBUS/Modbus test) was closed while the drive was running.		Stop the drive and run the test again.

Digital Operator Display		Minor Fault Name
<i>THo</i>	THo	Thermistor Disconnect The thermistor used to detect motor temperature has become disconnected.
<b>Cause</b>		<b>Possible Solutions</b>
The motor thermistor is not connected properly.		Check the thermistor wiring.

Digital Operator Display		Minor Fault Name
<i>TrPC</i>	TrPC	IGBT Maintenance Time (90%) IGBTs have reached 90% of their expected performance life.
<b>Cause</b>		<b>Possible Solutions</b>
IGBTs have reached 90% of their expected performance life.		Replace the drive.



Digital Operator Display		Minor Fault Name
UL3	UL3	Undertorque Detection 1
		Drive output current (or torque in OLV, CLV, AOLV/PM, and CLV/PM) less than L6-02 for longer than L6-03 time.
<b>Cause</b>		<b>Possible Solutions</b>
Inappropriate parameter settings.		Check parameters L6-02 and L6-03.
Load has dropped or decreased significantly.		Check for broken parts in the transmission system.

Digital Operator Display		Minor Fault Name
UL4	UL4	Undertorque Detection 2
		Drive output current (or torque in OLV, CLV, AOLV/PM, and CLV/PM) less than L6-05 for longer than L6-06 time.
<b>Cause</b>		<b>Possible Solutions</b>
Inappropriate parameter settings.		Check parameters L6-05 and L6-06.
The load has dropped or decreased significantly.		Check for broken parts in the transmission system.

Digital Operator Display		Minor Fault Name
Uv	Uv	Undervoltage
		One of the following conditions was true when the drive was stopped and a Run command was entered: <ul style="list-style-type: none"> <li>DC bus voltage dropped below the level specified in L2-05.</li> <li>Contactors to suppress inrush current in the drive were opened.</li> <li>Low voltage in the control drive input power. This alarm outputs only if L2-01 is not 0 and DC bus voltage is under L2-05.</li> </ul>
<b>Cause</b>		<b>Possible Solutions</b>
Phase loss in the drive input power.		Check for wiring errors in the main circuit drive input power. Correct the wiring.
Loose wiring in the drive input power terminals.		<ul style="list-style-type: none"> <li>Check for loose terminals.</li> <li>Ensure the terminals have been properly tightened.</li> <li>Apply the tightening torque to the terminals.</li> </ul>
There is a problem with the drive input power voltage.		<ul style="list-style-type: none"> <li>Check the voltage.</li> <li>Lower the voltage of the drive input power so that it is within the limits listed in the specifications.</li> </ul>
Drive internal circuitry is worn.		<ul style="list-style-type: none"> <li>Check the maintenance time for the capacitors (U4-05).</li> <li>Replace either the control board or the entire drive if U4-05 exceeds 90%. For instructions on replacing the control board, contact Yaskawa or your nearest sales representative.</li> </ul>
The drive input power transformer is too small and voltage drops when the power is switched on.		<ul style="list-style-type: none"> <li>Check for an alarm when the magnetic contactor, line breaker, and leakage breaker are closed.</li> <li>Check the capacity of the drive input power transformer.</li> </ul>
Air inside the drive is too hot.		Check the temperature inside the drive.
The CHARGE light is broken or disconnected.		Replace either the control board or the entire drive. For instructions on replacing the control board, contact Yaskawa or your nearest sales representative.

Digital Operator Display		Minor Fault Name
voF	voF	Output Voltage Detection Fault
		There is a problem with the output voltage.
<b>Cause</b>		<b>Possible Solutions</b>
Hardware is damaged.		Replace either the control board or the entire drive. For instructions on replacing the control board, contact Yaskawa or your nearest sales representative.

## 2.6 Operator Programming Errors

### ◆ Operator Programming Error Codes, Causes, and Possible Solutions

An Operator Programming Error (oPE) occurs when a contradictory parameter is set or an individual parameter is set to an inappropriate value.

The drive will not operate until the parameter or parameters causing the problem are set correctly. An oPE, however, does not trigger an alarm or fault output. If an oPE occurs, investigate the cause and refer to [Table 2.12](#) for the appropriate action. When an oPE appears on the operator display, press the ENTER button to view U1-18 and see which parameter is causing the oPE.

**Table 2.12 oPE Codes, Causes, and Possible Solutions**

Digital Operator Display		Error Name
oPE01	oPE01	Drive Capacity Setting Fault
		Drive capacity and the value set to o2-04 do not match.
<b>Cause</b>		<b>Possible Solutions</b>
The drive model selection (o2-04) and the actual capacity of the drive are not the same.		Correct the value set to o2-04.

Digital Operator Display		Error Name
oPE02	oPE02	Parameter Range Setting Error
		Use U1-18 to find parameters set outside the range.
<b>Cause</b>		<b>Possible Solutions</b>
Parameters were set outside the possible setting range.		Set parameters to the proper values.
<b>Note:</b> When multiple errors occur simultaneously, other errors are given precedence over oPE02.		

Digital Operator Display		Error Name
oPE03	oPE03	Multi-Function Input Selection Error
		A contradictory setting is assigned to multi-function contact inputs H1-01 to H1-08.
<b>Cause</b>		<b>Possible Solutions</b>
<ul style="list-style-type: none"> <li>The same function is assigned to two multi-function inputs.</li> <li>Excludes “Not used” and “External Fault.”</li> </ul>		<ul style="list-style-type: none"> <li>Ensure all multi-function inputs are assigned to different functions.</li> <li>Re-enter the multi-function settings to ensure this does not occur.</li> </ul>
The Up command was set but the Down command was not, or vice versa (settings 10 vs. 11).		Properly set the functions that required for use in combination with other functions.
The Up 2 command was set but the Down 2 command was not, or vice versa (settings 75 vs. 76).		
<ul style="list-style-type: none"> <li>Run/Stop command for a 2-wire sequence was set (H1-□□ = 42), but Forward/Reverse command (H1-□□ = 43) was not.</li> <li>“Drive Enable” is set to multi-function input S1 or S2 (H1-01 = 6A or H1-02 = 6A).</li> </ul>		Properly set the functions that required for use in combination with other functions.
Two of the following functions are set simultaneously: <ul style="list-style-type: none"> <li>Up/Down Command (10 vs. 11)</li> <li>Up 2/Down 2 Command (75 vs. 76)</li> <li>Hold Accel/Decel Stop (A)</li> <li>Analog Frequency Reference Sample/Hold (1E)</li> <li>Offset Frequency 1, 2, 3 Calculations (44, 45, 46)</li> </ul>		<ul style="list-style-type: none"> <li>Check if contradictory settings have simultaneously been assigned to the multi-function input terminals.</li> <li>Correct setting errors.</li> </ul>
The Up/Down command (10, 11) and PID control (b5-01) are enabled simultaneously.		Set b5-01 to 0 to disable control PID or disable the Up/Down command.

<p>Settings for N.C. and N.O. input for the following functions were selected simultaneously:</p> <ul style="list-style-type: none"> <li>External Search Command 1 and External Search Command 2 (61 vs. 62)</li> <li>Fast Stop N.O. and Fast Stop N.C. (15 vs. 17)</li> <li>KEB for Momentary Power Loss and High Slip Braking (65, 66, 7A, 7B vs. 68)</li> <li>Motor Switch Command and Accel/Decel Time 2 (16 vs. 1A)</li> <li>KEB Command 1 and KEB Command 2 (65, 66 vs. 7A, 7B)</li> <li>FWD Run Command (or REV) and FWD/REV Run Command (2-wire) (40, 41 vs. 42, 43)</li> <li>External DB Command and Drive Enable (60 vs. 6A)</li> <li>Motor Switch Command and Up 2/Down 2 Command (16 vs. 75, 76)</li> </ul>	<ul style="list-style-type: none"> <li>Check if contradictory settings have simultaneously been assigned to the multi-function input terminals.</li> <li>Correct setting errors.</li> </ul>
<p>One of the following settings was entered while H1-□□ = 2 (External Reference 1/2):</p> <ul style="list-style-type: none"> <li>b1-15 = 4 (Pulse Train Input) but the pulse train input selection is not set for the frequency reference (H6-01 &gt; 0)</li> <li>b1-15 or b1-16 set to 3 but no option card is connected</li> <li>Although b1-15 = 1 (Analog Input) and H3-02 or H3-10 are set to 0 (Frequency Bias)</li> </ul>	<p>Correct the settings for the multi-function input terminal parameters.</p>
<p>H2-□□ is set to 38 (Drive Enabled) and H1-□□ is not set to 6A (Drive Enable).</p>	
<p>H1-□□ is set to 7E (Direction Detection) and H6-01 is not set to 3 (for V/f Control with PG using terminal RP as speed feedback input).</p>	

Digital Operator Display		Error Name
<i>oPE04</i>	oPE04	Initialization Required
<b>Cause</b>		<b>Possible Solutions</b>
<p>The drive, control board, or terminal board have been replaced and the parameter settings between the control board and the terminal board no longer match.</p>		<p>Set A1-03 to 555o to load the parameter settings stored in the terminal board to the drive. Initialize parameters after drive replacement by setting A1-03 to 1110 or 2220.</p>

Digital Operator Display		Error Name
<i>oPE05</i>	oPE05	Run Command/Frequency Reference Source Selection Error
<b>Cause</b>		<b>Possible Solutions</b>
<p>Frequency reference is assigned to an option card (b1-01 = 3) and an input option card is not connected to the drive.</p>		<p>Reconnect the input option card to the drive.</p>
<p>The Run command is assigned to an option card (b1-02 = 3) and an input option card is not connected to the drive.</p>		
<p>Frequency reference is assigned to the pulse train input (b1-01 = 4) and terminal RP is not set for frequency reference input (H6-01 &gt; 0)</p>		<p>Set H6-01 to 0.</p>
<p>Although the digital card input is set for BCD special for a 5-digit input (F3-01 = 6), the data length is set for 8-bit or 12-bit (F3-03 = 0, 1).</p>		<p>Set F3-03 to 2 to set the input data for 16-bit.</p>
<p>The following values have been set while an AI-A3 option card is installed:</p> <ul style="list-style-type: none"> <li>The source of frequency reference setting is assigned to an option card (b1-01 = 3).</li> <li>The action for the analog card is set for separate terminal input (F2-01 = 0).</li> </ul>		<p>Properly set parameters.</p>

Digital Operator Display		Error Name
<i>oPE06</i>	oPE06	Control Method Selection Error
<b>Cause</b>		<b>Possible Solutions</b>
<p>A control mode has been selected that requires a PG option card to be installed, but no PG encoder is installed (A1-02 = 1, 3, or 7).</p>		<ul style="list-style-type: none"> <li>Connect a PG option card.</li> <li>Correct the value set to A1-02.</li> </ul>

Digital Operator Display		Error Name
<i>oPE07</i>	oPE07	Multi-Function Analog Input Selection Error
<b>Cause</b>		<b>Possible Solutions</b>
		<p>A contradictory setting is assigned to multi-function analog inputs H3-02, H3-06, or H3-10 and PID functions conflict.</p>

## 2.6 Operator Programming Errors

At least two analog input terminals are set to the same function (i.e., at least two of these parameters have the same setting: H3-02, H3-06, or H3-10).	Change the settings to H3-02, H3-06, and H3-10 so that functions no longer conflict. <b>Note:</b> Both 0 (Frequency Reference Bias) and F (Not Used) can be set to H3-02, H3-06, and H3-10 simultaneously.
The following simultaneous contradictory settings: <ul style="list-style-type: none"> <li>H3-02, H3-06, or H3-10 = B (PID Feedback) while H6-01 (Pulse Train Input) = 1 (PID Feedback)</li> <li>H3-02, H3-06, or H3-10 = C (PID Target Value) while H6-01 = 2 (pulse train input sets the PID target value)</li> <li>H3-02, H3-06, or H3-10 = C (PID Target Value) while b5-18 = 1 (enables b5-19 as the target PID value)</li> <li>H6-01 = 2 (PID target) while b5-18 = 1 (enables b5-19 as the target PID value)</li> </ul>	Disable one of the PID selections.

Digital Operator Display		Error Name
$\alpha P E 0 8$	oPE08	Parameter Selection Error
Cause		Possible Solutions
Attempted to use a function that is not valid for the selected control mode.		Check the motor control method and the functions available.
In OLV, n2-02 is longer than n2-03		Adjust parameter values so n2-02 is shorter than n2-03.
In OLV, C4-02 is longer than C4-06		Adjust parameter values so C4-02 is shorter than C4-06.
The following settings have occurred in OLV/PM: <ul style="list-style-type: none"> <li>E5-03 does not equal 0</li> <li>E5-09 and E5-24 are both equal to 0, or neither equals 0</li> </ul>		<ul style="list-style-type: none"> <li>Set E5-09 or E5-24 to the correct value, and set the other to 0.</li> <li>Set the motor rated current for PM to 0 (E5-03).</li> </ul>
b1-14 (Phase Order Selection) is set to 1 (Switch phase order) when using a PG option card.		Correct the parameter settings.
In AOLV/PM High Frequency Injection is disabled (n8-57 = 0) and the minimum frequency (E1-09) is set lower than 1/20 of the base frequency setting.		Correct the parameter settings.
<b>Note:</b> Use U1-18 to find parameters that are set outside the specified setting range. When multiple errors occur simultaneously, other errors are given precedence over oPE08.		

Digital Operator Display		Error Name
$\alpha P E 0 9$	oPE09	PID Control Selection Fault
Cause		Possible Solutions
The following simultaneous contradictory settings have occurred: <ul style="list-style-type: none"> <li>b5-15 is not set to 0.0 (PID Sleep Function Operation Level)</li> <li>The stopping method is set to either DC Injection Braking or coast to stop with a timer (b1-03 = 2 or 3).</li> </ul>		<ul style="list-style-type: none"> <li>Set b5-15 to a value other than 0.0.</li> <li>Set the stopping method to coast to stop or ramp to stop (b1-03 = 0 or 1).</li> </ul>
b5-01 is set to 1 or 2, enabling PID control, but the lower limit for the frequency reference (d2-02) is not set to 0 while reverse output is enabled (b5-11 = 1).		Correct the parameter settings.
b5-01 is set to 3 or 4, enabling PID control, but the lower limit for the frequency reference (d2-01) is not 0.		Correct the parameter settings.

Digital Operator Display		Error Name
$\alpha P E 1 0$	oPE10	V/f Data Setting Error
Cause		Possible Solutions
		One of the following setting errors has occurred: <ul style="list-style-type: none"> <li>E1-04 <math>\geq</math> E1-06 E1-06 <math>\geq</math> E1-07 E1-07 <math>\geq</math> E1-09 or E1-09 <math>\geq</math> E1-11</li> <li>E3-04 <math>\geq</math> E3-06 E3-06 <math>\geq</math> E3-07 E3-07 <math>\geq</math> E3-09 or E3-09 <math>\geq</math> E3-11</li> </ul>

V/f pattern setting error.	Correct the settings for E1-04, E1-06, E1-07, E1-09, and E1-11. For motor 2, correct E3-04, E3-06, E3-07, E3-09, and E3-11.
----------------------------	--

Digital Operator Display	Error Name
<i>oPE 11</i>	oPE11
<b>Cause</b>	<b>Possible Solutions</b>
The following simultaneous contradictory settings have occurred: C6-05 > 6 and C6-04 > C6-03 (carrier frequency lower limit is greater than the upper limit). If C6-05 ≤ 6, the drive operates at C6-03. The upper and lower limits between C6-02 and C6-05 are contradictory.	Carrier Frequency Setting Error Correct the setting for the carrier frequency. Correct the parameter settings.

Digital Operator Display	Error Name
<i>oPE 13</i>	oPE13
<b>Cause</b>	<b>Possible Solutions</b>
Scaling for the pulse train monitor is set to 0 (H6-07 = 0) while H6-06 is not set to 101, 102, 105, or 116.	Pulse Monitor Selection Error Incorrect setting of monitor selection for pulse train (H6-06). Change scaling for the pulse train monitor or set H6-06 to 101, 102, 105, or 116.

Digital Operator Display	Error Name
<i>oPE 15</i>	oPE15
<b>Cause</b>	<b>Possible Solutions</b>
Torque Control is enabled (d5-01 = 1) while the Speed/Torque Control switch function is assigned to a digital input (H1-□□ = 71). Either d5-01 is set to 1 to enable Torque Control, or the Speed/Torque Control switch is assigned to a digital input H1-□□ = 71, while at the same time: <ul style="list-style-type: none"> <li>• Feed Forward is enabled (n5-01 = 1), or</li> <li>• Droop Control is enabled (b7-01 ≠ 0), or</li> <li>• Intelligent Stall Prevention or Intelligent Stall Prevention 2 is enabled (L3-04 = 2 or 5), or</li> <li>• A digital input is set for the power KEB 1 or KEB 2 (H1-□□ = 7A or 7B)</li> </ul>	Torque Control Setting Error Parameter settings that are not allowed in combination with Torque Control have been set. Correct the parameter settings.

Digital Operator Display	Error Name
<i>oPE 16</i>	oPE16
<b>Cause</b>	<b>Possible Solutions</b>
In AOLV/PM, the automatically calculated energy saving coefficients are out of the allowable range.	Energy Savings Constants Error Check and correct the motor data in E5 parameters.

Digital Operator Display	Error Name
<i>oPE 18</i>	oPE18
<b>Cause</b>	<b>Possible Solutions</b>
One of the following errors occurred while online tuning was enabled in OLV (A1-02 = 2): <ul style="list-style-type: none"> <li>• E2-02 was set below 30% of the original default value</li> <li>• E2-06 was set below 50% of the original default value</li> <li>• E2-03 = 0</li> </ul>	Online Tuning Parameter Setting Error Parameters controlling online tuning are not set correctly. Set E2-02, E2-03, and E2-06 to the correct values.

## 2.7 Auto-Tuning Fault Detection

When the Auto-Tuning faults shown below are detected, the fault is displayed on the operator and the motor coasts to a stop. Auto-Tuning faults do not trigger a multi-function terminal set for fault or alarm output.

An End□ error indicates that although Auto-Tuning has successfully completed, there is some discrepancy in the calculations. If an End□ error occurs, check for the cause of the error using the table below, and perform Auto-Tuning again after fixing the problem. Start the application if no problem can be diagnosed despite the existence of the End□ error.

### ◆ Auto-Tuning Codes, Causes, and Possible Solutions

Table 2.13 Auto-Tuning Codes, Causes, and Possible Solutions

Digital Operator Display		Error Name
$\text{End1}$	End1	Excessive V/f Setting (detected only during Rotational Auto-Tuning and displayed after Auto-Tuning is complete)
<b>Cause</b>		<b>Possible Solutions</b>
The torque reference exceeded 20% during Auto-Tuning.		<ul style="list-style-type: none"> <li>• Prior to Auto-Tuning, verify the information on the motor nameplate.</li> <li>• Enter proper values from motor nameplate to parameters T1-03 to T1-05 and repeat Auto-Tuning.</li> <li>• If possible, disconnect the motor from the load and perform Auto-Tuning. If the load cannot be uncoupled, use the current Auto-Tuning results.</li> </ul>
The results from Auto-Tuning the no-load current exceeded 80%.		
Digital Operator Display		Error Name
$\text{End2}$	End2	Motor Iron-Core Saturation Coefficient (detected only during Rotational Auto-Tuning and displayed after Auto-Tuning is complete)
<b>Cause</b>		<b>Possible Solutions</b>
Motor data entered during Auto-Tuning was incorrect.		<ul style="list-style-type: none"> <li>• Make sure the data entered to the T1 parameters match the information written on the motor nameplate.</li> <li>• Restart Auto-Tuning and enter the correct information.</li> <li>• Check and correct faulty motor wiring.</li> <li>• Disconnect the motor from machine and perform Rotational Auto-Tuning.</li> </ul>
Results from Auto-Tuning are outside the parameter setting range, assigning the iron-core saturation coefficients (E2-07 and E2-08) to temporary values.		
Digital Operator Display		Error Name
$\text{End3}$	End3	Rated Current Setting Alarm (displayed after Auto-Tuning is complete)
<b>Cause</b>		<b>Possible Solutions</b>
The correct current rating printed on the motor nameplate was not entered into T1-04.		<ul style="list-style-type: none"> <li>• Check the setting of parameter T1-04.</li> <li>• Check the motor data and repeat Auto-Tuning.</li> </ul>
Digital Operator Display		Error Name
$\text{End4}$	End4	Adjusted Slip Calculation Error
<b>Cause</b>		<b>Possible Solutions</b>
The calculated slip is outside the allowable range.		<ul style="list-style-type: none"> <li>• Make sure the data entered for Auto-Tuning is correct.</li> <li>• If possible, perform Rotational Auto-Tuning. If not possible, perform Stationary Auto-Tuning 2.</li> </ul>
Digital Operator Display		Error Name
$\text{End5}$	End5	Resistance Tuning Error
<b>Cause</b>		<b>Possible Solutions</b>
The calculated resistance value is outside the allowable range.		<ul style="list-style-type: none"> <li>• Double-check the data entered for the Auto-Tuning process.</li> <li>• Check the motor and motor cable connection for faults.</li> </ul>
Digital Operator Display		Error Name
$\text{End6}$	End6	Leakage Inductance Alarm
<b>Cause</b>		<b>Possible Solutions</b>
The calculated leakage inductance value is outside the allowable range.		Double-check the data entered for the Auto-Tuning process.

Digital Operator Display		Error Name
End7	End7	No-Load Current Alarm
Cause		Possible Solutions
The entered no-load current value was outside the allowable range.		Check and correct faulty motor wiring.
Auto-Tuning results were less than 5% of the motor rated current.		Double-check the data entered for the Auto-Tuning process.

Digital Operator Display		Error Name
Er-01	Er-01	Motor Data Error
Cause		Possible Solutions
Motor data or data entered during Auto-Tuning was incorrect.		<ul style="list-style-type: none"> <li>Check that the motor data entered to T1 parameters matches motor nameplate input before Auto-Tuning.</li> <li>Restart Auto-Tuning and enter the correct information.</li> </ul>
Motor output power and motor-rated current settings (T1-02 and T1-04) do not match.		<ul style="list-style-type: none"> <li>Check the drive and motor capacities.</li> <li>Correct the settings of parameters T1-02 and T1-04.</li> </ul>
Motor rated current and detected no-load current are inconsistent.		<ul style="list-style-type: none"> <li>Check the motor rated current and no-load current.</li> <li>Correct the settings of parameters T1-04 and E2-03.</li> </ul>
Base frequency and motor rated speed (T1-05 and T1-07) do not match.		<ul style="list-style-type: none"> <li>Correct the settings of parameters T1-05 and T1-07.</li> <li>Check that the correct number of poles were entered to T1-06.</li> </ul>

Digital Operator Display		Error Name
Er-02	Er-02	Minor Fault
Cause		Possible Solutions
An alarm was triggered during Auto-Tuning.		Exit the Auto-Tuning menu, check the alarm code, remove the alarm cause, and repeat Auto-Tuning.

Digital Operator Display		Error Name
Er-03	Er-03	STOP Button Input
Cause		Possible Solutions
Auto-Tuning canceled by pressing STOP button.		Auto-Tuning did not complete properly. Restart Auto-Tuning.

Digital Operator Display		Error Name
Er-04	Er-04	Line-to-Line Resistance Error
Cause		Possible Solutions
Motor data entered during Auto-Tuning was incorrect.		<ul style="list-style-type: none"> <li>Make sure the data entered to the T1 parameters match the information written on the motor nameplate.</li> <li>Restart Auto-Tuning and enter the correct information.</li> </ul>
Results from Auto-Tuning are outside the parameter setting range or the tuning process took too long.		Check and correct faulty motor wiring.
Faulty motor cable or cable connection.		

Digital Operator Display		Error Name
Er-05	Er-05	No-Load Current Error
Cause		Possible Solutions
Motor data entered during Auto-Tuning was incorrect.		<ul style="list-style-type: none"> <li>Make sure the data entered to the T1 parameters match the information written on the motor nameplate.</li> <li>Restart Auto-Tuning and enter the correct information.</li> </ul>
Results from Auto-Tuning are outside the parameter setting range or the tuning process took too long.		<ul style="list-style-type: none"> <li>Check and correct faulty motor wiring.</li> <li>Perform Rotational Auto-Tuning.</li> </ul>
The load was too high during Rotational Auto-tuning.		<ul style="list-style-type: none"> <li>Disconnect the motor from machine and restart Auto-Tuning. If motor and load cannot be uncoupled make sure the load is lower than 30%.</li> <li>If a mechanical brake is installed, make sure it is fully lifted during tuning.</li> </ul>

## 2.7 Auto-Tuning Fault Detection

Digital Operator Display		Error Name
<i>Er-08</i>	Er-08	Rated Slip Error
Cause		Possible Solutions
Motor data entered during Auto-Tuning was incorrect.		<ul style="list-style-type: none"> <li>Make sure the data entered to the T1 parameters match the information written on the motor nameplate.</li> <li>Restart Auto-Tuning and enter the correct information.</li> </ul>
Results from Auto-Tuning are outside the parameter setting range or the tuning process took too long.		<ul style="list-style-type: none"> <li>Check and correct faulty motor wiring.</li> <li>Perform Rotational Auto-Tuning.</li> </ul>
The load was too high during rotational Auto-tuning.		<ul style="list-style-type: none"> <li>Disconnect the motor from machine and restart Auto-Tuning. If motor and load cannot be uncoupled make sure the load is lower than 30%.</li> <li>If a mechanical brake is installed, make sure it is fully lifted during tuning.</li> </ul>

Digital Operator Display		Error Name
<i>Er-09</i>	Er-09	Acceleration Error
Cause		Possible Solutions
The motor did not accelerate for the specified acceleration time.		<ul style="list-style-type: none"> <li>Increase the acceleration time (C1-01).</li> <li>Disconnect the machine from the motor if possible.</li> </ul>
Torque limit when motoring is too low (L7-01 and L7-02).		<ul style="list-style-type: none"> <li>Check L7-01 and L7-02 settings.</li> <li>Increase the setting.</li> </ul>
The load was too high during Rotational Auto-Tuning.		<ul style="list-style-type: none"> <li>Disconnect the motor from machine and restart Auto-Tuning. If motor and load cannot be uncoupled make sure the load is lower than 30%.</li> <li>If a mechanical brake is installed, make sure it is fully lifted during tuning.</li> </ul>

Digital Operator Display		Error Name
<i>Er-10</i>	Er-10	Motor Direction Error
Cause		Possible Solutions
The encoder signal lines are not properly connected to the drive.		Check and correct wiring to the PG encoder.
Motor direction and PG direction are opposite.		Check the motor speed monitor U1-05 while manually turning the motor forward. If the sign displayed is negative, change the setting of parameter F1-05.
The load pulled the motor in the opposite direction of the speed reference and the torque exceeded 100%.		Uncouple the motor from the load and restart Auto-Tuning.

Digital Operator Display		Error Name
<i>Er-11</i>	Er-11	Motor Speed Fault
Cause		Possible Solutions
Torque reference is too high.		<ul style="list-style-type: none"> <li>Increase the acceleration time (C1-01).</li> <li>Disconnect the machine from the motor if possible.</li> </ul>

Digital Operator Display		Error Name
<i>Er-12</i>	Er-12	Current Detection Error
Cause		Possible Solutions
One of the motor phases is missing: (U/T1, V/T2, W/T3).		Check motor wiring and correct any problems.
The current exceeded the current rating of the drive.		<ul style="list-style-type: none"> <li>Check motor wiring for a short between motor lines.</li> <li>Close any magnetic contactors used between motors.</li> </ul>
The current is too low.		<ul style="list-style-type: none"> <li>Replace the control board or the entire drive. For instructions on replacing the control board, contact Yaskawa or your nearest sales representative.</li> </ul>
Attempted Auto-Tuning without motor connected to the drive.		Connect the motor and restart Auto-Tuning.
Current detection signal error.		Replace the control board or the entire drive. For instructions on replacing the control board, contact Yaskawa or your nearest sales representative.



Digital Operator Display		Error Name
Er-13	Er-13	Leakage Inductance Error
<b>Cause</b>		<b>Possible Solutions</b>
Drive was unable to complete tuning for leakage inductance within 300 seconds.		<ul style="list-style-type: none"> <li>• Check all wiring and correct any mistakes.</li> <li>• Check the motor rated current value written on the motor nameplate and enter the correct value to T1-04.</li> </ul>

Digital Operator Display		Error Name
Er-14	Er-14	Motor Speed Error 2
<b>Cause</b>		<b>Possible Solutions</b>
The motor speed exceeded twice the amplitude of speed reference during Inertia Tuning.		Reduce the ASR gain set to C5-01.

Digital Operator Display		Error Name
Er-15	Er-15	Torque Saturation Error
<b>Cause</b>		<b>Possible Solutions</b>
The output torque reached the torque limit set in L7-01 through L7-04 during Inertia Tuning.		<ul style="list-style-type: none"> <li>• Increase the torque limits in L7-01 through L7-04 within reasonable limits.</li> <li>• Reduce the test signal amplitude in T3-01 and restart Auto-Tuning. If necessary, reduce the test signal frequency (T3-02) and restart Auto-Tuning.</li> </ul>

Digital Operator Display		Error Name
Er-16	Er-16	Inertia Detection Error
<b>Cause</b>		<b>Possible Solutions</b>
The inertia identified by the drive was abnormally small or abnormally large during Inertia Tuning.		<ul style="list-style-type: none"> <li>• Reduce the test signal amplitude in T3-01 and restart Auto-Tuning. If necessary, reduce the test signal frequency (T3-02) and restart Auto-Tuning.</li> <li>• Check the basic motor inertia value entered to T3-03.</li> </ul>

Digital Operator Display		Error Name
Er-17	Er-17	Reverse Prohibited Error
<b>Cause</b>		<b>Possible Solutions</b>
Drive is prohibited from rotating the motor in reverse while attempting to perform Inertia Tuning.		<ul style="list-style-type: none"> <li>• Inertia Auto-Tuning cannot be performed if the drive is restricted from rotating in reverse.</li> <li>• Assuming it is acceptable for the application to rotate in reverse, set b1-04 to 0 and then perform Inertia Tuning.</li> </ul>

Digital Operator Display		Error Name
Er-18	Er-18	Induction Voltage Error
<b>Cause</b>		<b>Possible Solutions</b>
The result of Back EMF Constant Tuning (induced voltage) exceeds the allowable setting range.		Double-check the data entered to the T2-□□ parameters and restart Auto-Tuning.

Digital Operator Display		Error Name
Er-19	Er-19	PM Inductance Error
<b>Cause</b>		<b>Possible Solutions</b>
The induced voltage constant attempted to set a value to E5-08 or E5-09 that is outside the allowable range.		Double-check the data entered to the T2-□□ parameters and restart Auto-Tuning.

Digital Operator Display		Error Name
Er-20	Er-20	Stator Resistance Error
<b>Cause</b>		<b>Possible Solutions</b>
Stator resistance tuning attempted to set a value to E5-06 that is outside the allowable setting range.		Double-check the data entered to the T2-□□ parameters and restart Auto-Tuning.

## 2.7 Auto-Tuning Fault Detection

Digital Operator Display		Error Name
Er-21	Er-21	Z Pulse Correction Error
Cause		Possible Solutions
Motor was coasting when Auto-Tuning was performed.		Make sure the motor has stopped completely. Restart Auto-Tuning.
Either the motor or the PG encoder on the motor are not properly wired.		Check the wiring for the motor and the PG encoder. Restart Auto-Tuning.
The direction for the PG encoder is set incorrectly, or the number of pulses set for the PG encoder is wrong.		Check the direction and number of pulses set for the PG encoder. Restart Auto-Tuning.
PG encoder is damaged.		Check the signal output from the PG encoder attached to the motor. Replace the PG if damaged.

## 2.8 Copy Function Related Displays

### ◆ Tasks, Errors, and Troubleshooting

The table below lists the messages and errors that may appear when using the Copy function.

When executing the tasks offered by the Copy function, the operator will indicate the task being performed. When an error occurs, a code appears on the operator to indicate the error. Note that errors related to the Copy function do not trigger a multi-function output terminal that has been set up to close when a fault or alarm occurs. To clear an error, simply press any key on the operator and the error display will disappear.

**Table 2.14** lists the corrective action that can be taken when an error occurs.

- Note:**
1. Whenever using the copy function, the drive should be fully stopped.
  2. The drive will not accept a Run command while the Copy function is being executed.
  3. Parameters can only be saved to a drive when the voltage class, capacity, control mode, and software version match.

**Table 2.14 Copy Function Task and Error Displays**

Digital Operator Display		Task
<i>CoPY</i>	CoPy	Writing Parameter Settings (flashing)
<b>Cause</b>		<b>Possible Solutions</b>
Parameters are being written to the drive.		This is not an error.
Digital Operator Display		Task
<i>CPEr</i>	CPEr	Control Mode Mismatch
<b>Cause</b>		<b>Possible Solutions</b>
Control mode of the parameters to be loaded onto the drive and the control mode set to the drive do not match.		<ul style="list-style-type: none"> <li>• Verify the control mode for the parameters to be loaded onto the drive and the control mode on drive to which those parameters will be written.</li> <li>• Set the same control mode using parameter A1-02 and retry.</li> </ul>
Digital Operator Display		Task
<i>CPyE</i>	CPyE	Error Writing Data
<b>Cause</b>		<b>Possible Solutions</b>
Failed writing parameters		Attempt to write parameters again.
Digital Operator Display		Task
<i>CSEr</i>	CSEr	Copy Unit Error
<b>Cause</b>		<b>Possible Solutions</b>
Hardware fault		Replace the operator or the USB Copy Unit.
Digital Operator Display		Task
<i>dFPS</i>	dFPS	Drive Model Mismatch
<b>Cause</b>		<b>Possible Solutions</b>
The drives used in the copy and write process are not the same model.		<ul style="list-style-type: none"> <li>• Verify the model number of the drive from which the parameters were copied and the model of the drive to which those parameters will be written.</li> <li>• Make sure the two drives are the same model and have the same software version.</li> </ul>
• The drive from which the parameters were copied is a different model.		
• The drive to be written to is a different model.		
Digital Operator Display		Task
<i>End</i>	End	Task Complete
<b>Cause</b>		<b>Possible Solutions</b>
Finished reading, writing, or verifying parameters.		This is not an error.
Digital Operator Display		Task
<i>iFEr</i>	iFEr	Communication Error
<b>Cause</b>		<b>Possible Solutions</b>
A communication error occurred between the drive and the operator or the USB copy unit.		Check the cable connection.

## 2.8 Copy Function Related Displays

A non-compatible cable is being used to connect the USB Copy Unit and the drive.		Use the cable originally packaged with the USB Copy Unit.
Digital Operator Display		Task
<i>ndAf</i>	ndAT	Model, Voltage Class, Capacity Mismatch
Cause		Possible Solutions
The drive from which the parameters were copied and the drive to which the parameters will be written have different electrical specifications, capacities, are set to different control modes, or are different models.		Make sure model numbers and specifications are the same for both drives.
The device being used to write the parameters is blank and does not have any parameters saved on it.		Make sure all connections are correct, and copy the parameter settings onto the USB Copy Unit or the operator.
Digital Operator Display		Task
<i>rdEr</i>	rdEr	Error Reading Data
Cause		Possible Solutions
Failed while attempting to read parameter settings from the drive.		Press and hold the READ key on the USB Copy Unit for at least one second to have the unit read parameters from the drive.
Digital Operator Display		Task
<i>rEd</i>	rEAd	Reading Parameter Settings (flashing)
Cause		Possible Solutions
Displayed while the parameter settings are being read onto the USB Copy Unit.		This is not an error.
Digital Operator Display		Task
<i>vAEr</i>	vAEr	Voltage Class, Capacity Mismatch
Cause		Possible Solutions
The drive from which the parameters were copied and the drive on which the Verify mode is being performed have different electrical specifications or are a different capacity.		Make sure electrical specifications and capacities are the same for both drives.
Digital Operator Display		Task
<i>vFyE</i>	vFyE	Parameter settings in the drive and those saved to the copy function are not the same
Cause		Possible Solutions
Indicates that parameter settings that have been Read and loaded onto the Copy Unit or Digital Operator are different.		To synchronize parameters, either write the parameters saved on the USB Copy Unit or digital operator onto the drive, or Read the parameter settings on the drive onto the USB Copy Unit.
Digital Operator Display		Task
<i>vrFy</i>	vrFy	Comparing Parameter Settings (flashing)
Cause		Possible Solutions
The Verify mode has confirmed that parameters settings on the drive and parameters read to the copy device are identical.		This is not an error.

## 2.9 Diagnosing and Resetting Faults

When a fault occurs and the drive stops, follow the instructions below to remove whatever conditions triggered the fault, then restart the drive.

**Note:** An oC/SC fault will be displayed in the event of an IGBT failure. It may not be possible to reset this fault until the IGBT problem is corrected.

### ◆ Fault Occurs Simultaneously with Power Loss

**WARNING! Electrical Shock Hazard.** Ensure there are no short circuits between the main circuit terminals (R/L1, S/L2, and T/L3) or between the ground and main circuit terminals before restarting the drive. Failure to comply may result in serious injury or death and will cause damage to equipment.

1. Turn on the drive input power.
2. Use monitor parameters U2-□□ to display data on the operating status of the drive just before the fault occurred.
3. Remove the cause of the fault and reset.







**Note:**

1. To find out what faults were triggered, check the fault history in U2-02. Information on drive status when the fault occurred such as the frequency, current, and voltage can be found in U2-03 through U2-20. [Refer to Viewing Fault Trace Data After Fault on page 221](#) for information on how to view fault data.
2. When the fault continues to be displayed after cycling power, remove the cause of the fault and reset.

### ◆ If the Drive Still has Power After a Fault Occurs

1. Look at the digital operator for information on the fault that occurred.
2. [Refer to Fault Displays, Causes, and Possible Solutions on page 182.](#)
3. Reset the fault. [Refer to Fault Reset Methods on page 222.](#)

### ◆ Viewing Fault Trace Data After Fault

Step		Display/Result
1. Turn on the drive input power. The first screen displays.	→	<pre> - MODE - DRV Rdy   FREF (OPR) U1-01= 0.00Hz U1-02= 0.00Hz[LSEQ U1-03= 0.00A [LREF JOG FWD FWD/REV                     </pre>
2. Press  or  until the monitor screen is displayed.	→	<pre> - MODE - DRV Rdy   Monitor Menu U1-01= 0.00Hz U1-02= 0.00Hz[LSEQ U1-03= 0.00A [LREF JOG FWD FWD/REV                     </pre>
3. Press  to display the parameter setting screen.	→	<pre> -MONITR- DRV Rdy   Monitor U1-01= 0.00Hz U1-02= 0.00Hz[LSEQ U1-03= 0.00A [LREF JOG FWD FWD/REV                     </pre>
4. Press  and  to scroll to monitor U2-02. The fault code shown in U2-02 is the fault that occurred most recently.	→	<pre> - MONITR - DRV Rdy   Last Fault U2-02= oC U2-03= 0.00Hz[LSEQ U2-04= 0.00Hz[LREF JOG FWD FWD/REV                     </pre>
5. Press  to view drive status information when fault occurred. Parameters U2-03 through U2-20 help determine the cause of a fault. Parameters to be monitored differ depending on the control mode.	→	<pre> - MONITR - DRV Rdy   Frequency Ref U2-03= 0.00Hz U2-04= 0.00Hz[LSEQ U2-05= 0.00A [LREF JOG FWD FWD/REV ↓ ↓ ↓ - MONITR - DRV Rdy   Heatsink Temp U2-20= XX °C U2-01= ---- [LSEQ U2-02= ---- [LREF JOG FWD FWD/REV                     </pre>

## 2.9 Diagnosing and Resetting Faults

### ◆ Fault Reset Methods

When a fault occurs, the cause of the fault must be removed and the drive must be restarted. The table below lists the different ways to restart the drive.

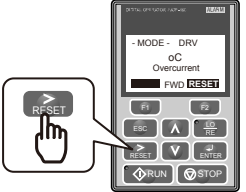
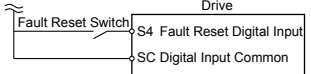
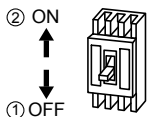
After the Fault Occurs	Procedure	
Fix the cause of the fault, restart the drive, and reset the fault	Press  on the digital operator.	
Resetting via Fault Reset Digital Input S4	Close then open the fault signal digital input via terminal S4. S4 is set for "Fault Reset" as default (H1-04 = 14).	
Turn off the main power supply if the above methods do not reset the fault. Reapply power after the digital operator display has turned off.		

**Note:** If the Run command is present, the drive will disregard any attempts to reset the fault. Remove the Run command before attempting to clear a fault situation.

## 2.10 Troubleshooting without Fault Display

This section describes troubleshooting problems that do not trip an alarm or fault.

The following symptoms indicate that the drive is not set correctly for proper performance with the motor. *Refer to Motor Performance Fine-Tuning on page 174* for guidance on troubleshooting.

- Motor hunting and oscillation
- Poor motor torque
- Poor speed precision
- Poor motor torque and speed response
- Motor noise



### ◆ Common Problems

Common Problems		Page
Cannot Change Parameter Settings		223
Motor Does Not Rotate Properly after Pressing RUN Button or after Entering External Run Command	Motor Does Not Rotate	224
	Motor Rotates in the Opposite Direction from the Run Command	225
	Motor Rotates in One Direction Only	225
Motor is Too Hot		225
Drive Does Not Allow Selection of Rotational Auto-Tuning		226
oPE02 Error Occurs When Lowering the Motor Rated Current Setting		226
Motor Stalls During Acceleration or With Large Loads		226
Drive Frequency Reference Differs from the Controller Frequency Reference Command		227
Excessive Motor Oscillation and Erratic Rotation		227
Deceleration Takes Longer Than Expected with Dynamic Braking Enabled		227
Noise From Drive or Motor Cables When the Drive is Powered On		228
Ground Fault Circuit Interrupter (GFCI) Trips During Run		228
Connected Machinery Vibrates When Motor Rotates	Unexpected Noise from Connected Machinery	228
	Oscillation or Hunting	228
PID Output Fault		229
Insufficient Starting Torque		229
Motor Rotates After the Drive Output is Shut Off (Motor Rotates During DC Injection Braking)		229
Output Frequency is not as High as Frequency Reference		229
Buzzing Sound from Motor at 2 kHz		229
Motor Does Not Restart after Power Loss		230

### ◆ Cannot Change Parameter Settings



Cause	Possible Solutions
The drive is running the motor (i.e., the Run command is present).	<ul style="list-style-type: none"> <li>• Stop the drive and switch over to the Programming Mode.</li> <li>• Most parameters cannot be edited during run.</li> </ul>
The Access Level is set to restrict access to parameter settings.	<ul style="list-style-type: none"> <li>• Set the Access Level to allow parameters to be edited (A1-01 = 2).</li> </ul>
The operator is not in the Parameter Setup Mode (the screen will display “PAR”).	<ul style="list-style-type: none"> <li>• See what mode the operator is currently set for.</li> <li>• Parameters cannot be edited when in the Setup Mode (“STUP”). Switch modes so that “PAR” appears on the screen.</li> </ul>
A multi-function contact input terminal is set to allow or restrict parameter editing (H1-01 through H1-08 = 1B).	<ul style="list-style-type: none"> <li>• When the terminal is open, parameters cannot be edited.</li> <li>• Turn on the multi-function contact input set to 1B.</li> </ul>

## 2.10 Troubleshooting without Fault Display



Cause	Possible Solutions
The wrong password was entered.	<ul style="list-style-type: none"> <li>If the password entered to A1-04 does not match the password saved to A1-05, then drive settings cannot be changed.</li> <li>Reset the password.</li> </ul> If you cannot remember the password: <ul style="list-style-type: none"> <li>Scroll to A1-04. Press  and  simultaneously. Parameter A1-05 will appear.</li> <li>Set a new password to parameter A1-05.</li> </ul>
Undervoltage was detected.	<ul style="list-style-type: none"> <li>Check the drive input power voltage by looking at the DC bus voltage (U1-07).</li> <li>Check all main circuit wiring.</li> </ul>

### ◆ Motor Does Not Rotate Properly after Pressing RUN Button or after Entering External Run Command

#### ■ Motor Does Not Rotate

Cause	Possible Solutions
The drive is not in the Drive Mode.	<ul style="list-style-type: none"> <li>Check if the DRV light on the digital operator is lit.</li> <li>Enter the Drive Mode to begin operating the motor.</li> </ul>
 was pushed.	Stop the drive and check if the correct frequency reference source is selected. If the operator keypad shall be the source, the LO/RE button LED must be on. If the source is REMOTE, it must be off. Take the following steps to solve the problem: <ul style="list-style-type: none"> <li>Push .</li> <li>If o2-01 is set to 0, then the LO/RE button will be disabled.</li> </ul>
Auto-Tuning has just completed.	<ul style="list-style-type: none"> <li>When Auto-Tuning completes, the drive is switched back to the Programming Mode. The Run command will not be accepted unless the drive is in the Drive Mode.</li> <li>Use the digital operator to enter the Drive Mode.</li> </ul>
A Fast Stop was executed and has not yet been reset.	Reset the Fast Stop command.
Settings are incorrect for the source that provides the Run command.	Check parameter b1-02 (Run Command Selection). Set b1-02 so that it corresponds with the correct Run command source. 0: Digital operator 1: Control circuit terminal (default setting) 2: MEMOBUS/Modbus communications 3: Option card
There is faulty wiring in the control circuit terminals.	<ul style="list-style-type: none"> <li>Check the wiring for the control terminal.</li> <li>Correct wiring mistakes.</li> <li>Check the input terminal status monitor (U1-10).</li> </ul>
The drive has been set to accept the frequency reference from the incorrect source.	Check parameter b1-01 (Frequency Reference Selection 1). Set b1-01 to the correct source of the frequency reference. 0: Digital operator 1: Control circuit terminal (default setting) 2: MEMOBUS/Modbus communications 3: Option card 4: Pulse train input (RP)
The terminal set to accept the main speed reference is set to the incorrect voltage and/or current.	If the frequency reference is set at terminal A1, check parameter H3-01 for the correct signal level selection. If terminal A2 is used, check DIP switch S1 parameter H3-08. If terminal A3 is used, check parameter H3-08.
Selection for the sink/source mode and the internal/external power supply is incorrect.	Check jumper S3.
Frequency reference is too low.	<ul style="list-style-type: none"> <li>Check the frequency reference monitor (U1-01).</li> <li>Increase the frequency by changing the maximum output frequency (E1-09).</li> </ul>
Multi-function analog input is set up to accept gain for the frequency reference, but no voltage (current) has been provided.	<ul style="list-style-type: none"> <li>Check the multi-function analog input settings.</li> <li>Check if analog input A1, A2, or A3 is set for frequency reference gain (H3-02, H3-10, H3-06 = 1). If so, check if the correct signal is applied to the terminal. The gain and the frequency reference will be 0 if no signal is applied to the gain input.</li> <li>Check if H3-02, H3-10, and H3-06 have been set to the proper values.</li> <li>Check if the analog input value has been set properly. (U1-13 to U1-15)</li> </ul>



Cause	Possible Solutions
 was pressed when the drive was started from a REMOTE source.	<ul style="list-style-type: none"> <li>Pressing  will decelerate the drive to stop.</li> <li>Switch off the Run command and then re-enter a new Run command.</li> <li>Set o2-02 to 0 to disable .</li> </ul>
Motor starting torque is too low.	<i>Refer to Motor Performance Fine-Tuning on page 174.</i>
Frequency reference value is too low or the drive does not accept the value entered.	Enter a value that is above the minimum output frequency determined by E1-09.
The sequence Start/Stop sequence is set up incorrectly.	<ul style="list-style-type: none"> <li>If the drive is supposed to be set up for a 2-wire sequence, then ensure parameters H1-03 through H1-08 are not set to 0.</li> <li>If the drive is supposed to be set up for a 3-wire sequence, then one of the parameters H1-03 through H1-08 must be set to 0. Terminal S1 will become the Start, terminal S2 will become the Stop input.</li> </ul>

■ Motor Rotates in the Opposite Direction from the Run Command

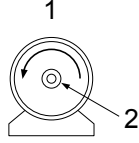
Cause	Possible Solutions
Phase wiring between the drive and motor is incorrect.	<ul style="list-style-type: none"> <li>Check the motor wiring.</li> <li>Switch two motor cables (U, V, and W) to reverse motor direction.</li> <li>Connect drive output terminals U/T1, V/T2, and W/T3 in the right order to match motor terminals U, V, and W.</li> <li>Change the setting of parameter b1-14.</li> </ul>
The forward direction for the motor is set up incorrectly.	Typically, forward is designated as being counterclockwise when looking from the motor shaft (see figure below). <div style="text-align: center;">  </div> <ol style="list-style-type: none"> <li>Forward Rotating Motor (looking down the motor shaft)</li> <li>Motor Shaft</li> </ol>
The motor is running at almost 0 Hz and the Speed Search estimated the speed to be in the opposite direction.	<ul style="list-style-type: none"> <li>Disable bi-directional search (b3-14 = 0) so that Speed Search is performed only in the specified direction.</li> </ul>

**Note:** Check the motor specifications for the forward and reverse directions. The motor specifications will vary depending on the manufacturer of the motor.

■ Motor Rotates in One Direction Only

Cause	Possible Solutions
The drive prohibits reverse rotation.	<ul style="list-style-type: none"> <li>Check parameter b1-04.</li> <li>Set parameter b1-04 to 0 to allow the motor to rotate in reverse.</li> </ul>
A Reverse run signal has not been entered, although 3-Wire sequence is selected.	<ul style="list-style-type: none"> <li>Make sure that one of the input terminals S3 to S8 used for the 3-Wire sequence has been set for reverse.</li> </ul>

◆ Motor is Too Hot

Cause	Possible Solutions
The load is too heavy.	If the load is too heavy for the motor, the motor will overheat as it exceeds its rated torque value for an extended period of time. Keep in mind that the motor also has a short-term overload rating in addition to the possible solutions provided below: <ul style="list-style-type: none"> <li>Reduce the load.</li> <li>Increase the acceleration and deceleration times.</li> <li>Check the values set for the motor protection (L1-01, L1-02) as well as the motor rated current (E2-01).</li> <li>Increase motor capacity.</li> </ul>
The air around the motor is too hot.	<ul style="list-style-type: none"> <li>Check the ambient temperature.</li> <li>Cool the area until it is within the specified temperature range.</li> </ul>

## 2.10 Troubleshooting without Fault Display

Cause	Possible Solutions
The drive is operating in a vector control mode but Auto-Tuning has not yet been performed.	<ul style="list-style-type: none"> <li>Perform Auto-Tuning.</li> <li>Calculate the motor value and reset the motor parameters.</li> <li>Change the motor control method to V/f Control (A1-02 = 0).</li> </ul>
Insufficient voltage insulation between motor phases.	<p>When the motor cable is long, high voltage surges occur between the motor coils and drive switching. Normally, surges can reach up to three times the drive input power supply voltage.</p> <ul style="list-style-type: none"> <li>Use a motor with a voltage tolerance higher than the max voltage surge.</li> <li>Use an inverter-duty motor rated for use with AC drives when using the motor on drives rated higher than 200 V class.</li> <li>Install an AC reactor on the output side of the drive. The carrier frequency should be set to 2 kHz when installing an AC reactor.</li> </ul>
The motor fan has stopped or is clogged.	Check the motor fan.
The carrier frequency is too low.	Increase the carrier frequency to lower the current harmonic distortion and lower the motor temperature.

### ◆ Drive Does Not Allow Selection of the Desired Auto-Tuning Mode

Cause	Possible Solutions
The desired Auto-Tuning mode is not available for the selected control mode.	<ul style="list-style-type: none"> <li>Check if the desired tuning mode is available for the selected control mode.</li> <li>Change the motor control method by setting A1-02.</li> </ul>

### ◆ oPE02 Error Occurs When Lowering the Motor Rated Current Setting

Cause	Possible Solutions
Motor rated current and the motor no-load current setting in the drive are incorrect.	<ul style="list-style-type: none"> <li>The user is trying to set the motor rated current in E2-01 to a value lower than the no-load current set in E2-03.</li> <li>Make sure that value set in E2-01 is higher than E2-03.</li> <li>If it is necessary to set E2-01 lower than E2-03, first lower the value set to E2-03, then change the setting in E2-01 as needed.</li> </ul>

### ◆ Motor Stalls during Acceleration or Acceleration Time is Too Long

Cause	Possible Solutions
Torque limit has been reached or current suppression keeps the drive from accelerating.	Take the following steps to resolve the problem:
Load is too heavy.	<ul style="list-style-type: none"> <li>Reduce the load.</li> <li>Increase motor capacity.</li> </ul> <p><b>Note:</b> Although the drive has a Stall Prevention function and a Torque Compensation Limit function, accelerating too quickly or trying to drive an excessively large load can exceed the capabilities of the motor.</p>
Torque limit is not set properly.	Check the torque limit setting.
Frequency reference is too low.	<ul style="list-style-type: none"> <li>Check the maximum output frequency (E1-04).</li> <li>Increase E1-04 if it is set too low.</li> </ul> <p>Check U1-01 for proper frequency reference.</p> <p>Check if a frequency reference signal switch has been set to one of the multi-function input terminals.</p> <p>Check for low gain level set to terminals A1, A2, or A3 (H3-03, H3-11, H3-07).</p>
Load is too heavy.	<ul style="list-style-type: none"> <li>Reduce the load so that the output current remains within the motor rated current.</li> <li>In extruder and mixer applications, the load will sometimes increase as the temperature drops.</li> <li>Increase the acceleration time.</li> <li>Check if the mechanical brake is fully releasing as it should.</li> </ul>
Acceleration time has been set too long.	Check if the acceleration time parameters have been set too long (C1-01, C1-03, C1-05, C1-07).
Motor characteristics and drive parameter settings are incompatible with one another.	<ul style="list-style-type: none"> <li>Set the correct V/f pattern so that it matches the characteristics of the motor being used.</li> <li>Check the V/f pattern set to E1-03.</li> <li>Execute Rotational Auto-Tuning.</li> </ul>
Although the drive is operating in Open Loop Vector motor control method, Auto-Tuning has not been performed.	<ul style="list-style-type: none"> <li>Perform Auto-Tuning.</li> <li>Calculate motor data and reset motor parameters.</li> <li>Switch to V/f Control (A1-02 = 0).</li> </ul>

Cause	Possible Solutions
Incorrect frequency reference setting.	<ul style="list-style-type: none"> <li>Check the multi-function analog input settings. Multi-function analog input terminal A1, A2, or A3 is set for frequency gain (H3-02, H3-10, or H3-06 is set to "1"), but there is no voltage or current input provided.</li> <li>Make sure H3-02, H3-10, and H3-06 are set to the proper values.</li> <li>See if the analog input value is set to the right value (U1-13 to U1-15).</li> </ul>
The Stall Prevention level during acceleration and deceleration set too low.	<ul style="list-style-type: none"> <li>Check the Stall Prevention level during acceleration (L3-02).</li> <li>If L3-02 is set too low, acceleration may be taking too long.</li> <li>Increase L3-02.</li> </ul>
The Stall Prevention level during run has been set too low.	<ul style="list-style-type: none"> <li>Check the Stall Prevention level during run (L3-06).</li> <li>If L3-06 is set too low, speed will drop as the drive outputs torque.</li> <li>Increase the setting value.</li> </ul>
Drive reached the limitations of the V/f motor control method.	<ul style="list-style-type: none"> <li>The motor cable may be long enough (over 50 m) to require Auto-Tuning for line-to-line resistance.</li> <li>Be aware that V/f Control is comparatively limited when it comes to producing torque at low speeds.</li> <li>Consider switching to Open Loop Vector Control.</li> </ul>

◆ Drive Frequency Reference Differs from the Controller Frequency Reference Command

Cause	Possible Solutions
The analog input gain and bias for the frequency reference input are set to incorrect values.	<ul style="list-style-type: none"> <li>Check the gain and bias settings for the analog inputs that are used to set the frequency reference. Check parameters H3-03 and H3-04 for input A1, check parameters H3-11 and H3-12 for input A2, and check parameters H3-07 and H3-08 for input A3.</li> <li>Set these parameters to the appropriate values.</li> </ul>
A frequency bias signal is being entered via analog input terminals A1 to A3.	<ul style="list-style-type: none"> <li>If more than one of multi-function analog inputs A1 to A3 is set for frequency reference bias (H3-02, H3-10, or H3-06 is set to "0"), then the sum of all signals builds the frequency reference.</li> <li>Make sure that H3-02, H3-10, and H3-06 are set appropriately.</li> <li>Check the input level set for terminals A1 to A3 (U1-13 to U1-15).</li> </ul>
PID control is enabled, and the drive is consequently adjusting the output frequency to match the PID setpoint. The drive will only accelerate to the maximum output frequency set in E1-04 while PID control is active.	If PID control is not necessary for the application, disable it by setting b5-01 to 0.

◆ Excessive Motor Oscillation and Erratic Rotation

Cause	Possible Solutions
Poor balance between motor phases.	Check drive input power voltage to ensure that it provides stable power.
Hunting prevention function is disabled.	<ul style="list-style-type: none"> <li>Enable Hunting Prevention (n1-01 = 1).</li> <li>Increase the AFR gain (n2-01) or the AFR time constant (n2-02).</li> </ul>

◆ Deceleration Takes Longer Than Expected with Dynamic Braking Enabled

Cause	Possible Solutions
L3-04 is set incorrectly.	<ul style="list-style-type: none"> <li>Check the Stall Prevention level during deceleration (L3-04).</li> <li>If a dynamic braking option has been installed, disable Stall Prevention during deceleration (L3-04 = 0).</li> </ul>
The deceleration time is set too long.	Set deceleration to more appropriate time (C1-02, C1-04, C1-06, C1-08).
Insufficient motor torque.	<ul style="list-style-type: none"> <li>Assuming parameter settings are normal and that no overvoltage occurs when there is insufficient torque, it is likely that the demand on the motor has exceeded the motor capacity.</li> <li>Use a larger motor.</li> </ul>

## 2.10 Troubleshooting without Fault Display

Cause	Possible Solutions
Reaching the torque limit.	<ul style="list-style-type: none"> <li>Check the settings for the torque limit (L7-01 through L7-04).</li> <li>If the torque limit is enabled, deceleration might take longer than expected because the drive cannot output more torque than the limit setting. Ensure the torque limit is set to a high enough value.</li> <li>Increase the torque limit setting.</li> </ul>
Load exceeded the internal torque limit determined by the drive rated current.	<ul style="list-style-type: none"> <li>If multi-function analog input terminal A1, A2, or A3 is set to torque limit (H3-02, H3-10, or H3-06 equals 10, 11, 12, or 15), ensure that the analog input levels are set to the correct levels.</li> <li>Ensure H3-02, H3-10, and H3-06 are set to the right levels.</li> <li>Ensure the analog input is set to the correct value (U1-13 to U1-15).</li> </ul>
	Switch to a larger capacity drive.

### ◆ Noise From Drive or Motor Cables When the Drive is Powered On

Cause	Possible Solutions
Relay switching in the drive generates excessive noise.	<ul style="list-style-type: none"> <li>Lower the carrier frequency (C6-02).</li> <li>Install a noise filter on the input side of drive input power.</li> <li>Install a noise filter on the output side of the drive.</li> <li>Place the wiring inside a metal conduit to shield it from switching noise.</li> <li>Ground the drive and motor properly.</li> <li>Separate the main circuit wiring and the control lines.</li> <li>Make sure wires and the motor have been properly grounded.</li> </ul>

### ◆ Ground Fault Circuit Interrupter (GFCI) Trips During Run

Cause	Possible Solutions
Excessive leakage current trips GFCI.	<ul style="list-style-type: none"> <li>Check the wiring and rating of peripheral devices.</li> <li>Increase the GFCI sensitivity or use GFCI with a higher threshold.</li> <li>Lower the carrier frequency (C6-02).</li> <li>Reduce the length of the cable used between the drive and the motor.</li> <li>Install a noise filter or reactor on the output side of the drive. Set the carrier frequency to 2 kHz when connecting a reactor.</li> <li>Disable the internal EMC filter.</li> </ul>

### ◆ Connected Machinery Vibrates When Motor Rotates

#### ■ Unexpected Noise from Connected Machinery

Cause	Possible Solutions
The carrier frequency is at the resonant frequency of the connected machinery.	Adjust the carrier frequency using parameters C6-02 through C6-05.
The drive output frequency is the same as the resonant frequency of the connected machinery.	<ul style="list-style-type: none"> <li>Adjust the parameters used for the Jump frequency function (d3-01 through d3-04) to skip the problem-causing bandwidth.</li> <li>Place the motor on a rubber pad to reduce vibration.</li> </ul>

**Note:** The drive may have trouble assessing the status of the load due to white noise generated from using Swing PWM (C6-02 = 7 to A).

#### ■ Oscillation or Hunting

Cause	Possible Solutions
Insufficient tuning.	Perform Auto-Tuning. <i>Refer to Motor Performance Fine-Tuning on page 174.</i>
Gain is too low when using PID control.	<i>Refer to b5: PID Control on page 33 for details.</i>
The frequency reference is assigned to an external source and the signal is noisy.	<ul style="list-style-type: none"> <li>Ensure that noise is not affecting the signal lines.</li> <li>Separate main circuit wiring and control circuit wiring.</li> <li>Use twisted-pair cables or shielded wiring for the control circuit.</li> <li>Increase the analog input time filter constant (H3-13).</li> </ul>
The cable between the drive and motor is too long.	<ul style="list-style-type: none"> <li>Perform Auto-Tuning.</li> <li>Reduce the length of the cable.</li> </ul>

◆ PID Output Fault

Cause	Possible Solutions
No PID feedback input.	<ul style="list-style-type: none"> <li>Check the multi-function analog input terminal settings.</li> <li>Set multi-function analog input terminal A1, A2, or A3 for PID feedback (H3-02, H3-10, or H3-06 = "B").</li> <li>A signal input to the terminal selection for PID feedback is needed.</li> <li>Check the connection of the feedback signal.</li> <li>Check the various PID-related parameter settings.</li> <li>No PID feedback input to the terminal causes the value detected to be 0, causing a PID fault and the drive to operate at max frequency.</li> </ul>
The level of detection and the target value do not correspond with each other.	<ul style="list-style-type: none"> <li>PID control keeps the difference between target and detection values at 0. Set the input level for the values relative to one another.</li> <li>Use analog input gains H3-03 and H3-11 to adjust PID target and feedback signal scaling.</li> </ul>
Reverse drive output frequency and speed detection. When output frequency rises, the sensor detects a speed decrease.	Set PID output for reverse characteristics (b5-09 = 1).
Adjustment made to PID parameter settings are insufficient.	<i>Refer to b5: PID Control on page 33</i> for details.

◆ Insufficient Starting Torque

Cause	Possible Solutions
Auto-Tuning has not yet been performed (required for vector control modes).	Perform Auto-Tuning. <i>Refer to Motor Performance Fine-Tuning on page 174.</i>
The control mode was changed after performing Auto-Tuning.	Perform Auto-Tuning again.
Only Stationary Auto-Tuning was performed.	Perform Rotational Auto-Tuning.

◆ Motor Rotates After the Drive Output is Shut Off (Motor Rotates During DC Injection Braking)

Cause	Possible Solutions
DC Injection Braking is set too low and the drive cannot decelerate properly.	<ul style="list-style-type: none"> <li>Adjust the DC Injection braking settings.</li> <li>Increase the current level for DC Injection Braking (b2-02).</li> <li>Increase the DC Injection Braking time at stop (b2-04).</li> </ul>
The stopping method is set so that the drive coasts to stop.	Set b1-03 (Stopping Method Selection) to 0 or 2.

◆ Output Frequency is Not as High as Frequency Reference

Cause	Possible Solutions
Frequency reference is set within the range of the Jump frequency.	<ul style="list-style-type: none"> <li>Adjust the parameters used for the Jump frequency function (d3-01, d3-02, d3-03).</li> <li>Enabling the Jump frequency prevents the drive from outputting the frequencies specified in the Jump range.</li> </ul>
Upper limit for the frequency reference has been exceeded.	<ul style="list-style-type: none"> <li>Set the maximum output frequency and the upper limit for the frequency reference to more appropriate values (E1-04, d2-01).</li> <li>The following calculation yields the upper value for the output frequency:  <math display="block">E1-04 \times d2-01 / 100</math> </li> </ul>
Large load triggered Stall Prevention function during acceleration.	<ul style="list-style-type: none"> <li>Reduce the load.</li> <li>Adjust the Stall Prevention level during acceleration (L3-02).</li> </ul>

◆ Sound from Motor

Cause	Possible Solutions
Exceeded 110% of the rated output current of the drive while operating at low speeds.	<ul style="list-style-type: none"> <li>If the output current rises too high at low speeds, the carrier frequency is automatically reduced and causes a whining or buzzing sound.</li> <li>If the sound is coming from the motor, disable carrier frequency derating (L8-38 = 0).</li> <li>Disabling the automatic carrier frequency derating increases the chances of an overload fault (oL2). Switch to a larger capacity motor if oL2 faults occur too frequently.</li> </ul>

### ◆ Motor Does Not Restart after Power Loss

Cause	Possible Solutions
The Run command was not issued again when power was restored.	<ul style="list-style-type: none"><li>• Check the sequence and wiring that has been set up to enter the Run command.</li><li>• A relay should be set up to make sure the Run command remains enabled throughout any power loss.</li></ul>
The relay that is supposed to maintain the Run command has been switched off.	Check wiring and circuitry for the relay intended to keep the Run command enabled.

# Appendix: A

## Parameter List

---

This appendix contains a full listing of all parameters and settings available in the drive.







<b>A.1</b>	<b>UNDERSTANDING PARAMETER DESCRIPTIONS.....</b>	<b>232</b>
<b>A.2</b>	<b>PARAMETER GROUPS.....</b>	<b>233</b>
<b>A.3</b>	<b>A: INITIALIZATION PARAMETERS.....</b>	<b>235</b>
<b>A.4</b>	<b>B: APPLICATION.....</b>	<b>237</b>
<b>A.5</b>	<b>C: TUNING.....</b>	<b>244</b>
<b>A.6</b>	<b>D: REFERENCES.....</b>	<b>250</b>
<b>A.7</b>	<b>E: MOTOR PARAMETERS.....</b>	<b>255</b>
<b>A.8</b>	<b>F: OPTIONS.....</b>	<b>259</b>
<b>A.9</b>	<b>H PARAMETERS: MULTI-FUNCTION TERMINALS.....</b>	<b>267</b>
<b>A.10</b>	<b>L: PROTECTION FUNCTION.....</b>	<b>280</b>
<b>A.11</b>	<b>N: SPECIAL ADJUSTMENT.....</b>	<b>288</b>
<b>A.12</b>	<b>O: OPERATOR-RELATED SETTINGS.....</b>	<b>290</b>
<b>A.13</b>	<b>DRIVEWORKSEZ PARAMETERS.....</b>	<b>293</b>
<b>A.14</b>	<b>T: MOTOR TUNING.....</b>	<b>294</b>
<b>A.15</b>	<b>U: MONITORS.....</b>	<b>296</b>
<b>A.16</b>	<b>CONTROL MODE DEPENDENT PARAMETER DEFAULT VALUES.....</b>	<b>305</b>
<b>A.17</b>	<b>V/F PATTERN DEFAULT VALUES.....</b>	<b>308</b>
<b>A.18</b>	<b>DEFAULTS BY DRIVE MODEL AND DUTY RATING ND/HD.....</b>	<b>309</b>

## A.1 Understanding Parameter Descriptions

### ◆ A1-02 Control Modes, Symbols, and Terms

The table below lists terms and symbols used in this section to indicate which parameters are available in which control modes.

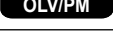
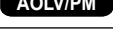
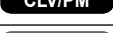
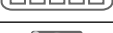
Table A.1 Symbols and Icons Used in Parameter Descriptions

Symbol	Description
	Parameter is available in all control modes.
	Parameter is available when operating the drive with V/f Control.
	Parameter is available when operating the drive with V/f with PG Control.
	Parameter is available when operating the drive with Open Loop Vector.
	Parameter is available when operating the drive with Closed Loop Vector.
	Parameter is available when operating the drive with Open Loop Vector for PM motors. <99>
	Parameter is available when operating the drive with Advanced Open Loop Vector for PM motors. <99>
	Parameter is available when operating the drive with Closed Loop Vector for PM motors. <99>
	Parameter is NOT available when operating the drive in the control mode.
	Parameter can be changed during run.
Motor 2	Refers to a second motor when the drive is operating two motors. Switch between these motors using the multi-function input terminals.

<99>Note: PM motor control modes are not available in A1000 HHP drive models.



## A.2 Parameter Groups

Parameter Group	Name	Page	Parameter Group	Name	Page
A1	Initialization Parameters	<a href="#">235</a>	H1	Multi-Function Digital Inputs	<a href="#">267</a>
A2	User Parameters	<a href="#">236</a>	H2 <1>	Multi-Function Digital Outputs	<a href="#">271</a>
b1	Operation Mode Selection	<a href="#">237</a>	H3 <1>	Multi-Function Analog Inputs	<a href="#">274</a>
b2	DC Injection Braking and Short Circuit Braking	<a href="#">238</a>	H4	Multi-Function Analog Outputs	<a href="#">277</a>
b3 <1>	Speed Search	<a href="#">239</a>	H5	MEMOBUS/Modbus Serial Communication	<a href="#">277</a>
b4	Timer Function	<a href="#">240</a>	H6	Pulse Train Input/Output	<a href="#">278</a>
b5	PID Control	<a href="#">240</a>	L1 <1>	Motor Protection	<a href="#">280</a>
b6	Dwell Function	<a href="#">242</a>	L2	Momentary Power Loss Ride-Thru	<a href="#">281</a>
b7	Droop Control	<a href="#">242</a>	L3 <1>	Stall Prevention	<a href="#">282</a>
b8	Energy Saving		L4	Speed Detection	<a href="#">283</a>
b9	Zero Servo	<a href="#">243</a>	L5	Fault Restart	<a href="#">284</a>
C1	Acceleration and Deceleration Times	<a href="#">244</a>	L6	Torque Detection	<a href="#">284</a>
C2	S-Curve Characteristics	<a href="#">245</a>	L7	Torque Limit	<a href="#">285</a>
C3 <1>	Slip Compensation	<a href="#">245</a>	L8 <1>	Drive Protection	<a href="#">286</a>
C4	Torque Compensation	<a href="#">246</a>	n1	Hunting Prevention	<a href="#">288</a>
C5	Automatic Speed Regulator (ASR)	<a href="#">247</a>	n2	Speed Feedback Detection Control (AFR) Tuning	<a href="#">288</a>
C6 <1>	Carrier Frequency	<a href="#">248</a>	n3	High Slip Braking (HSB) and Overexcitation Braking	<a href="#">288</a>
d2	Frequency Upper/Lower Limits	<a href="#">251</a>	o1	Digital Operator Display Selection	<a href="#">290</a>
d3	Jump Frequency	<a href="#">251</a>	o2	Digital Operator Keypad Functions	<a href="#">290</a>
d4	Frequency Reference Hold and Up/Down 2 Function	<a href="#">252</a>	o3	Copy Function	<a href="#">291</a>
d5	Torque Control	<a href="#">253</a>	o4	Maintenance Monitor Settings	<a href="#">291</a>
d6	Field Weakening and Field Forcing	<a href="#">253</a>	q	DriveWorksEZ Parameters	<a href="#">293</a>
d7	Offset Frequency	<a href="#">254</a>	r	DriveWorksEZ Connection Parameters	<a href="#">293</a>
E1	V/f Pattern for Motor 1	<a href="#">255</a>	T1	Induction Motor Auto-Tuning	<a href="#">294</a>
E3	V/f Pattern for Motor 2	<a href="#">257</a>	T3	ASR and Inertia Tuning	<a href="#">295</a>
E4 <1>	Motor 2 Parameters	<a href="#">258</a>	U1 <1>	Operation Status Monitors	<a href="#">296</a>
F1	PG Speed Control Card (PG-B3/PG-X3)	<a href="#">259</a>	U3	Fault History	<a href="#">300</a>
F2	Analog Input Card (AI-A3)	<a href="#">261</a>	U4 <1>	Maintenance Monitors	<a href="#">300</a>
F3	Digital Input Card (DI-A3)	<a href="#">261</a>	U5	PID Monitors	<a href="#">303</a>
F4	Analog Monitor Card (AO-A3)	<a href="#">262</a>	U6	Operation Status Monitors	<a href="#">303</a>
F5	Digital Output Card (DO-A3)	<a href="#">262</a>	U8	DriveWorksEZ Monitors	<a href="#">304</a>
F6, F7	Communication Option Card	<a href="#">263</a>			

<1> Specifications differ for models CIMR-A□4A0930, 4A1200 and A1000 HHP. [Refer to Parameter Differences for Models CIMR-A□4A0930 and 4A1200 on page 233](#) for details.

### ◆ Parameter Differences for Models CIMR-A□4A0930 and 4A1200

Table A.2 Overview of Parameter Differences by Parameter Group

Parameter Group	Name	Differences
b3	Speed Search	Depends on b3-04 setting. <a href="#">Refer to b3: Speed Search on page 239</a> for details.
C3	Slip Compensation	<ul style="list-style-type: none"> <li>Depends on C3-05 setting. <a href="#">Refer to C3: Slip Compensation on page 245</a> for details.</li> <li>C3-16 to C3-18 are available.</li> </ul>
C6	Carrier Frequency	<ul style="list-style-type: none"> <li>Defaults and setting ranges differ for C6-02, C6-03, and C6-04. <a href="#">Refer to C6: Carrier Frequency on page 248</a> for details.</li> <li>C6-09 is not available.</li> </ul>



## A.2 Parameter Groups

Parameter Group	Name	Differences
E2	Motor 1 Parameters	Setting units differ for E2-05. <i>Refer to E2: Motor 1 Parameters on page 256</i> for details.
E4	Motor 2 Parameters	Setting units differ for E4-05. <i>Refer to E4: Motor 2 Parameters on page 258</i> for details.
H2	Multi-Function Digital Outputs	H2-□□ cannot be set to D, 4E, or 4F.
H3	Multi-Function Digital Inputs	H3-□□ = 17 is available.
L1	Motor Protection	L1-15 to L1-20 are available. <i>Refer to L1: Motor Protection on page 280</i> for details.
L3	Stall Prevention	<i>Refer to L3: Stall Prevention on page 282</i> for details.
L8	Drive Protection	<ul style="list-style-type: none"> <li>L8-01 and L8-55 are not available.</li> <li>L8-78 is available.</li> </ul>
n8	PM Motor Control Timing	n8-84 is available.
U1	Operation Status Monitors	<ul style="list-style-type: none"> <li>Setting units differ for U1-03. <i>Refer to U1: Operation Status Monitors on page 296</i> for details.</li> <li>U1-29 is available.</li> </ul>
U2	Fault Trace	<ul style="list-style-type: none"> <li>Setting units differ for U2-05. <i>Refer to U2: Fault Trace on page 298</i> for details.</li> <li>U2-27 and U2-28 are available.</li> </ul>
U4	Maintenance Monitors	<ul style="list-style-type: none"> <li>Setting units differ for U4-13. <i>Refer to U4: Maintenance Monitors on page 300</i> for details.</li> <li>U4-32, U4-37, U4-38, and U4-39 are available.</li> </ul>

## A.3 A: Initialization Parameters

The A parameter group creates the operating environment for the drive. This includes the parameter Access Level, Motor Control Method, Password, User Parameters and more.

### ◆ A1: Initialization

No. (Addr. Hex)	Name	Description	Values	Page
A1-00 (100)  <>	Language Selection	<b>All Modes</b> 0: English 1: Japanese	Default: 0 Range: 0, 1	10
A1-01 (101)  <>	Access Level Selection	<b>All Modes</b> 0: View and set A1-01 and A1-04. U□-□□ parameters can also be viewed. 1: User Parameters (access to a set of parameters selected by the user, A2-01 to A2-32) 2: Advanced Access (access to view and set all parameters)	Default: 2 Range: 0 to 2	10
A1-02 (102) <>	Control Method Selection	<b>All Modes</b> 0: V/f Control 1: V/f Control with PG 2: Open Loop Vector Control 3: Closed Loop Vector Control	Default: 2 Range: 0 to 3	10
A1-03 (103)	Initialize Parameters	<b>All Modes</b> 0: No initialization 1110: User Initialize (parameter values must be stored using parameter o2-03) 2220: 2-Wire initialization 3330: 3-Wire initialization 5550: oPE04 error reset	Default: 0 Range: 0 to 3330; 5550	11
A1-04 (104)	Password	<b>All Modes</b> When the value set into A1-04 does not match the value set into A1-05, parameters A1-01 through A1-03, A1-06, and A2-01 through A2-33 cannot be changed.	Default: 0000 Min.: 0000 Max.: 9999	11
A1-05 (105)	Password Setting	<b>All Modes</b> When the value set into A1-04 does not match the value set into A1-05, parameters A1-01 through A1-03, A1-06, and A2-01 through A2-33 cannot be changed.	Default: 0000 Min.: 0000 Max.: 9999	11
A1-06 (127)	Application Preset	<b>All Modes</b> 0: General-purpose 1: Water supply pump 2: Conveyor 3: Exhaust fan 4: HVAC fan 5: Air compressor 6: 7:	Default: 0 Range: 0 to 7	14
A1-07 (128)	DriveWorksEZ Function Selection	<b>All Modes</b> 0: DWEZ Disabled 1: DWEZ Enabled 2: Digital input (enabled when H1-□□ = 9F)	Default: 0 Range: 0 to 2	16

<1> Parameter setting value is not reset to the default value when the drive is initialized.

<2> Default setting value is dependent on the Application Preset selected with parameter A1-06.

## A.3 A: Initialization Parameters

### ◆ A2: User Parameters

No. (Addr. Hex)	Name	Description	Values	Page
A2-01 to A2-32 (106 to 125)	User Parameters 1 to 32	<p><b>All Modes</b></p> <p>Recently edited parameters are listed here. The user can also select parameters to appear here for quicker access.</p>	<p>Default: &lt;1&gt;</p> <p>Range: b1-01 to o4-13</p>	17
A2-33 (126)	User Parameter Automatic Selection	<p><b>All Modes</b></p> <p>0: Parameters A2-01 to A2-32 are reserved for the user to create a list of User Parameters.            1: Save history of recently viewed parameters. Recently edited parameters will be saved to A2-17 through A2-32 for quicker access.</p>	<p>Default: 1 &lt;2&gt;</p> <p>Range: 0, 1</p>	17

<1> Default setting value is dependent on the Application Preset selected with parameter A1-06.

<2> Default setting value is dependent on parameter A1-06. Default is 0 when A1-06 = 0, and 1 when A1-06 ≠ 0.

## A.4 b: Application

Application parameters configure the source of the Run command, DC Injection Braking, Speed Search, timer functions, PID control, the Dwell function, Energy Savings, and a variety of other application-related settings.

### ◆ b1: Operation Mode Selection

No. (Addr. Hex)	Name	Description	Values	Page
b1-01 (180)	Frequency Reference Selection 1	<b>All Modes</b> 0: Digital operator 1: Analog input terminals 2: MEMOBUS/Modbus communications 3: Option PCB 4: Pulse input (terminal RP)	Default: 1 Range: 0 to 4	18
b1-02 (181)	Run Command Selection 1	<b>All Modes</b> 0: Digital operator 1: Digital input terminals 2: MEMOBUS/Modbus communications 3: Option PCB	Default: 1 Range: 0 to 3	19
b1-03 (182)	Stopping Method Selection	<b>All Modes</b> 0: Ramp to stop 1: Coast to stop 2: DC Injection Braking to stop 3: Coast with timer	Default: 0 Range: 0 to 3 <1>	20
b1-04 (183)	Reverse Operation Selection	<b>All Modes</b> 0: Reverse enabled. 1: Reverse disabled.	Default: 0 Range: 0, 1	22
b1-05 (184)	Action Selection below Minimum Output Frequency	<div style="display: flex; justify-content: space-between; align-items: center;"> <span>V/f</span> <span>V/f w PG</span> <span>OLV</span> <span style="background-color: black; color: white; padding: 2px;">CLV</span> </div> <div style="display: flex; justify-content: space-between; align-items: center; margin-top: 5px;"> <span>OLV/PM</span> <span>AOLV/PM</span> <span style="background-color: black; color: white; padding: 2px;">CLV/PM</span> </div> 0: Operates according to frequency reference (E1-09 is disabled). 1: Output shuts off (coast to stop if less than E1-09). 2: Operates according to E1-09 (frequency reference set to E1-09). 3: Zero speed (frequency reference becomes zero when less than E1-09).	Default: 0 Range: 0 to 3	22
b1-06 (185)	Digital Input Reading	<b>All Modes</b> 0: Input status is read once and processed immediately (for quicker response) 1: Input is read twice and processed only if the status is the same in both readings (robust against noisy signals)	Default: 1 Range: 0, 1	23
b1-07 (186)	LOCAL/REMOTE Run Selection	<b>All Modes</b> 0: An external Run command must be cycled at the new source in order to be activated. 1: An external Run command at the new source is accepted immediately.	Default: 0 Range: 0, 1	24
b1-08 (187)	Run Command Selection in Programming Mode	<b>All Modes</b> 0: Run command is not accepted while in Programming Mode. 1: Run command is accepted while in Programming Mode. 2: Prohibit entering Programming Mode during run.	Default: 0 Range: 0 to 2	24
b1-14 (1C3)	Phase Order Selection	<div style="display: flex; justify-content: space-between; align-items: center;"> <span style="background-color: black; color: white; padding: 2px;">V/f</span> <span>V/f w PG</span> <span>OLV</span> <span style="background-color: black; color: white; padding: 2px;">CLV</span> </div> <div style="display: flex; justify-content: space-between; align-items: center; margin-top: 5px;"> <span style="background-color: black; color: white; padding: 2px;">OLV/PM</span> <span>AOLV/PM</span> <span>CLV/PM</span> </div> 0: Standard 1: Switch phase order (reverses the direction of the motor)	Default: 0 Range: 0, 1	24
b1-15 (1C4)	Frequency Reference Selection 2	<b>All Modes</b> Enabled when an input terminal set for “External reference” (H1-□□ = 2) closes. 0: Digital operator 1: Terminals (analog input terminals) 2: MEMOBUS/Modbus communications 3: Option card 4: Pulse train input	Default: 0 Range: 0 to 4	24

## A.4 b: Application

No. (Addr. Hex)	Name	Description	Values	Page
b1-16 (1C5)	Run Command Selection 2	<b>All Modes</b> Enabled when a terminal set for “External reference” (H1-□□ = 2) closes. 0: Digital operator 1: Digital input terminals 2: MEMOBUS/Modbus communications 3: Option card	Default: 0 Range: 0 to 3	25
b1-17 (1C6)	Run Command at Power Up	<b>All Modes</b> 0: Disregarded. A new Run command must be issued after power up. 1: Allowed. Motor will start immediately after power up if a Run command is already enabled.	Default: 0 Range: 0, 1	25

<1> Settings 2 and 3 are not available in CLV.

## ◆ b2: DC Injection Braking and Short Circuit Braking

No. (Addr. Hex)	Name	Description	Values	Page
b2-01 (189)	DC Injection Braking Start Frequency	<b>All Modes</b> Sets the frequency at which DC Injection Braking starts when “Ramp to stop” (b1-03 = 0) is selected.	Default: <f> Min.: 0.0 Hz Max.: 10.0 Hz	25
b2-02 (18A)	DC Injection Braking Current	V/f   V/f w PG   OLV   CLV OLV/PM   AOLV/PM   CLV/PM Sets the DC Injection Braking current as a percentage of the drive rated current.	Default: 50% Min.: 0 Max.: 100	26
b2-03 (18B)	DC Injection Braking Time at Start	V/f   V/f w PG   OLV   CLV OLV/PM   AOLV/PM   CLV/PM Sets DC Injection Braking (Zero Speed Control when in CLV and CLV/PM) time at start. Disabled when set to 0.00 seconds.	Default: 0.00 s Min.: 0.00 Max.: 10.00	26
b2-04 (18C)	DC Injection Braking Time at Stop	V/f   V/f w PG   OLV   CLV OLV/PM   AOLV/PM   CLV/PM Sets DC Injection Braking (Zero Speed Control when in CLV and CLV/PM) time at stop.	Default: <f> Min.: 0.00 s Max.: 10.00 s	26
b2-08 (190)	Magnetic Flux Compensation Value	V/f   V/f w PG   OLV   CLV OLV/PM   AOLV/PM   CLV/PM Sets the magnetic flux compensation as a percentage of the no-load current value (E2-03).	Default: 0% Min.: 0 Max.: 1000	27

<1> Default setting is determined by parameter A1-02, Control Method Selection.

◆ b3: Speed Search

No. (Addr Hex.)	Name	Description	Values	Page
b3-01 (191)	Speed Search Selection at Start	<p><input checked="" type="radio"/> V/f <input checked="" type="radio"/> V/f w PG <input checked="" type="radio"/> OLV <input type="radio"/> CLV</p> <p><input type="radio"/> OLV/PM <input type="radio"/> AOLV/PM <input type="radio"/> CLV/PM</p> <p>0: Disabled 1: Enabled</p>	Default: </> Range: 0, 1	30
b3-02 (192)	Speed Search Deactivation Current	<p><input checked="" type="radio"/> V/f <input type="radio"/> V/f w PG <input checked="" type="radio"/> OLV <input type="radio"/> CLV</p> <p><input type="radio"/> OLV/PM <input type="radio"/> AOLV/PM <input type="radio"/> CLV/PM</p> <p>Sets the current level at which the speed is assumed to be detected and Speed Search is ended. Set as a percentage of the drive rated current.</p>	Default: </> Min.: 0% Max.: 200%	30
b3-03 (193)	Speed Search Deceleration Time	<p><input checked="" type="radio"/> V/f <input type="radio"/> V/f w PG <input checked="" type="radio"/> OLV <input type="radio"/> CLV</p> <p><input type="radio"/> OLV/PM <input type="radio"/> AOLV/PM <input type="radio"/> CLV/PM</p> <p>Sets output frequency reduction time during Speed Search.</p>	Default: 2.0 s Min.: 0.1 Max.: 10.0	31
b3-04 (194)	V/f Gain during Speed Search	<p><input checked="" type="radio"/> V/f <input checked="" type="radio"/> V/f w PG <input type="radio"/> OLV <input type="radio"/> CLV</p> <p><input type="radio"/> OLV/PM <input type="radio"/> AOLV/PM <input type="radio"/> CLV/PM</p> <p>Determines how much to lower the V/f ratio during Speed Search. Output voltage during Speed Search equals the V/f setting multiplied by b3-04.</p> <p><b>Note:</b> Available control mode for parameter b3-04 varies by drive model: CIMR-A□2A0004 to 2A0415, 4A0002 to 4A0675, and 5A0003 to 5A0242: Available when A1-02 = 0, 1 CIMR-A□4A0930 and 4A1200: Available when A1-02 = 0</p>	Default: <> Min.: 10% Max.: 100%	31
b3-05 (195)	Speed Search Delay Time	<p><b>All Modes</b></p> <p>When using an external contactor on the output side, b3-05 delays executing Speed Search after a momentary power loss to allow time for the contactor to close.</p>	Default: 0.2 s Min.: 0.0 Max.: 100.0	31
b3-06 (196)	Output Current 1 during Speed Search	<p><input checked="" type="radio"/> V/f <input checked="" type="radio"/> V/f w PG <input checked="" type="radio"/> OLV <input type="radio"/> CLV</p> <p><input type="radio"/> OLV/PM <input type="radio"/> AOLV/PM <input type="radio"/> CLV/PM</p> <p>Sets the current injected to the motor at the beginning of Speed Estimation Speed Search. Set as a coefficient for the motor rated current.</p>	Default: <> Min.: 0.0 Max.: 2.0	31
b3-10 (19A)	Speed Search Detection Compensation Gain	<p><input checked="" type="radio"/> V/f <input type="radio"/> V/f w PG <input checked="" type="radio"/> OLV <input type="radio"/> CLV</p> <p><input type="radio"/> OLV/PM <input type="radio"/> AOLV/PM <input type="radio"/> CLV/PM</p> <p>Sets the gain which is applied to the speed detected by Speed Estimation Speed Search before the motor is reaccelerated. Increase this setting if ov occurs when performing Speed Search after a relatively long period of baseblock.</p>	Default: 1.05 Min.: 1.00 Max.: 1.20	31
b3-14 (19E)	Bi-Directional Speed Search Selection	<p><input checked="" type="radio"/> V/f <input checked="" type="radio"/> V/f w PG <input checked="" type="radio"/> OLV <input type="radio"/> CLV</p> <p><input type="radio"/> OLV/PM <input type="radio"/> AOLV/PM <input type="radio"/> CLV/PM</p> <p>0: Disabled (uses the direction of the frequency reference) 1: Enabled (drive detects which way the motor is rotating)</p>	Default: </> Range: 0, 1	31
b3-17 (1F0)	Speed Search Restart Current Level	<p><input checked="" type="radio"/> V/f <input type="radio"/> V/f w PG <input checked="" type="radio"/> OLV <input type="radio"/> CLV</p> <p><input type="radio"/> OLV/PM <input type="radio"/> AOLV/PM <input type="radio"/> CLV/PM</p> <p>Sets the Speed Search restart current level as a percentage of the drive rated current.</p>	Default: 150% Min.: 0 Max.: 200	32
b3-18 (1F1)	Speed Search Restart Detection Time	<p><input checked="" type="radio"/> V/f <input type="radio"/> V/f w PG <input checked="" type="radio"/> OLV <input type="radio"/> CLV</p> <p><input type="radio"/> OLV/PM <input type="radio"/> AOLV/PM <input type="radio"/> CLV/PM</p> <p>Sets the time to detect Speed Search restart.</p>	Default: 0.10 s Min.: 0.00 Max.: 1.00	32
b3-19 (1F2)	Number of Speed Search Restarts	<p><input checked="" type="radio"/> V/f <input type="radio"/> V/f w PG <input checked="" type="radio"/> OLV <input type="radio"/> CLV</p> <p><input type="radio"/> OLV/PM <input checked="" type="radio"/> AOLV/PM <input type="radio"/> CLV/PM</p> <p>Sets the number of times the drive can attempt to restart when performing Speed Search.</p>	Default: 3 Min.: 0 Max.: 10	32
b3-24 (1C0)	Speed Search Method Selection	<p><input checked="" type="radio"/> V/f <input checked="" type="radio"/> V/f w PG <input checked="" type="radio"/> OLV <input type="radio"/> CLV</p> <p><input type="radio"/> OLV/PM <input type="radio"/> AOLV/PM <input type="radio"/> CLV/PM</p> <p>0: Current Detection 1: Speed Estimation</p>	Default: 0 Range: 0, 1	32

## A.4 b: Application

No. (Addr. Hex.)	Name	Description	Values	Page
b3-25 (1C8)	Speed Search Wait Time	<div style="display: flex; justify-content: space-around; align-items: center;"> <span>V/f</span> <span>V/f w PG</span> <span>OLV</span> <span>CLV</span> </div> <div style="display: flex; justify-content: space-around; align-items: center;"> <span>OLV/PM</span> <span>AOLV/PM</span> <span>CLV/PM</span> </div> <p>Sets the time the drive must wait between each Speed Search restart attempt.</p>	Default: 0.5 s Min.: 0.0 Max.: 30.0	<a href="#">32</a>







<1> Default setting is determined by parameter A1-02, Control Method Selection.

<2> Default setting is dependent on parameter o2-04, Drive Model Selection.



### ◆ b4: Timer Function

No. (Addr. Hex.)	Name	Description	Values	Page
b4-01 (1A3)	Timer Function On-Delay Time	<p><b>All Modes</b></p> <p>Sets the on-delay and off-delay times for a digital timer output (H2-□□=12).</p>	Default: 0.0 s Min.: 0.0 Max.: 3000.0	<a href="#">32</a>
b4-02 (1A4)	Timer Function Off-Delay Time	<p>The output is triggered by a digital input programmed to H1-□□=18).</p>	Default: 0.0 s Min.: 0.0 Max.: 3000.0	<a href="#">32</a>

### ◆ b5: PID Control

No. (Addr. Hex.)	Name	Description	Values	Page
b5-01 (1A5)	PID Function Setting	<p><b>All Modes</b></p> <p>0: Disabled 1: Enabled (PID output becomes output frequency reference, deviation D controlled) 2: Enabled (PID output becomes output frequency reference, feedback D controlled) 3: Enabled (PID output added to frequency reference, deviation D controlled) 4: Enabled (PID output added to frequency reference, feedback D controlled)</p>	Default: 0 Range: 0 to 4	<a href="#">36</a>
b5-02 (1A6) 	Proportional Gain Setting (P)	<p><b>All Modes</b></p> <p>Sets the proportional gain of the PID controller.</p>	Default: 1.00 Min.: 0.00 Max.: 25.00	<a href="#">36</a>
b5-03 (1A7) 	Integral Time Setting (I)	<p><b>All Modes</b></p> <p>Sets the integral time for the PID controller.</p>	Default: 1.0 s Min.: 0.0 Max.: 360.0	<a href="#">36</a>
b5-04 (1A8) 	Integral Limit Setting	<p><b>All Modes</b></p> <p>Sets the maximum output possible from the integrator as a percentage of the maximum output frequency.</p>	Default: 100.0% Min.: 0.0 Max.: 100.0	<a href="#">36</a>
b5-05 (1A9) 	Derivative Time (D)	<p><b>All Modes</b></p> <p>Sets D control derivative time.</p>	Default: 0.00 s Min.: 0.00 Max.: 10.00	<a href="#">36</a>
b5-06 (1AA) 	PID Output Limit	<p><b>All Modes</b></p> <p>Sets the maximum output possible from the entire PID controller as a percentage of the maximum output frequency.</p>	Default: 100.0% Min.: 0.0 Max.: 100.0	<a href="#">36</a>
b5-07 (1AB) 	PID Offset Adjustment	<p><b>All Modes</b></p> <p>Applies an offset to the PID controller output. Set as a percentage of the maximum output frequency.</p>	Default: 0.0% Min.: -100.0 Max.: 100.0	<a href="#">36</a>
b5-08 (1AC) 	PID Primary Delay Time Constant	<p><b>All Modes</b></p> <p>Sets a low pass filter time constant on the output of the PID controller.</p>	Default: 0.00 s Min.: 0.00 Max.: 10.00	<a href="#">37</a>
b5-09 (1AD)	PID Output Level Selection	<p><b>All Modes</b></p> <p>0: Normal output (direct acting) 1: Reverse output (reverse acting)</p>	Default: 0 Range: 0, 1	<a href="#">37</a>
b5-10 (1AE)	PID Output Gain Setting	<p><b>All Modes</b></p> <p>Sets the gain applied to the PID output.</p>	Default: 1.00 Min.: 0.00 Max.: 25.00	<a href="#">37</a>



No. (Addr. Hex)	Name	Description	Values	Page
b5-11 (1AF)	PID Output Reverse Selection	<p><b>All Modes</b></p> <p>0: Negative PID output triggers zero limit. 1: Rotation direction reverses with negative PID output.</p> <p><b>Note:</b> When using setting 1, make sure reverse operation is permitted by b1-04.</p>	Default: 0 Range: 0, 1	37
b5-12 (1B0)	PID Feedback Loss Detection Selection	<p><b>All Modes</b></p> <p>0: No fault. Digital output only. 1: Fault detection. Alarm output, drive continues operation. 2: Fault detection. Fault output, drive output is shut off. 3: No fault. Digital output only. No fault detection when PID control is disabled. 4: Fault detection. Alarm is triggered and drive continues to run. Fault detection even when PID is disabled. 5: Fault detection. Drive output shuts off. No fault detection when PID control is disabled.</p>	Default: 0 Range: 0 to 5	38
b5-13 (1B1)	PID Feedback Loss Detection Level	<p><b>All Modes</b></p> <p>Sets the PID feedback loss detection level as a percentage of the maximum output frequency.</p>	Default: 0% Min.: 0 Max.: 100	38
b5-14 (1B2)	PID Feedback Loss Detection Time	<p><b>All Modes</b></p> <p>Sets a delay time for PID feedback loss.</p>	Default: 1.0 s Min.: 0.0 Max.: 25.5	38
b5-15 (1B3)	PID Sleep Function Start Level	<p><b>All Modes</b></p> <p>Sets the frequency level that triggers the sleep function.</p>	Default: <I> Min.: 0.0 Hz Max.: 400.0 Hz	39
b5-16 (1B4)	PID Sleep Delay Time	<p><b>All Modes</b></p> <p>Sets a delay time before the sleep function is triggered.</p>	Default: 0.0 s Min.: 0.0 Max.: 25.5	39
b5-17 (1B5)	PID Accel/Decel Time	<p><b>All Modes</b></p> <p>Sets the acceleration and deceleration time to PID setpoint.</p>	Default: 0.0 s Min.: 0.0 Max.: 6000.0	39
b5-18 (1DC)	PID Setpoint Selection	<p><b>All Modes</b></p> <p>0: Disabled 1: Enabled</p>	Default: 0 Range: 0, 1	40
b5-19 (1DD)	PID Setpoint Value	<p><b>All Modes</b></p> <p>Sets the PID target value when b5-18 = 1. Set as a percentage of the maximum output frequency.</p>	Default: 0.00% Min.: 0.00 Max.: 100.00	40
b5-20 (1E2)	PID Setpoint Scaling	<p><b>All Modes</b></p> <p>0: 0.01 Hz units 1: 0.01% units (100% = max output frequency) 2: r/min (number of motor poles must entered) 3: User-set (set scaling to b5-38 and b5-39)</p>	Default: 1 Range: 0 to 3	40
b5-34 (19F) 	PID Output Lower Limit	<p><b>All Modes</b></p> <p>Sets the minimum output possible from the PID controller as a percentage of the maximum output frequency.</p>	Default: 0.00% Min.: -100.00 Max.: 100.00	40
b5-35 (1A0) 	PID Input Limit	<p><b>All Modes</b></p> <p>Limits the PID control input (deviation signal) as a percentage of the maximum output frequency. Acts as a bipolar limit.</p>	Default: 1000.0% Min.: 0.0 Max.: 1000.0	40
b5-36 (1A1)	PID Feedback High Detection Level	<p><b>All Modes</b></p> <p>Sets the PID feedback high detection level as a percentage of the maximum output frequency.</p>	Default: 100% Min.: 0 Max.: 100	39
b5-37 (1A2)	PID Feedback High Detection Time	<p><b>All Modes</b></p> <p>Sets the PID feedback high level detection delay time.</p>	Default: 1.0 s Min.: 0.0 Max.: 25.5	39
b5-38 (1FE)	PID Setpoint User Display	<p><b>All Modes</b></p> <p>Sets the display value of U5-01 and U5-04 when the maximum frequency is output.</p>	Default: <2> Min.: 1 Max.: 60000	40

## A.4 b: Application

No. (Addr. Hex)	Name	Description	Values	Page
b5-39 (1FF)	PID Setpoint Display Digits	<b>All Modes</b> 0: No decimal places 1: One decimal place 2: Two decimal places 3: Three decimal places	Default: <2> Range: 0 to 3	40
b5-40 (17F)	Frequency Reference Monitor Content during PID	<b>All Modes</b> 0: Display the frequency reference (U1-01) after PID compensation has been added. 1: Display the frequency reference (U1-01) before PID compensation has been added.	Default: 0 Range: 0, 1	41



<1> Default setting is determined by parameter A1-02, Control Method Selection.

<2> Default setting is dependent on parameter b5-20, PID Setpoint Scaling.

### ◆ b6: Dwell Function

No. (Addr. Hex)	Name	Description	Values	Page
b6-01 (1B6)	Dwell Reference at Start	<b>All Modes</b> Parameters b6-01 and b6-02 set the frequency to hold and the time to maintain that frequency at start.	Default: 0.0 Hz Min.: 0.0 Max.: 400.0	43
b6-02 (1B7)	Dwell Time at Start		Default: 0.0 s Min.: 0.0 Max.: 10.0	43
b6-03 (1B8)	Dwell Reference at Stop	<b>All Modes</b> Parameters b6-03 and b6-04 set the frequency to hold and the time to maintain that frequency at stop.	Default: 0.0 Hz Min.: 0.0 Max.: 400.0	43
b6-04 (1B9)	Dwell Time at Stop		Default: 0.0 s Min.: 0.0 Max.: 10.0	43

### ◆ b7: Droop Control

No. (Addr. Hex)	Name	Description	Values	Page
b7-01 (1CA) 	Droop Control Gain	<div style="display: flex; justify-content: space-between; align-items: center;"> <span>V/f</span> <span>V/f w PG</span> <span>OLV</span> <span><b>CLV</b></span> </div> <div style="display: flex; justify-content: space-between; align-items: center;"> <span>OLV/PM</span> <span>AOLV/PM</span> <span><b>CLV/PM</b></span> </div> Sets the speed reduction gain applied at a torque reference of 100%. Set as a percentage of motor base speed.	Default: 0.0% Min.: 0.0 Max.: 100.0	43
b7-02 (1CB) 	Droop Control Delay Time	<div style="display: flex; justify-content: space-between; align-items: center;"> <span>V/f</span> <span>V/f w PG</span> <span>OLV</span> <span><b>CLV</b></span> </div> <div style="display: flex; justify-content: space-between; align-items: center;"> <span>OLV/PM</span> <span>AOLV/PM</span> <span><b>CLV/PM</b></span> </div> Adjusts the responsiveness of Droop Control.	Default: 0.05 s Min.: 0.03 Max.: 2.00	44
b7-03 (17E)	Droop Control Limit Selection	<div style="display: flex; justify-content: space-between; align-items: center;"> <span>V/f</span> <span>V/f w PG</span> <span>OLV</span> <span><b>CLV</b></span> </div> <div style="display: flex; justify-content: space-between; align-items: center;"> <span>OLV/PM</span> <span>AOLV/PM</span> <span><b>CLV/PM</b></span> </div> 0: Disabled 1: Enabled	Default: 1 Range: 0, 1	44









◆ b9: Zero Servo

No. (Addr. Hex)	Name	Description	Values	Page
b9-01 (1DA)	Zero Servo Gain	<input type="radio"/> V/f <input type="radio"/> V/f w PG <input type="radio"/> OLV <input checked="" type="radio"/> CLV <input type="radio"/> OLV/PM <input type="radio"/> AOLV/PM <input checked="" type="radio"/> CLV/PM Sets the position loop gain for the Zero Servo function.	Default: 5 Min.: 0 Max.: 100	45
b9-02 (1DB)	Zero Servo Completion Width	<input type="radio"/> V/f <input type="radio"/> V/f w PG <input type="radio"/> OLV <input checked="" type="radio"/> CLV <input type="radio"/> OLV/PM <input type="radio"/> AOLV/PM <input checked="" type="radio"/> CLV/PM Sets the range to trigger an output terminal set for “Zero Servo Complete” during Zero Servo operation.	Default: 10 Min.: 0 Max.: 16383	45

## A.5 C: Tuning

C parameters are used to adjust the acceleration and deceleration times, S-curves, slip compensation, torque compensation, and carrier frequency selections.

### ◆ C1: Acceleration and Deceleration Times

No. (Addr. Hex)	Name	Description	Values	Page
C1-01 (200) 	Acceleration Time 1	<b>All Modes</b> Sets the time to accelerate from 0 to maximum frequency.	Default: 10.0 s Min.: 0.0 Max.: 6000.0 <1>	46
C1-02 (201) 	Deceleration Time 1	<b>All Modes</b> Sets the time to decelerate from maximum frequency to 0.	Default: 10.0 s Min.: 0.0 Max.: 6000.0 <1>	46
C1-03 (202) 	Acceleration Time 2	<b>All Modes</b> Sets the time to accelerate from 0 to maximum frequency.	Default: 10.0 s Min.: 0.0 Max.: 6000.0 <1>	46
C1-04 (203) 	Deceleration Time 2	<b>All Modes</b> Sets the time to decelerate from maximum frequency to 0.	Default: 10.0 s Min.: 0.0 Max.: 6000.0 <1>	46
C1-05 (204) 	Acceleration Time 3 (Motor 2 Accel Time 1)	<b>All Modes</b> Sets the time to accelerate from 0 to maximum frequency.	Default: 10.0 s Min.: 0.0 Max.: 6000.0 <1>	46
C1-06 (205) 	Deceleration Time 3 (Motor 2 Decel Time 1)	<b>All Modes</b> Sets the time to decelerate from maximum frequency to 0.	Default: 10.0 s Min.: 0.0 Max.: 6000.0 <1>	46
C1-07 (206) 	Acceleration Time 4 (Motor 2 Accel Time 2)	<b>All Modes</b> Sets the time to accelerate from 0 to maximum frequency.	Default: 10.0 s Min.: 0.0 Max.: 6000.0 <1>	46
C1-08 (207) 	Deceleration Time 4 (Motor 2 Decel Time 2)	<b>All Modes</b> Sets the time to decelerate from maximum frequency to 0.	Default: 10.0 s Min.: 0.0 Max.: 6000.0 <1>	46
C1-09 (208)	Fast Stop Time	<b>All Modes</b> Sets the time for the Fast Stop function.	Default: 10.0 s Min.: 0.0 Max.: 6000.0 <1>	47
C1-10 (209)	Accel/Decel Time Setting Units	<b>All Modes</b> 0: 0.01 s (0.00 to 600.00 s) 1: 0.1 s (0.0 to 6000.0 s)	Default: 1 Range: 0, 1	48
C1-11 (20A)	Accel/Decel Time Switching Frequency	<b>All Modes</b> Sets the frequency to switch between accel/decel time settings	Default: 0.0 Hz Min.: 0.0 Max.: 400.0	47

<1> Setting range value is dependent on parameter C1-10, Accel/Decel Time Setting Units. When C1-10 = 0 (units of 0.01 seconds), the setting range becomes 0.00 to 600.00 seconds.

## ◆ C2: S-Curve Characteristics

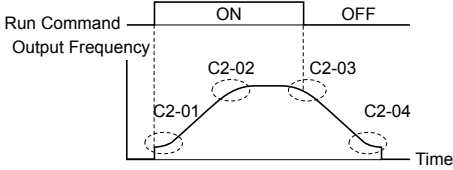

No. (Addr. Hex)	Name	Description	Values	Page
C2-01 (20B)	S-Curve Characteristic at Accel Start	<b>All Modes</b> The S-curve can be controlled at the four points shown below. 	Default: 0.20 s <1> Min.: 0.00 Max.: 10.00	48
C2-02 (20C)	S-Curve Characteristic at Accel End		Default: 0.20 s Min.: 0.00 Max.: 10.00	48
C2-03 (20D)	S-Curve Characteristic at Decel Start		Default: 0.20 s Min.: 0.00 Max.: 10.00	48
C2-04 (20E)	S-Curve Characteristic at Decel End		Default: 0.00 s Min.: 0.00 Max.: 10.00	48

<1> Default setting is determined by parameter A1-02, Control Method Selection.

## ◆ C3: Slip Compensation

No. (Addr. Hex)	Name	Description	Values	Page
C3-01 (20F) RUN	Slip Compensation Gain	<input checked="" type="radio"/> V/f <input type="radio"/> V/f w PG <input checked="" type="radio"/> OLV <input checked="" type="radio"/> CLV <input type="radio"/> OLV/PM <input type="radio"/> AOLV/PM <input type="radio"/> CLV/PM Sets the gain for the motor slip compensation function used for motor 1.	Default: <1> Min.: 0.0 Max.: 2.5	48
C3-02 (210) RUN	Slip Compensation Primary Delay Time	<input checked="" type="radio"/> V/f <input type="radio"/> V/f w PG <input checked="" type="radio"/> OLV <input type="radio"/> CLV <input type="radio"/> OLV/PM <input type="radio"/> AOLV/PM <input type="radio"/> CLV/PM Adjusts the slip compensation function delay time used for motor 1.	Default: <1> Min.: 0 ms Max.: 10000 ms	49
C3-03 (211)	Slip Compensation Limit	<input checked="" type="radio"/> V/f <input type="radio"/> V/f w PG <input checked="" type="radio"/> OLV <input type="radio"/> CLV <input type="radio"/> OLV/PM <input type="radio"/> AOLV/PM <input type="radio"/> CLV/PM Sets an upper limit for the slip compensation function as a percentage of motor rated slip for motor 1 (E2-02).	Default: 200% Min.: 0 Max.: 250	49
C3-04 (212)	Slip Compensation Selection during Regeneration	<input checked="" type="radio"/> V/f <input type="radio"/> V/f w PG <input checked="" type="radio"/> OLV <input type="radio"/> CLV <input type="radio"/> OLV/PM <input type="radio"/> AOLV/PM <input type="radio"/> CLV/PM 0: Disabled. 1: Enabled above 6 Hz. 2: Enabled whenever slip compensation is possible.	Default: 0 Range: 0 to 2	49
C3-05 (213)	Output Voltage Limit Operation Selection	<input type="radio"/> V/f <input type="radio"/> V/f w PG <input checked="" type="radio"/> OLV <input checked="" type="radio"/> CLV <input type="radio"/> OLV/PM <input type="radio"/> AOLV/PM <input type="radio"/> CLV/PM 0: Disabled. 1: Enabled. Automatically decreases motor flux when output voltage saturation is reached. <b>Note:</b> Available control mode for parameter C3-05 varies by drive model: CIMR-A□2A0004 to 2A0415, 4A0002 to 4A0675, and 5A0003 to 5A0242: Available when A1-02 = 0,1. CIMR-A□4A0930 and 4A1200: Available when A1-02 = 2, 3, 6, 7.	Default: 0 Range: 0, 1	50
C3-16 (261)	Output Voltage Limit Operation Start Level (Percentage Modulation)	<input type="radio"/> V/f <input type="radio"/> V/f w PG <input checked="" type="radio"/> OLV <input checked="" type="radio"/> CLV <input type="radio"/> OLV/PM <input type="radio"/> AOLV/PM <input type="radio"/> CLV/PM Sets the output voltage limit operation start level (percentage modulation) when C3-05 is enabled. <b>Note:</b> This parameter is only available in models CIMR-A□4A0930 and 4A1200.	Default: 85.0% Min.: 70.0 Max.: 90.0	50



## A.5 C: Tuning

No. (Addr. Hex)	Name	Description	Values	Page
C3-17 (262)	Maximum Output Voltage Limit Level (Percentage Modulation)	<input type="radio"/> V/f <input type="radio"/> V/f w PG <input checked="" type="radio"/> OLV <input checked="" type="radio"/> CLV <input type="radio"/> OLV/PM <input type="radio"/> AOLV/PM <input type="radio"/> CLV/PM Sets the output voltage limit operation determined by C3-18 (percentage modulation) when C3-05 is enabled. <b>Note:</b> This parameter is only available in models CIMR-A□4A0930 and 4A1200.	Default: 90.0% Min.: 85.0 Max.: 100.0	50
C3-18 (263)	Output Voltage Limit Level	<input type="radio"/> V/f <input type="radio"/> V/f w PG <input checked="" type="radio"/> OLV <input checked="" type="radio"/> CLV <input type="radio"/> OLV/PM <input type="radio"/> AOLV/PM <input type="radio"/> CLV/PM Sets the maximum percentage of output voltage reduction when C3-05 is enabled. <b>Note:</b> This parameter is only available in models CIMR-A□4A0930 and 4A1200.	Default: 90.0% Min.: 30.0 Max.: 100.0	50
C3-21 (33E) 	Motor 2 Slip Compensation Gain	<input checked="" type="radio"/> V/f <input type="radio"/> V/f w PG <input checked="" type="radio"/> OLV <input checked="" type="radio"/> CLV <input type="radio"/> OLV/PM <input type="radio"/> AOLV/PM <input type="radio"/> CLV/PM Sets the slip compensation gain used for motor 2.	Default: <1> Min.: 0.0 Max.: 2.5	50
C3-22 (241) 	Motor 2 Slip Compensation Primary Delay Time	<input checked="" type="radio"/> V/f <input type="radio"/> V/f w PG <input checked="" type="radio"/> OLV <input type="radio"/> CLV <input type="radio"/> OLV/PM <input type="radio"/> AOLV/PM <input type="radio"/> CLV/PM Sets the slip compensation delay time used for motor 2.	Default: <2> Min.: 0 ms Max.: 10000 ms	50
C3-23 (242)	Motor 2 Slip Compensation Limit	<input checked="" type="radio"/> V/f <input type="radio"/> V/f w PG <input checked="" type="radio"/> OLV <input type="radio"/> CLV <input type="radio"/> OLV/PM <input type="radio"/> AOLV/PM <input type="radio"/> CLV/PM Sets the upper limit for the slip compensation function for motor 2. Set as a percentage of the motor rated slip (E4-02).	Default: 200% Min.: 0 Max.: 250	51
C3-24 (243)	Motor 2 Slip Compensation Selection During Regeneration	<input checked="" type="radio"/> V/f <input type="radio"/> V/f w PG <input checked="" type="radio"/> OLV <input type="radio"/> CLV <input type="radio"/> OLV/PM <input type="radio"/> AOLV/PM <input type="radio"/> CLV/PM 0: Disabled. 1: Enabled above 6 Hz. 2: Enabled whenever slip compensation is possible.	Default: 0 Range: 0 to 2	51

<1> Default setting is determined by parameter A1-02, Control Method Selection.

<2> Default setting is determined by parameter E3-01, Motor 2 Control Mode Selection.

## ◆ C4: Torque Compensation







No. (Addr. Hex)	Name	Description	Values	Page
C4-01 (215) 	Torque Compensation Gain	<input checked="" type="radio"/> V/f <input checked="" type="radio"/> V/f w PG <input checked="" type="radio"/> OLV <input type="radio"/> CLV <input checked="" type="radio"/> OLV/PM <input type="radio"/> AOLV/PM <input type="radio"/> CLV/PM Sets the gain for the automatic torque (voltage) boost function and helps to produce better starting torque. Used for motor 1.	Default: <1> Min.: 0.00 Max.: 2.50	51
C4-02 (216) 	Torque Compensation Primary Delay Time 1	<input checked="" type="radio"/> V/f <input checked="" type="radio"/> V/f w PG <input checked="" type="radio"/> OLV <input type="radio"/> CLV <input checked="" type="radio"/> OLV/PM <input type="radio"/> AOLV/PM <input type="radio"/> CLV/PM Sets the torque compensation filter time.	Default: <2> Min.: 0 ms Max.: 60000 ms	52
C4-03 (217)	Torque Compensation at Forward Start	<input type="radio"/> V/f <input type="radio"/> V/f w PG <input checked="" type="radio"/> OLV <input type="radio"/> CLV <input type="radio"/> OLV/PM <input type="radio"/> AOLV/PM <input type="radio"/> CLV/PM Sets torque compensation at forward start as a percentage of motor torque.	Default: 0.0% Min.: 0.0 Max.: 200.0	52
C4-04 (218)	Torque Compensation at Reverse Start	<input type="radio"/> V/f <input type="radio"/> V/f w PG <input checked="" type="radio"/> OLV <input type="radio"/> CLV <input type="radio"/> OLV/PM <input type="radio"/> AOLV/PM <input type="radio"/> CLV/PM Sets torque compensation at reverse start as a percentage of motor torque.	Default: 0.0% Min.: -200.0 Max.: 0.0	52
C4-05 (219)	Torque Compensation Time Constant	<input type="radio"/> V/f <input type="radio"/> V/f w PG <input checked="" type="radio"/> OLV <input type="radio"/> CLV <input type="radio"/> OLV/PM <input type="radio"/> AOLV/PM <input type="radio"/> CLV/PM Sets the time constant for torque compensation at forward start and reverse start (C4-03 and C4-04).	Default: 10 ms Min.: 0 Max.: 200	52

No. (Addr. Hex)	Name	Description	Values	Page
C4-06 (21A)	Torque Compensation Primary Delay Time 2	<input type="radio"/> V/f <input type="radio"/> V/f w PG <input checked="" type="radio"/> OLV <input type="radio"/> CLV <input type="radio"/> OLV/PM <input type="radio"/> AOLV/PM <input type="radio"/> CLV/PM Sets the torque compensation time 2.	Default: 150 ms Min.: 0 Max.: 10000	52
C4-07 (341) 	Motor 2 Torque Compensation Gain	<input checked="" type="radio"/> V/f <input checked="" type="radio"/> V/f w PG <input checked="" type="radio"/> OLV <input type="radio"/> CLV <input type="radio"/> OLV/PM <input type="radio"/> AOLV/PM <input type="radio"/> CLV/PM Sets the torque compensation gain used for motor 2.	Default: 1.00 Min.: 0.00 Max.: 2.50	52

<1> Default setting is determined by parameter A1-02, Control Method Selection.

<2> Default setting is determined by parameters A1-02, Control Method Selection, and o2-04, Drive Model Selection.

## ◆ C5: Automatic Speed Regulator (ASR)

No. (Addr. Hex)	Name	Description	Values	Page
C5-01 (21B) 	ASR Proportional Gain 1	<input type="radio"/> V/f <input checked="" type="radio"/> V/f w PG <input type="radio"/> OLV <input checked="" type="radio"/> CLV <input type="radio"/> OLV/PM <input checked="" type="radio"/> AOLV/PM <input checked="" type="radio"/> CLV/PM Sets the proportional gain of the speed control loop (ASR).	Default: <1> Min.: 0.00 Max.: 300.00 <2>	54
C5-02 (21C) 	ASR Integral Time 1	<input type="radio"/> V/f <input checked="" type="radio"/> V/f w PG <input type="radio"/> OLV <input checked="" type="radio"/> CLV <input type="radio"/> OLV/PM <input checked="" type="radio"/> AOLV/PM <input checked="" type="radio"/> CLV/PM Sets the integral time of the speed control loop (ASR).	Default: <1> Min.: 0.000 s Max.: 10.000 s	54
C5-03 (21D) 	ASR Proportional Gain 2	<input type="radio"/> V/f <input checked="" type="radio"/> V/f w PG <input type="radio"/> OLV <input checked="" type="radio"/> CLV <input type="radio"/> OLV/PM <input checked="" type="radio"/> AOLV/PM <input checked="" type="radio"/> CLV/PM Sets the speed control gain 2 of the speed control loop (ASR).	Default: <1> Min.: 0.00 Max.: 300.00 <2>	54
C5-04 (21E) 	ASR Integral Time 2	<input type="radio"/> V/f <input checked="" type="radio"/> V/f w PG <input type="radio"/> OLV <input checked="" type="radio"/> CLV <input type="radio"/> OLV/PM <input checked="" type="radio"/> AOLV/PM <input checked="" type="radio"/> CLV/PM Sets the integral time 2 of the speed control loop (ASR).	Default: <1> Min.: 0.000 s Max.: 10.000 s	54
C5-05 (21F)	ASR Limit	<input type="radio"/> V/f <input checked="" type="radio"/> V/f w PG <input type="radio"/> OLV <input type="radio"/> CLV <input type="radio"/> OLV/PM <input type="radio"/> AOLV/PM <input type="radio"/> CLV/PM Sets the upper limit for the speed control loop (ASR) as a percentage of the maximum output frequency (E1-04).	Default: 5.0% Min.: 0.0 Max.: 20.0	56
C5-06 (220)	ASR Primary Delay Time Constant	<input type="radio"/> V/f <input type="radio"/> V/f w PG <input type="radio"/> OLV <input checked="" type="radio"/> CLV <input type="radio"/> OLV/PM <input checked="" type="radio"/> AOLV/PM <input checked="" type="radio"/> CLV/PM Sets the filter time constant for the time from the speed loop to the torque command output.	Default: <1> Min.: 0.000 s Max.: 0.500 s	56
C5-07 (221)	ASR Gain Switching Frequency	<input type="radio"/> V/f <input type="radio"/> V/f w PG <input type="radio"/> OLV <input checked="" type="radio"/> CLV <input type="radio"/> OLV/PM <input checked="" type="radio"/> AOLV/PM <input checked="" type="radio"/> CLV/PM Sets the frequency for switching between proportional gain 1, 2 and integral time 1, 2.	Default: 0.0 Hz Min.: 0.0 Max.: 400.0	56
C5-08 (222)	ASR Integral Limit	<input type="radio"/> V/f <input type="radio"/> V/f w PG <input type="radio"/> OLV <input checked="" type="radio"/> CLV <input type="radio"/> OLV/PM <input checked="" type="radio"/> AOLV/PM <input checked="" type="radio"/> CLV/PM Sets the ASR integral upper limit as a percentage of rated load torque.	Default: 400% Min.: 0 Max.: 400	56
C5-12 (386)	Integral Operation during Accel/Decel	<input type="radio"/> V/f <input checked="" type="radio"/> V/f w PG <input type="radio"/> OLV <input type="radio"/> CLV <input type="radio"/> OLV/PM <input type="radio"/> AOLV/PM <input type="radio"/> CLV/PM 0: Disabled. Integral functions are enabled only during constant speed. 1: Enabled. Integral functions are always enabled, during accel/dec and during constant speed.	Default: 0 Range: 0, 1	56
C5-21 (356) 	Motor 2 ASR Proportional Gain 1	<input type="radio"/> V/f <input checked="" type="radio"/> V/f w PG <input type="radio"/> OLV <input checked="" type="radio"/> CLV <input type="radio"/> OLV/PM <input type="radio"/> AOLV/PM <input type="radio"/> CLV/PM Sets the proportional gain of the speed control loop (ASR) for motor 2.	Default: <5> Min.: 0.00 Max.: 300.00 <2>	56
C5-22 (357) 	Motor 2 ASR Integral Time 1	<input type="radio"/> V/f <input checked="" type="radio"/> V/f w PG <input type="radio"/> OLV <input checked="" type="radio"/> CLV <input type="radio"/> OLV/PM <input type="radio"/> AOLV/PM <input type="radio"/> CLV/PM Sets the integral time of the speed control loop (ASR) for motor 2.	Default: <5> Min.: 0.000 s Max.: 10.000 s	56

## A.5 C: Tuning

No. (Addr. Hex)	Name	Description	Values	Page
C5-23 (358) 	Motor 2 ASR Proportional Gain 2	<input type="radio"/> V/f <input checked="" type="radio"/> V/f w PG <input type="radio"/> OLV <input checked="" type="radio"/> CLV <input type="radio"/> OLV/PM <input type="radio"/> AOLV/PM <input type="radio"/> CLV/PM Sets the speed control gain 2 of the speed control loop (ASR) for motor 2.	Default: <5> Min.: 0.00 Max.: 300.00 <2>	56
C5-24 (359) 	Motor 2 ASR Integral Time 2	<input type="radio"/> V/f <input checked="" type="radio"/> V/f w PG <input type="radio"/> OLV <input checked="" type="radio"/> CLV <input type="radio"/> OLV/PM <input type="radio"/> AOLV/PM <input type="radio"/> CLV/PM Sets the integral time 2 of the speed control loop (ASR) for motor 2.	Default: <5> Min.: 0.000 s Max.: 10.000 s	56
C5-25 (35A)	Motor 2 ASR Limit	<input type="radio"/> V/f <input checked="" type="radio"/> V/f w PG <input type="radio"/> OLV <input type="radio"/> CLV <input type="radio"/> OLV/PM <input type="radio"/> AOLV/PM <input type="radio"/> CLV/PM Sets the upper limit for the speed control loop (ASR) for motor 2 as a percentage of the maximum output frequency (E3-04).	Default: 5.0% Min.: 0.0 Max.: 20.0	57
C5-26 (35B)	Motor 2 ASR Primary Delay Time Constant	<input type="radio"/> V/f <input type="radio"/> V/f w PG <input type="radio"/> OLV <input checked="" type="radio"/> CLV <input type="radio"/> OLV/PM <input type="radio"/> AOLV/PM <input type="radio"/> CLV/PM Sets the filter time constant for the time from the speed loop to the torque command output used for motor 2.	Default: <5> Min.: 0.000 s Max.: 0.500 s	57
C5-27 (35C)	Motor 2 ASR Gain Switching Frequency	<input type="radio"/> V/f <input type="radio"/> V/f w PG <input type="radio"/> OLV <input checked="" type="radio"/> CLV <input type="radio"/> OLV/PM <input type="radio"/> AOLV/PM <input type="radio"/> CLV/PM Sets the frequency for motor 2 used to switch between proportional gain 1 and 2, and between the integral time 1 and 2.	Default: 0.0 Hz Min.: 0.0 Max.: 400.0	57
C5-28 (35D)	Motor 2 ASR Integral Limit	<input type="radio"/> V/f <input type="radio"/> V/f w PG <input type="radio"/> OLV <input checked="" type="radio"/> CLV <input type="radio"/> OLV/PM <input type="radio"/> AOLV/PM <input type="radio"/> CLV/PM Sets the ASR integral upper limit for motor 2 as a percentage of rated load torque.	Default: 400% Min.: 0 Max.: 400	57
C5-32 (361)	Integral Operation during Accel/Decel for Motor 2	<input type="radio"/> V/f <input checked="" type="radio"/> V/f w PG <input type="radio"/> OLV <input type="radio"/> CLV <input type="radio"/> OLV/PM <input type="radio"/> AOLV/PM <input type="radio"/> CLV/PM 0: Disabled. Integral functions for motor 2 are enabled only during constant speed. 1: Enabled. Integral functions are always enabled for motor 2, during accel/decel and during constant speed.	Default: 0 Range: 0, 1	57

- <1> Default setting is determined by parameter A1-02, Control Method Selection.  
 <2> The setting range is 1.00 to 300.00 in CLV and AOLV/PM control modes.  
 <5> Default setting is determined by parameter E3-01, Motor 2 Control Mode Selection.

## ◆ C6: Carrier Frequency

No. (Addr. Hex)	Name	Description	Values	Page
C6-01 (223)	Drive Duty Selection	<input checked="" type="radio"/> All Modes 0: Heavy Duty (HD) for constant torque applications. 1: Normal Duty (ND) for variable torque applications.	Default: 1 Range: 0, 1	57
C6-02 (224)	Carrier Frequency Selection	<input checked="" type="radio"/> All Modes 1: 2.0 kHz	Default: 1 Range: 1	58

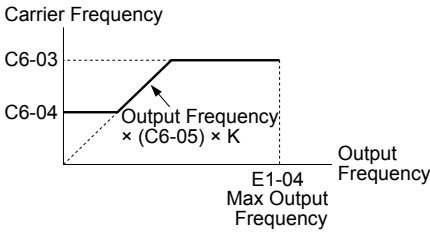

No. (Addr. Hex)	Name	Description	Values	Page
C6-05 (227)	Carrier Frequency Proportional Gain	<p><b>All Modes</b></p> <p><b>Note:</b> C6-04 and C6-05 are available only in V/f and V/f w/PG control modes.</p> <p>Determines the upper and lower limits for the carrier frequency. In OLV, C6-03 determines the upper limit of the carrier frequency.</p>  <p>The graph plots Carrier Frequency on the vertical axis and Output Frequency on the horizontal axis. A horizontal line at level C6-04 represents the carrier frequency for output frequencies up to C6-04. For output frequencies greater than C6-04, the carrier frequency increases linearly. The slope of this linear increase is labeled as <math>(C6-05) \times K</math>. The maximum output frequency is marked as E1-04. The upper limit of the carrier frequency is indicated by C6-03.</p>	Default: <2> Min.: 0 Max.: 99	58





<2> Default setting value is dependent on parameter C6-02, Carrier Frequency Selection.

## A.6 d: References

Reference parameters set the various frequency reference values during operation.

### ◆ d1: Frequency Reference

No. (Addr. Hex)	Name	Description	Values	Page
d1-01 (280) 	Frequency Reference 1	<b>All Modes</b> Sets the frequency reference for the drive. Setting units are determined by parameter o1-03.	Default: 0.00 Hz Min.: 0.00 Max.: 150.00 <?> <?>	59
d1-02 (281) 	Frequency Reference 2	<b>All Modes</b> Sets the frequency reference for the drive. Setting units are determined by parameter o1-03.	Default: 0.00 Hz Min.: 0.00 Max.: 150.00 <?> <?>	59
d1-03 (282) 	Frequency Reference 3	<b>All Modes</b> Sets the frequency reference for the drive. Setting units are determined by parameter o1-03.	Default: 0.00 Hz Min.: 0.00 Max.: 150.00 <?> <?>	59
d1-04 (283) 	Frequency Reference 4	<b>All Modes</b> Sets the frequency reference for the drive. Setting units are determined by parameter o1-03.	Default: 0.00 Hz Min.: 0.00 Max.: 150.00 <?> <?>	59
d1-05 (284) 	Frequency Reference 5	<b>All Modes</b> Sets the frequency reference for the drive. Setting units are determined by parameter o1-03.	Default: 0.00 Hz Min.: 0.00 Max.: 150.00 <?> <?>	59
d1-06 (285) 	Frequency Reference 6	<b>All Modes</b> Sets the frequency reference for the drive. Setting units are determined by parameter o1-03.	Default: 0.00 Hz Min.: 0.00 Max.: 150.00 <?> <?>	59
d1-07 (286) 	Frequency Reference 7	<b>All Modes</b> Sets the frequency reference for the drive. Setting units are determined by parameter o1-03.	Default: 0.00 Hz Min.: 0.00 Max.: 150.00 <?> <?>	59
d1-08 (287) 	Frequency Reference 8	<b>All Modes</b> Sets the frequency reference for the drive. Setting units are determined by parameter o1-03.	Default: 0.00 Hz Min.: 0.00 Max.: 150.00 <?> <?>	59
d1-09 (288) 	Frequency Reference 9	<b>All Modes</b> Sets the frequency reference for the drive. Setting units are determined by parameter o1-03.	Default: 0.00 Hz Min.: 0.00 Max.: 150.00 <?> <?>	59
d1-10 (28B) 	Frequency Reference 10	<b>All Modes</b> Sets the frequency reference for the drive. Setting units are determined by parameter o1-03.	Default: 0.00 Hz Min.: 0.00 Max.: 150.00 <?> <?>	59
d1-11 (28C) 	Frequency Reference 11	<b>All Modes</b> Sets the frequency reference for the drive. Setting units are determined by parameter o1-03.	Default: 0.00 Hz Min.: 0.00 Max.: 150.00 <?> <?>	59
d1-12 (28D) 	Frequency Reference 12	<b>All Modes</b> Sets the frequency reference for the drive. Setting units are determined by parameter o1-03.	Default: 0.00 Hz Min.: 0.00 Max.: 150.00 <?> <?>	59
d1-13 (28E) 	Frequency Reference 13	<b>All Modes</b> Sets the frequency reference for the drive. Setting units are determined by parameter o1-03.	Default: 0.00 Hz Min.: 0.00 Max.: 150.00 <?> <?>	59

No. (Addr. Hex)	Name	Description	Values	Page
d1-14 (28F) 	Frequency Reference 14	<b>All Modes</b> Sets the frequency reference for the drive. Setting units are determined by parameter o1-03.	Default: 0.00 Hz Min.: 0.00 Max.: 150.00 <1> <2>	59
d1-15 (290) 	Frequency Reference 15	<b>All Modes</b> Sets the frequency reference for the drive. Setting units are determined by parameter o1-03.	Default: 0.00 Hz Min.: 0.00 Max.: 150.00 <1> <2>	59
d1-16 (291) 	Frequency Reference 16	<b>All Modes</b> Sets the frequency reference for the drive. Setting units are determined by parameter o1-03.	Default: 0.00 Hz Min.: 0.00 Max.: 150.00 <1> <2>	59
d1-17 (292) 	Jog Frequency Reference	<b>All Modes</b> Sets the Jog frequency reference. Setting units are determined by parameter o1-03.	Default: 6.00 Hz Min.: 0.00 Max.: 150.00 <1> <2>	59

<1> Range upper limit is determined by parameters d2-01, Frequency Reference Upper Limit, and E1-04, Maximum Output Frequency.

<2> The setting range is 0.0 to 66.0 in AOLV/PM.

## ◆ d2: Frequency Upper/Lower Limits

No. (Addr. Hex.)	Name	Description	Setting	Page
d2-01 (289)	Frequency Reference Upper Limit	<b>All Modes</b> Sets the frequency reference upper limit as a percentage of the maximum output frequency.	Default: 100.0% Min.: 0.0 Max.: 110.0	61
d2-02 (28A)	Frequency Reference Lower Limit	<b>All Modes</b> Sets the frequency reference lower limit as a percentage of the maximum output frequency.	Default: 0.0% Min.: 0.0 Max.: 110.0	61
d2-03 (293)	Master Speed Reference Lower Limit	<b>All Modes</b> Sets the lower limit for frequency references from analog inputs as a percentage of the maximum output frequency.	Default: 0.0% Min.: 0.0 Max.: 110.0	62

## ◆ d3: Jump Frequency







No. (Addr. Hex)	Name	Description	Values	Page
d3-01 (294)	Jump Frequency 1	<b>All Modes</b> Eliminates problems with resonant vibration of the motor/machine by avoiding continuous operation in predefined frequency ranges. The drive accelerates and decelerates the motor through the prohibited frequency ranges. Setting 0.0 disables this function. Parameters must be set so that $d3-01 \geq d3-02 \geq d3-03$ .	Default: 0.0 Hz Min.: 0.0 Max.: 150.0	62
d3-02 (295)	Jump Frequency 2	<b>All Modes</b> Eliminates problems with resonant vibration of the motor/machine by avoiding continuous operation in predefined frequency ranges. The drive accelerates and decelerates the motor through the prohibited frequency ranges. Setting 0.0 disables this function. Parameters must be set so that $d3-01 \geq d3-02 \geq d3-03$ .	Default: 0.0 Hz Min.: 0.0 Max.: 150.0	62
d3-03 (296)	Jump Frequency 3	<b>All Modes</b> Eliminates problems with resonant vibration of the motor/machine by avoiding continuous operation in predefined frequency ranges. The drive accelerates and decelerates the motor through the prohibited frequency ranges. Setting 0.0 disables this function. Parameters must be set so that $d3-01 \geq d3-02 \geq d3-03$ .	Default: 0.0 Hz Min.: 0.0 Max.: 150.0	62

## A.6 d: References

No. (Addr. Hex)	Name	Description	Values	Page
d3-04 (297)	Jump Frequency Width	<b>All Modes</b> Sets the dead-band width around each selected prohibited frequency reference point.	Default: <1> Min.: 0.0 Max.: 20.0	62

<1> Default setting is determined by parameter A1-02, Control Mode Setting.

### ◆ d4: Frequency Reference Hold and Up/Down 2 Function

No. (Addr. Hex)	Name	Description	Values	Page
d4-01 (298)	Frequency Reference Hold Function Selection	<b>All Modes</b> 0: Disabled. Drive starts from zero when the power is switched on. 1: Enabled. At power up, the drive starts the motor at the Hold frequency that was saved.	Default: 0 Range: 0, 1	63
d4-03 (2AA) 	Frequency Reference Bias Step (Up/Down 2)	<b>All Modes</b> Sets the bias added to the frequency reference when the Up 2 and Down 2 digital inputs are enabled (H1-□□ = 75, 76).	Default: 0.00 Hz Min.: 0.00 Max.: 99.99	65
d4-04 (2AB) 	Frequency Reference Bias Accel/Decel (Up/Down 2)	<b>All Modes</b> 0: Use selected accel/decel time. 1: Use accel/decel time 4 (C1-07 and C1-08).	Default: 0 Range: 0, 1	66
d4-05 (2AC) 	Frequency Reference Bias Operation Mode Selection (Up/Down 2)	<b>All Modes</b> 0: Bias value is held if no input Up 2 or Down 2 is active. 1: When the Up 2 reference and Down 2 reference are both on or both off, the applied bias becomes 0. The specified accel/decel times are used for acceleration or deceleration.	Default: 0 Range: 0, 1	66
d4-06 (2AD)	Frequency Reference Bias (Up/Down 2)	<b>All Modes</b> The Up/Down 2 bias value is saved in d4-06 when the frequency reference is not input by the digital operator. Set as a percentage of the maximum output frequency.	Default: 0.0% Min.: -99.9 Max.: 100.0	66
d4-07 (2AE) 	Analog Frequency Reference Fluctuation Limit (Up/Down 2)	<b>All Modes</b> Limits how much the frequency reference is allowed to change while an input terminal set for Up 2 or Down 2 is enabled. If the frequency reference changes for more than the set value, then the bias value is held and the drive accelerates or decelerates to the frequency reference. Set as a percentage of the maximum output frequency.	Default: 1.0% Min.: 0.1 Max.: 100.0	67
d4-08 (2AF) 	Frequency Reference Bias Upper Limit (Up/Down 2)	<b>All Modes</b> Sets the upper limit for the bias and the value that can be saved in d4-06. Set as a percentage of the maximum output frequency.	Default: 100.0% Min.: 0.0 Max.: 100.0	67
d4-09 (2B0) 	Frequency Reference Bias Lower Limit (Up/Down 2)	<b>All Modes</b> Sets the lower limit for the bias and the value that can be saved in d4-06. Set as a percentage of the maximum output frequency.	Default: 0.0% Min.: -99.9 Max.: 0.0	67
d4-10 (2B6)	Up/Down Frequency Reference Limit Selection	<b>All Modes</b> 0: The lower limit is determined by d2-02 or an analog input. 1: The lower limit is determined by d2-02.	Default: 0 Range: 0, 1	67

## ◆ d5: Torque Control

No. (Addr. Hex.)	Name	Description	Values	Page
d5-01 (29A)	Torque Control Selection	<div style="display: flex; justify-content: space-between; align-items: center;"> <span><input type="radio"/> V/f</span> <span><input type="radio"/> V/f w PG</span> <span><input type="radio"/> OLV</span> <span><input checked="" type="radio"/> CLV</span> </div> <div style="display: flex; justify-content: space-between; align-items: center;"> <span><input type="radio"/> OLV/PM</span> <span><input type="radio"/> AOLV/PM</span> <span><input checked="" type="radio"/> CLV/PM</span> </div> <p>0: Speed Control 1: Torque Control Set to 0 when using a digital input to switch between Speed and Torque Control (H1-□□ = 71).</p>	Default: 0 Range: 0, 1	71
d5-02 (29B)	Torque Reference Delay Time	<div style="display: flex; justify-content: space-between; align-items: center;"> <span><input type="radio"/> V/f</span> <span><input type="radio"/> V/f w PG</span> <span><input type="radio"/> OLV</span> <span><input checked="" type="radio"/> CLV</span> </div> <div style="display: flex; justify-content: space-between; align-items: center;"> <span><input type="radio"/> OLV/PM</span> <span><input type="radio"/> AOLV/PM</span> <span><input checked="" type="radio"/> CLV/PM</span> </div> <p>Sets a delay time for the torque reference signal. Used to suppress effects by noisy or fluctuating torque reference signals.</p>	Default: 0 ms Min.: 0 Max.: 1000	71
d5-03 (29C)	Speed Limit Selection	<div style="display: flex; justify-content: space-between; align-items: center;"> <span><input type="radio"/> V/f</span> <span><input type="radio"/> V/f w PG</span> <span><input type="radio"/> OLV</span> <span><input checked="" type="radio"/> CLV</span> </div> <div style="display: flex; justify-content: space-between; align-items: center;"> <span><input type="radio"/> OLV/PM</span> <span><input type="radio"/> AOLV/PM</span> <span><input checked="" type="radio"/> CLV/PM</span> </div> <p>1: Limit set by the frequency reference in b1-01. 2: Limit set by d5-04.</p>	Default: 1 Range: 1, 2	71
d5-04 (29D)	Speed Limit	<div style="display: flex; justify-content: space-between; align-items: center;"> <span><input type="radio"/> V/f</span> <span><input type="radio"/> V/f w PG</span> <span><input type="radio"/> OLV</span> <span><input checked="" type="radio"/> CLV</span> </div> <div style="display: flex; justify-content: space-between; align-items: center;"> <span><input type="radio"/> OLV/PM</span> <span><input type="radio"/> AOLV/PM</span> <span><input checked="" type="radio"/> CLV/PM</span> </div> <p>Sets the speed limit during Torque Control as a percentage of the maximum output frequency. Enabled when d5-03 = 2. A negative setting sets a limit in the opposite direction of the Run command.</p>	Default: 0% Min.: -120 Max.: 120	71
d5-05 (29E)	Speed Limit Bias	<div style="display: flex; justify-content: space-between; align-items: center;"> <span><input type="radio"/> V/f</span> <span><input type="radio"/> V/f w PG</span> <span><input type="radio"/> OLV</span> <span><input checked="" type="radio"/> CLV</span> </div> <div style="display: flex; justify-content: space-between; align-items: center;"> <span><input type="radio"/> OLV/PM</span> <span><input type="radio"/> AOLV/PM</span> <span><input checked="" type="radio"/> CLV/PM</span> </div> <p>Sets the speed limit bias as a percentage of the maximum output frequency. The bias is applied to the specified speed limit and can adjust the margin for the speed limit.</p>	Default: 10% Min.: 0 Max.: 120	71
d5-06 (29F)	Speed/Torque Control Switchover Time	<div style="display: flex; justify-content: space-between; align-items: center;"> <span><input type="radio"/> V/f</span> <span><input type="radio"/> V/f w PG</span> <span><input type="radio"/> OLV</span> <span><input checked="" type="radio"/> CLV</span> </div> <div style="display: flex; justify-content: space-between; align-items: center;"> <span><input type="radio"/> OLV/PM</span> <span><input type="radio"/> AOLV/PM</span> <span><input checked="" type="radio"/> CLV/PM</span> </div> <p>Sets the delay time for switching between Speed and Torque Control using an input terminal (H1-□□ = 71). Reference values are held during this switch delay time.</p>	Default: 0 ms Min.: 0 Max.: 1000	72
d5-08 (2B5)	Unidirectional Speed Limit Bias	<div style="display: flex; justify-content: space-between; align-items: center;"> <span><input type="radio"/> V/f</span> <span><input type="radio"/> V/f w PG</span> <span><input type="radio"/> OLV</span> <span><input checked="" type="radio"/> CLV</span> </div> <div style="display: flex; justify-content: space-between; align-items: center;"> <span><input type="radio"/> OLV/PM</span> <span><input type="radio"/> AOLV/PM</span> <span><input checked="" type="radio"/> CLV/PM</span> </div> <p>0: Disabled 1: Enabled</p>	Default: 1 Range: 0, 1	72



## ◆ d6: Field Weakening and Field Forcing

No. (Addr. Hex.)	Name	Description	Values	Page
d6-01 (2A0)	Field Weakening Level	<div style="display: flex; justify-content: space-between; align-items: center;"> <span><input checked="" type="radio"/> V/f</span> <span><input checked="" type="radio"/> V/f w PG</span> <span><input type="radio"/> OLV</span> <span><input type="radio"/> CLV</span> </div> <div style="display: flex; justify-content: space-between; align-items: center;"> <span><input type="radio"/> OLV/PM</span> <span><input type="radio"/> AOLV/PM</span> <span><input type="radio"/> CLV/PM</span> </div> <p>Sets the drive output voltage for the Field Weakening function as a percentage of the maximum output voltage. Enabled when a multi-function input is set for Field Weakening (H1-□□ = 63).</p>	Default: 80% Min.: 0 Max.: 100	72
d6-02 (2A1)	Field Weakening Frequency Limit	<div style="display: flex; justify-content: space-between; align-items: center;"> <span><input checked="" type="radio"/> V/f</span> <span><input checked="" type="radio"/> V/f w PG</span> <span><input type="radio"/> OLV</span> <span><input type="radio"/> CLV</span> </div> <div style="display: flex; justify-content: space-between; align-items: center;"> <span><input type="radio"/> OLV/PM</span> <span><input type="radio"/> AOLV/PM</span> <span><input type="radio"/> CLV/PM</span> </div> <p>Sets the lower limit of the frequency range where Field Weakening control is valid. The Field Weakening command is valid only at frequencies above this setting and only when the output frequency matches the frequency reference (speed agree).</p>	Default: 0.0 Hz Min.: 0.0 Max.: 150.0	72
d6-03 (2A2)	Field Forcing Selection	<div style="display: flex; justify-content: space-between; align-items: center;"> <span><input type="radio"/> V/f</span> <span><input type="radio"/> V/f w PG</span> <span><input checked="" type="radio"/> OLV</span> <span><input checked="" type="radio"/> CLV</span> </div> <div style="display: flex; justify-content: space-between; align-items: center;"> <span><input type="radio"/> OLV/PM</span> <span><input type="radio"/> AOLV/PM</span> <span><input type="radio"/> CLV/PM</span> </div> <p>0: Disabled 1: Enabled</p>	Default: 0 Range: 0, 1	73

## A.6 d: References

No. (Addr Hex.)	Name	Description	Values	Page
d6-06 (2A5)	Field Forcing Limit	<div style="display: flex; justify-content: space-between; align-items: center;"> <span>V/f</span> <span>V/f w PG</span> <span><b>OLV</b></span> <span><b>CLV</b></span> </div> <div style="display: flex; justify-content: space-between; align-items: center; margin-top: 5px;"> <span>OLV/PM</span> <span>AOLV/PM</span> <span>CLV/PM</span> </div> <p>Sets the upper limit of the excitation current command during magnetic field forcing. A setting of 100% is equal to motor no-load current. Disabled only during DC Injection Braking.</p>	Default: 400% Min.: 100 Max.: 400	<a href="#">73</a>

## ◆ d7: Offset Frequency

No. (Addr. Hex)	Name	Description	Setting	Page
d7-01 (2B2) 	Offset Frequency 1	<p><b>All Modes</b></p> <p>Added to the frequency reference when the digital input “Frequency offset 1” (H1-□□ = 44) is switched on.</p>	Default: 0.0% Min.: -100.0 Max.: 100.0	<a href="#">73</a>
d7-02 (2B3) 	Offset Frequency 2	<p><b>All Modes</b></p> <p>Added to the frequency reference when the digital input “Frequency offset 2” (H1-□□ = 45) is switched on.</p>	Default: 0.0% Min.: -100.0 Max.: 100.0	<a href="#">73</a>
d7-03 (2B4) 	Offset Frequency 3	<p><b>All Modes</b></p> <p>Added to the frequency reference when the digital input “Frequency offset 3” (H1-□□ = 46) is switched on.</p>	Default: 0.0% Min.: -100.0 Max.: 100.0	<a href="#">73</a>

# A.7 E: Motor Parameters

## ◆ E1: V/f Pattern for Motor 1

No. (Addr. Hex)	Name	Description	Values	Page
E1-01 (300)	Input Voltage Setting	<p><b>All Modes</b></p> <p>This parameter must be set to the power supply voltage.</p> <p><b>WARNING! Electrical Shock Hazard. Drive input voltage (not motor voltage) must be set in E1-01 for the protective features of the drive to function properly. Failure to do so may result in equipment damage and/or death or personal injury.</b></p>	Default: 400 V <I> Min.: 155 Max.: 510 <I>	74
E1-03 (302)	V/f Pattern Selection	<p> <input checked="" type="radio"/> V/f                                <input type="radio"/> V/f w PG                                <input checked="" type="radio"/> OLV                                <input type="radio"/> CLV  <input type="radio"/> OLV/PM    <input type="radio"/> AOLV/PM    <input type="radio"/> CLV/PM                         </p> <p>                             0: 50 Hz, Constant torque 1                              1: 60 Hz, Constant torque 2                              2: 60 Hz, Constant torque 3 (50 Hz base)                              3: 72 Hz, Constant torque 4 (60 Hz base)                              4: 50 Hz, Variable torque 1                              5: 50 Hz, Variable torque 2                              6: 60 Hz, Variable torque 3                              7: 60 Hz, Variable torque 4                              8: 50 Hz, High starting torque 1                              9: 50 Hz, High starting torque 2                              A: 60 Hz, High starting torque 3                              B: 60 Hz, High starting torque 4                              C: 90 Hz (60 Hz base)                              D: 120 Hz (60 Hz base)                              E: 180 Hz (60 Hz base)                              F: Custom V/f, E1-04 through E1-13 settings define the V/f pattern                         </p>	Default: F <2> Range: 0 to 9; A to F <2>	74
E1-04 (303)	Maximum Output Frequency	<p><b>All Modes</b></p> <p>These parameters are only applicable when E1-03 is set to F. To set linear V/f characteristics, set the same values for E1-07 and E1-09. In this case, the setting for E1-08 will be disregarded. Ensure that the four frequencies are set according to these rules:  <math>E1-09 \leq E1-07 &lt; E1-06 \leq E1-11 \leq E1-04</math></p> <p>Output Voltage (V)</p> <p>Frequency (Hz)</p> <p><b>Note:</b> Some parameters may not be available depending on the control mode.</p> <ul style="list-style-type: none"> <li>E1-07, E1-08, and E1-10 are available only in the following control modes: V/f Control, V/f with PG, Open Loop Vector.</li> <li>E1-11, E1-12, and E1-13 are available only in the following control modes: V/f Control, V/f with PG, Open Loop Vector, Closed Loop Vector.</li> </ul>	Default: <I> Min.: 40.0 Max.: 150.0	76
E1-05 (304)	Maximum Voltage		Default: <I> Min.: 0.0 V Max.: 510.0 V <I>	76
E1-06 (305)	Base Frequency		Default: <I> Min.: 0.0 Max.: 150.0	76
E1-07 (306)	Middle Output Frequency		Default: <I> Min.: 0.0 Max.: 150.0	76
E1-08 (307)	Middle Output Frequency Voltage		Default: <I> Min.: 0.0 V Max.: 510.0 V <I>	76
E1-09 (308)	Minimum Output Frequency		Default: <I> Min.: 0.0 Max.: 150.0	76
E1-10 (309)	Minimum Output Frequency Voltage		Default: <I> Min.: 0.0 V Max.: 510.0 V <I>	76
E1-11 (30A) <2>	Middle Output Frequency 2		Default: 0.0 Hz Min.: 0.0 Max.: 150.0	76
E1-12 (30B) <2>	Middle Output Frequency Voltage 2		Default: 0.0 V Min.: 0.0 Max.: 510.0 V <I>	76
E1-13 (30C)	Base Voltage		Default: 0.0 V <2> Min.: 0.0 Max.: 510.0 V <I>	76

<I> Values shown are specific to 400 V class drives. Multiply the value by 1.4375 for 600 V class and 690 V class drives.

## A.7 E: Motor Parameters

- <2> Parameter setting value is not reset to the default value when the drive is initialized.
- <3> The setting value is F in OLV modes.
- <4> Default setting is dependent on parameters A1-02, Control Model Selection, C6-01, Drive Duty Selection, and o2-04, Drive Model Selection.
- <8> When Auto-Tuning is performed, E1-13 and E1-05 will be set to the same value.
- <9> Parameter ignored when E1-11 (Motor 1 Mid Output Frequency 2) and E1-12 (Motor 1 Mid Output Frequency Voltage 2) are set to 0.0.

### ◆ E2: Motor 1 Parameters

No. (Addr. Hex)	Name	Description	Values	Page
E2-01 (30E)	Motor Rated Current	<div style="display: flex; justify-content: space-between; align-items: center;"> <span><input checked="" type="radio"/> V/f</span> <span><input checked="" type="radio"/> V/f w PG</span> <span><input checked="" type="radio"/> OLV</span> <span><input checked="" type="radio"/> CLV</span> </div> <div style="display: flex; justify-content: space-between; align-items: center; margin-top: 5px;"> <span><input type="radio"/> OLV/PM</span> <span><input type="radio"/> AOLV/PM</span> <span><input type="radio"/> CLV/PM</span> </div> <p>Sets the motor nameplate full load current in amps. Automatically set during Auto-Tuning.</p>	Default: <1> Min.: 10% of drive rated current Max.: 200% of drive rated current <2>	77
E2-02 (30F)	Motor Rated Slip	<div style="display: flex; justify-content: space-between; align-items: center;"> <span><input checked="" type="radio"/> V/f</span> <span><input checked="" type="radio"/> V/f w PG</span> <span><input checked="" type="radio"/> OLV</span> <span><input checked="" type="radio"/> CLV</span> </div> <div style="display: flex; justify-content: space-between; align-items: center; margin-top: 5px;"> <span><input type="radio"/> OLV/PM</span> <span><input type="radio"/> AOLV/PM</span> <span><input type="radio"/> CLV/PM</span> </div> <p>Sets the motor rated slip. Automatically set during Auto-Tuning.</p>	Default: <1> Min.: 0.00 Hz Max.: 20.00 Hz	77
E2-03 (310)	Motor No-Load Current	<div style="display: flex; justify-content: space-between; align-items: center;"> <span><input checked="" type="radio"/> V/f</span> <span><input checked="" type="radio"/> V/f w PG</span> <span><input checked="" type="radio"/> OLV</span> <span><input checked="" type="radio"/> CLV</span> </div> <div style="display: flex; justify-content: space-between; align-items: center; margin-top: 5px;"> <span><input type="radio"/> OLV/PM</span> <span><input type="radio"/> AOLV/PM</span> <span><input type="radio"/> CLV/PM</span> </div> <p>Sets the no-load current for the motor. Automatically set during Auto-Tuning.</p>	Default: <1> Min.: 0 A Max.: E2-01 <2>	77
E2-04 (311)	Number of Motor Poles	<div style="display: flex; justify-content: space-between; align-items: center;"> <span><input checked="" type="radio"/> V/f</span> <span><input checked="" type="radio"/> V/f w PG</span> <span><input checked="" type="radio"/> OLV</span> <span><input checked="" type="radio"/> CLV</span> </div> <div style="display: flex; justify-content: space-between; align-items: center; margin-top: 5px;"> <span><input type="radio"/> OLV/PM</span> <span><input type="radio"/> AOLV/PM</span> <span><input type="radio"/> CLV/PM</span> </div> <p>Sets the number of motor poles. Automatically set during Auto-Tuning.</p>	Default: 4 Min.: 2 Max.: 48	78
E2-05 (312)	Motor Line-to-Line Resistance	<div style="display: flex; justify-content: space-between; align-items: center;"> <span><input checked="" type="radio"/> V/f</span> <span><input checked="" type="radio"/> V/f w PG</span> <span><input checked="" type="radio"/> OLV</span> <span><input checked="" type="radio"/> CLV</span> </div> <div style="display: flex; justify-content: space-between; align-items: center; margin-top: 5px;"> <span><input type="radio"/> OLV/PM</span> <span><input type="radio"/> AOLV/PM</span> <span><input type="radio"/> CLV/PM</span> </div> <p>Sets the phase-to-phase motor resistance. Automatically set during Auto-Tuning.</p>	Default: <1> Min.: 0 mΩ Max.: 65000 mΩ	78
E2-06 (313)	Motor Leakage Inductance	<div style="display: flex; justify-content: space-between; align-items: center;"> <span><input checked="" type="radio"/> V/f</span> <span><input checked="" type="radio"/> V/f w PG</span> <span><input checked="" type="radio"/> OLV</span> <span><input checked="" type="radio"/> CLV</span> </div> <div style="display: flex; justify-content: space-between; align-items: center; margin-top: 5px;"> <span><input type="radio"/> OLV/PM</span> <span><input type="radio"/> AOLV/PM</span> <span><input type="radio"/> CLV/PM</span> </div> <p>Sets the voltage drop due to motor leakage inductance as a percentage of motor rated voltage. Automatically set during Auto-Tuning.</p>	Default: <1> Min.: 0.0% Max.: 40.0%	78
E2-07 (314)	Motor Iron-Core Saturation Coefficient 1	<div style="display: flex; justify-content: space-between; align-items: center;"> <span><input type="radio"/> V/f</span> <span><input type="radio"/> V/f w PG</span> <span><input checked="" type="radio"/> OLV</span> <span><input checked="" type="radio"/> CLV</span> </div> <div style="display: flex; justify-content: space-between; align-items: center; margin-top: 5px;"> <span><input type="radio"/> OLV/PM</span> <span><input type="radio"/> AOLV/PM</span> <span><input type="radio"/> CLV/PM</span> </div> <p>Sets the motor iron saturation coefficient at 50% of magnetic flux. Automatically set during Auto-Tuning.</p>	Default: 0.50 Min.: E2-07 Max.: 0.50	78
E2-08 (315)	Motor Iron-Core Saturation Coefficient 2	<div style="display: flex; justify-content: space-between; align-items: center;"> <span><input type="radio"/> V/f</span> <span><input type="radio"/> V/f w PG</span> <span><input checked="" type="radio"/> OLV</span> <span><input checked="" type="radio"/> CLV</span> </div> <div style="display: flex; justify-content: space-between; align-items: center; margin-top: 5px;"> <span><input type="radio"/> OLV/PM</span> <span><input type="radio"/> AOLV/PM</span> <span><input type="radio"/> CLV/PM</span> </div> <p>Sets the motor iron saturation coefficient at 75% of magnetic flux. Automatically set during Auto-Tuning.</p>	Default: 0.75 Min.: E2-07 Max.: 0.75	78
E2-09 (316)	Motor Mechanical Loss	<div style="display: flex; justify-content: space-between; align-items: center;"> <span><input type="radio"/> V/f</span> <span><input type="radio"/> V/f w PG</span> <span><input checked="" type="radio"/> OLV</span> <span><input checked="" type="radio"/> CLV</span> </div> <div style="display: flex; justify-content: space-between; align-items: center; margin-top: 5px;"> <span><input type="radio"/> OLV/PM</span> <span><input type="radio"/> AOLV/PM</span> <span><input type="radio"/> CLV/PM</span> </div> <p>Sets the motor mechanical loss as a percentage of motor rated power (kW).</p>	Default: 0.0% Min.: 0.0 Max.: 10.0	78
E2-10 (317)	Motor Iron Loss for Torque Compensation	<div style="display: flex; justify-content: space-between; align-items: center;"> <span><input checked="" type="radio"/> V/f</span> <span><input checked="" type="radio"/> V/f w PG</span> <span><input type="radio"/> OLV</span> <span><input type="radio"/> CLV</span> </div> <div style="display: flex; justify-content: space-between; align-items: center; margin-top: 5px;"> <span><input type="radio"/> OLV/PM</span> <span><input type="radio"/> AOLV/PM</span> <span><input type="radio"/> CLV/PM</span> </div> <p>Sets the motor iron loss.</p>	Default: <1> Min.: 0 W Max.: 65535 W	79
E2-11 (318)	Motor Rated Power	<div style="display: flex; justify-content: space-between; align-items: center;"> <span><input checked="" type="radio"/> V/f</span> <span><input checked="" type="radio"/> V/f w PG</span> <span><input checked="" type="radio"/> OLV</span> <span><input checked="" type="radio"/> CLV</span> </div> <div style="display: flex; justify-content: space-between; align-items: center; margin-top: 5px;"> <span><input type="radio"/> OLV/PM</span> <span><input type="radio"/> AOLV/PM</span> <span><input type="radio"/> CLV/PM</span> </div> <p>Sets the motor rated power in kilowatts (1 HP = 0.746 kW). Automatically set during Auto-Tuning.</p>	Default: <1> Min.: 0.00 kW Max.: 650.00 kW	79

- <1> Default setting is dependent on parameters C6-01, Drive Duty Selection, and o2-04, Drive Model Selection.
- <2> The number of decimal places in the parameter value depends on the drive model and the ND/HD selection in parameter C6-01. This value has two decimal places (0.01 A) if the drive is set for a maximum applicable motor capacity up to and including 11 kW, and one decimal place (0.1 A) if the maximum applicable motor capacity is higher than 11 kW.



◆ E3: V/f Pattern for Motor 2

These parameters are hidden when a PM motor control mode has been selected for motor 1 (A1-02 = 5, 6, 7).

No. (Addr. Hex)	Name	Description	Values	Page
E3-01 (319)	Motor 2 Control Mode Selection	<div style="display: flex; justify-content: space-around;"> <span>V/f</span> <span>V/f w PG</span> <span>OLV</span> <span>CLV</span> </div> <div style="display: flex; justify-content: space-around; margin-top: 5px;"> <span>OLV/PM</span> <span>AOLV/PM</span> <span>CLV/PM</span> </div> <p>0: V/f Control 1: V/f Control with PG 2: Open Loop Vector Control 3: Closed Loop Vector Control</p>	Default: 0 Range: 0 to 3	80
E3-04 (31A)	Motor 2 Maximum Output Frequency	<div style="display: flex; justify-content: space-around;"> <span>V/f</span> <span>V/f w PG</span> <span>OLV</span> <span>CLV</span> </div> <div style="display: flex; justify-content: space-around; margin-top: 5px;"> <span>OLV/PM</span> <span>AOLV/PM</span> <span>CLV/PM</span> </div>	Default: </> Min.: 40.0 Max.: 150.0	80
E3-05 (31B)	Motor 2 Maximum Voltage	<p>These parameters are only applicable when E1-03 is set to F. To set linear V/f characteristics, set the same values for E3-07 and E3-09. In this case, the setting for E3-08 will be disregarded. Ensure that the four frequencies are set according to these rules or an oPE10 fault will occur: E3-09 ≤ E3-07 &lt; E3-06 ≤ E3-11 ≤ E3-04</p> <p style="text-align: center;">Output Voltage (V)</p> <p style="text-align: center;">E3-09   E3-07   E3-06   E3-11   E3-04 Frequency (Hz)</p> <p><b>Note:</b> E3-07 and E3-08 are only available in the following control modes: V/f, V/f w/PG and OLV.</p>	Default: </> Min.: 0.0 V Max.: 510.0 V <2>	80
E3-06 (31C)	Motor 2 Base Frequency		Default: </> Min.: 0.0 Max.: 150.0	80
E3-07 (31D)	Motor 2 Mid Output Frequency		Default: </> Min.: 0.0 Max.: 150.0	80
E3-08 (31E)	Motor 2 Mid Output Frequency Voltage		Default: </> Min.: 0.0 V Max.: 510.0 V <2>	80
E3-09 (31F)	Motor 2 Minimum Output Frequency		Default: </> Min.: 0.0 Max.: 150.0	80
E3-10 (320)	Motor 2 Minimum Output Frequency Voltage		Default: </> Min.: 0.0 V Max.: 510.0 V <2>	80
E3-11 (345) <3>	Motor 2 Mid Output Frequency 2		Default: 0.0 Min.: 0.0 Max.: 150.0 <4>	80
E3-12 (346) <3>	Motor 2 Mid Output Frequency Voltage 2		Default: 0.0 V Min.: 0.0 Max.: 510.0 <2>	80
E3-13 (347)	Motor 2 Base Voltage		Default: 0.0 V <5> Min.: 0.0 Max.: 510.0 <2>	80

- <1> Default setting is dependent on E3-01, Motor 2 Control Mode Selection. The value shown here is for V/f Control (0).
- <2> Values shown are specific to 400 V class drives. Multiply the value by 1.4375 for 575 V class drives. Multiply the value by 1.725 for 690 V class drives.
- <3> Ignored when E3-11, Motor 2 Mid Output Frequency 2, and E3-12, Motor 2 Mid Output Frequency Voltage 2, are set to 0.
- <4> The setting range is 0.0 to 66.0 in AOLV/PM.
- <5> When Auto-Tuning is performed, E1-13 and E1-05 will be set to the same value.

**◆ E4: Motor 2 Parameters**

These parameters are hidden when a PM motor control mode has been selected for motor 1 (A1-02 = 5, 6, 7).

No. (Addr. Hex)	Name	Description	Values	Page
E4-01 (321)	Motor 2 Rated Current	<p><input checked="" type="radio"/> V/f   <input checked="" type="radio"/> V/f w PG   <input checked="" type="radio"/> OLV   <input checked="" type="radio"/> CLV</p> <p><input type="radio"/> OLV/PM   <input type="radio"/> AOLV/PM   <input type="radio"/> CLV/PM</p> <p>Sets the full load current for motor 2. Automatically set during Auto-Tuning.</p>	Default: <1> Min.: 10% of drive rated current Max.: 200% of drive rated current <2>	81
E4-02 (322)	Motor 2 Rated Slip	<p><input checked="" type="radio"/> V/f   <input checked="" type="radio"/> V/f w PG   <input checked="" type="radio"/> OLV   <input checked="" type="radio"/> CLV</p> <p><input type="radio"/> OLV/PM   <input type="radio"/> AOLV/PM   <input type="radio"/> CLV/PM</p> <p>Sets the rated slip for motor 2. Automatically set during Auto-Tuning.</p>	Default: <1> Min.: 0.00 Hz Max.: 20.00 Hz <2>	81
E4-03 (323)	Motor 2 Rated No-Load Current	<p><input checked="" type="radio"/> V/f   <input checked="" type="radio"/> V/f w PG   <input checked="" type="radio"/> OLV   <input checked="" type="radio"/> CLV</p> <p><input type="radio"/> OLV/PM   <input type="radio"/> AOLV/PM   <input type="radio"/> CLV/PM</p> <p>Sets the no-load current for motor 2. Automatically set during Auto-Tuning.</p>	Default: <1> Min.: 0 A Max.: E4-01 <2>	81
E4-04 (324)	Motor 2 Motor Poles	<p><input checked="" type="radio"/> V/f   <input checked="" type="radio"/> V/f w PG   <input checked="" type="radio"/> OLV   <input checked="" type="radio"/> CLV</p> <p><input type="radio"/> OLV/PM   <input type="radio"/> AOLV/PM   <input type="radio"/> CLV/PM</p> <p>Sets the number of poles of motor 2. Automatically set during Auto-Tuning.</p>	Default: 4 Min.: 2 Max.: 48	82
E4-05 (325)	Motor 2 Line-to-Line Resistance	<p><input checked="" type="radio"/> V/f   <input checked="" type="radio"/> V/f w PG   <input checked="" type="radio"/> OLV   <input checked="" type="radio"/> CLV</p> <p><input type="radio"/> OLV/PM   <input type="radio"/> AOLV/PM   <input type="radio"/> CLV/PM</p> <p>Sets the phase-to-phase resistance for motor 2. Automatically set during Auto-Tuning.</p>	Default: <1> Min.: 0mΩ Max.: 65000 mΩ	82
E4-06 (326)	Motor 2 Leakage Inductance	<p><input checked="" type="radio"/> V/f   <input checked="" type="radio"/> V/f w PG   <input checked="" type="radio"/> OLV   <input checked="" type="radio"/> CLV</p> <p><input type="radio"/> OLV/PM   <input type="radio"/> AOLV/PM   <input type="radio"/> CLV/PM</p> <p>Sets the voltage drop for motor 2 due to motor leakage inductance as a percentage of rated voltage. Automatically set during Auto-Tuning.</p>	Default: <1> Min.: 0.0% Max.: 40.0%	82
E4-07 (343)	Motor 2 Motor Iron-Core Saturation Coefficient 1	<p><input type="radio"/> V/f   <input type="radio"/> V/f w PG   <input checked="" type="radio"/> OLV   <input checked="" type="radio"/> CLV</p> <p><input type="radio"/> OLV/PM   <input type="radio"/> AOLV/PM   <input type="radio"/> CLV/PM</p> <p>Set to the motor iron saturation coefficient at 50% of magnetic flux for motor 2. Automatically set during Auto-Tuning.</p>	Default: 0.50 Min.: 0.00 Max.: 0.50	82
E4-08 (344)	Motor 2 Motor Iron-Core Saturation Coefficient 2	<p><input type="radio"/> V/f   <input type="radio"/> V/f w PG   <input checked="" type="radio"/> OLV   <input checked="" type="radio"/> CLV</p> <p><input type="radio"/> OLV/PM   <input type="radio"/> AOLV/PM   <input type="radio"/> CLV/PM</p> <p>Set to the motor iron saturation coefficient at 75% of magnetic flux for motor 2. This value is automatically set during Auto-Tuning.</p>	Default: 0.75 Min.: E4-07 Max.: 0.75	82
E4-09 (33F)	Motor 2 Mechanical Loss	<p><input type="radio"/> V/f   <input type="radio"/> V/f w PG   <input checked="" type="radio"/> OLV   <input checked="" type="radio"/> CLV</p> <p><input type="radio"/> OLV/PM   <input type="radio"/> AOLV/PM   <input type="radio"/> CLV/PM</p> <p>Sets the motor mechanical loss for motor 2 as a percentage of motor rated power (kW).</p>	Default: 0.0% Min.: 0.0 Max.: 10.0	82
E4-10 (340)	Motor 2 Iron Loss	<p><input checked="" type="radio"/> V/f   <input checked="" type="radio"/> V/f w PG   <input type="radio"/> OLV   <input type="radio"/> CLV</p> <p><input type="radio"/> OLV/PM   <input type="radio"/> AOLV/PM   <input type="radio"/> CLV/PM</p> <p>Sets the motor iron loss.</p>	Default: <1> Min.: 0 W Max.: 65535 W	82
E4-11 (327)	Motor 2 Rated Power	<p><input checked="" type="radio"/> V/f   <input checked="" type="radio"/> V/f w PG   <input checked="" type="radio"/> OLV   <input checked="" type="radio"/> CLV</p> <p><input type="radio"/> OLV/PM   <input type="radio"/> AOLV/PM   <input type="radio"/> CLV/PM</p> <p>Sets the motor rated capacity in kW. Automatically set during Auto-Tuning.</p>	Default: <1> Min.: 0.00 kW Max.: 650.00 kW	83

<1> Default setting is dependent on parameters C6-01, Drive Duty Selection, and o2-04, Drive Model Selection.

<2> The number of decimal places in the parameter value depends on the drive model and the ND/HD selection in parameter C6-01. This value has two decimal places (0.01 A) if the drive is set for a maximum applicable motor capacity up to and including 11 kW, and one decimal place (0.1 A) if the maximum applicable motor capacity is higher than 11 kW.

## A.8 F: Options

F parameters program the drive for PG feedback from the motor and to function with option cards.

### ◆ F1: PG Speed Control Card (PG-X3/PG-B3)

Parameters F1-01, F1-05, F1-06, F1-12, F1-13, and F1-18 through F1-21 include “PG 1” in the parameter name and are used to set up a PG option card plugged into option port CN5-C of the drive.

Parameters F1-21 through F1-37 include “PG 2” in the parameter name and are used to set up a PG option card plugged into option port CN5-B of the drive.

Other parameters in the F1 group are used to set operation for PG options plugged into port CN5-C and CN5-B.

No. (Addr. Hex)	Name	Description	Values	Page
F1-01 (380)	PG 1 Pulses Per Revolution	<div style="display: flex; justify-content: space-between; align-items: center;"> <span>V/f</span> <span><b>V/f w PG</b></span> <span>OLV</span> <span><b>CLV</b></span> </div> <div style="display: flex; justify-content: space-between; align-items: center;"> <span>OLV/PM</span> <span>AOLV/PM</span> <span><b>CLV/PM</b></span> </div> <p>Sets the number of PG (pulse generator or encoder) pulses. Sets the number of pulses per motor revolution.</p> <p><b>Note:</b> Setting range is 0 to 15000 ppr when A1-02 = 7 (CLV/PM control mode).</p>	Default: 1024 ppr Min.: 1 Max.: 60000	84
F1-02 (381)	Operation Selection at PG Open Circuit (PGo)	<div style="display: flex; justify-content: space-between; align-items: center;"> <span>V/f</span> <span><b>V/f w PG</b></span> <span>OLV</span> <span><b>CLV</b></span> </div> <div style="display: flex; justify-content: space-between; align-items: center;"> <span>OLV/PM</span> <span>AOLV/PM</span> <span><b>CLV/PM</b></span> </div> <p>0: Ramp to stop. Decelerate to stop using the deceleration time in C1-02. 1: Coast to stop. 2: Fast Stop. Decelerate to stop using the deceleration time in C1-09. 3: Alarm only. 4: No alarm display</p> <p><b>Note:</b> Due to potential damage to the motor and machinery, only use the “Alarm only” and “No alarm display” settings under special circumstances.</p>	Default: 1 Range: 0 to 4	84
F1-03 (382)	Operation Selection at Overspeed (oS)	<div style="display: flex; justify-content: space-between; align-items: center;"> <span>V/f</span> <span><b>V/f w PG</b></span> <span>OLV</span> <span><b>CLV</b></span> </div> <div style="display: flex; justify-content: space-between; align-items: center;"> <span>OLV/PM</span> <span>AOLV/PM</span> <span><b>CLV/PM</b></span> </div> <p>0: Ramp to stop. Decelerate to stop using the deceleration time in C1-02. 1: Coast to stop. 2: Fast Stop. Decelerate to stop using the deceleration time in C1-09. 3: Alarm only.</p>	Default: 1 Range: 0 to 3	84
F1-04 (383)	Operation Selection at Deviation	<div style="display: flex; justify-content: space-between; align-items: center;"> <span>V/f</span> <span><b>V/f w PG</b></span> <span>OLV</span> <span><b>CLV</b></span> </div> <div style="display: flex; justify-content: space-between; align-items: center;"> <span>OLV/PM</span> <span><b>AOLV/PM</b></span> <span><b>CLV/PM</b></span> </div> <p>0: Ramp to stop. Decelerate to stop using the deceleration time in C1-02. 1: Coast to stop. 2: Fast Stop. Decelerate to stop using the deceleration time in C1-09. 3: Alarm only.</p>	Default: 3 Range: 0 to 3	85
F1-05 (384)	PG 1 Rotation Selection	<div style="display: flex; justify-content: space-between; align-items: center;"> <span>V/f</span> <span><b>V/f w PG</b></span> <span>OLV</span> <span><b>CLV</b></span> </div> <div style="display: flex; justify-content: space-between; align-items: center;"> <span>OLV/PM</span> <span>AOLV/PM</span> <span><b>CLV/PM</b></span> </div> <p>0: Pulse A leads 1: Pulse B leads</p>	Default: </> Range: 0, 1	85
F1-06 (385)	PG 1 Division Rate for PG Pulse Monitor	<div style="display: flex; justify-content: space-between; align-items: center;"> <span>V/f</span> <span><b>V/f w PG</b></span> <span>OLV</span> <span><b>CLV</b></span> </div> <div style="display: flex; justify-content: space-between; align-items: center;"> <span>OLV/PM</span> <span>AOLV/PM</span> <span><b>CLV/PM</b></span> </div> <p>Sets the division ratio for the pulse monitor used of the PG option card installed to port CN5-C. By setting “xyz”, the division ratio becomes = [(1 + x) / yz]. If only using the A pulse for one-track input, the input ratio will be 1:1 regardless of F1-06 setting.</p>	Default: 1 Min.: 1 Max.: 132	85
F1-08 (387)	Overspeed Detection Level	<div style="display: flex; justify-content: space-between; align-items: center;"> <span>V/f</span> <span><b>V/f w PG</b></span> <span>OLV</span> <span><b>CLV</b></span> </div> <div style="display: flex; justify-content: space-between; align-items: center;"> <span>OLV/PM</span> <span><b>AOLV/PM</b></span> <span><b>CLV/PM</b></span> </div> <p>Sets the overspeed detection level as a percentage of the maximum output frequency.</p>	Default: 115% Min.: 0 Max.: 120	84



## A.8 F: Options

No. (Addr. Hex)	Name	Description	Values	Page
F1-09 (388)	Overspeed Detection Delay Time	<input type="checkbox"/> V/f <input checked="" type="checkbox"/> V/f w PG <input type="checkbox"/> OLV <input checked="" type="checkbox"/> CLV <input type="checkbox"/> OLV/PM <input checked="" type="checkbox"/> AOLV/PM <input checked="" type="checkbox"/> CLV/PM Sets the time in seconds for an overspeed situation to trigger a fault (oS).	Default: </> Min.: 0.0 s Max.: 2.0 s	84
F1-10 (389)	Excessive Speed Deviation Detection Level	<input type="checkbox"/> V/f <input checked="" type="checkbox"/> V/f w PG <input type="checkbox"/> OLV <input checked="" type="checkbox"/> CLV <input type="checkbox"/> OLV/PM <input checked="" type="checkbox"/> AOLV/PM <input checked="" type="checkbox"/> CLV/PM Sets the speed deviation detection level as a percentage of the maximum output frequency.	Default: 10% Min.: 0 Max.: 50	85
F1-11 (38A)	Excessive Speed Deviation Detection Delay Time	<input type="checkbox"/> V/f <input checked="" type="checkbox"/> V/f w PG <input type="checkbox"/> OLV <input checked="" type="checkbox"/> CLV <input type="checkbox"/> OLV/PM <input checked="" type="checkbox"/> AOLV/PM <input checked="" type="checkbox"/> CLV/PM Sets the time in seconds for a speed deviation situation to trigger a fault (dEv).	Default: 0.5 s Min.: 0.0 Max.: 10.0	85
F1-12 (38B)	PG 1 Gear Teeth 1	<input type="checkbox"/> V/f <input checked="" type="checkbox"/> V/f w PG <input type="checkbox"/> OLV <input type="checkbox"/> CLV <input type="checkbox"/> OLV/PM <input type="checkbox"/> AOLV/PM <input type="checkbox"/> CLV/PM Sets the gear ratio between the motor shaft and the encoder (PG). A gear ratio of 1 will be used if F1-12 or F1-13 are set to 0.	Default: 0 Min.: 0 Max.: 1000	85
F1-13 (38C)	PG 1 Gear Teeth 2	<input type="checkbox"/> V/f <input checked="" type="checkbox"/> V/f w PG <input type="checkbox"/> OLV <input type="checkbox"/> CLV <input type="checkbox"/> OLV/PM <input type="checkbox"/> AOLV/PM <input type="checkbox"/> CLV/PM Sets the gear ratio between the motor shaft and the encoder (PG). A gear ratio of 1 will be used if F1-12 or F1-13 are set to 0.	Default: 0 Min.: 0 Max.: 1000	85
F1-14 (38D)	PG Open-Circuit Detection Time	<input type="checkbox"/> V/f <input checked="" type="checkbox"/> V/f w PG <input type="checkbox"/> OLV <input checked="" type="checkbox"/> CLV <input type="checkbox"/> OLV/PM <input type="checkbox"/> AOLV/PM <input checked="" type="checkbox"/> CLV/PM Sets the time required to trigger a PG Open fault (PGo).	Default: 2.0 s Min.: 0.0 Max.: 10.0	84
F1-20 (3B4)	PG Option Card Disconnect Detection 1	<input type="checkbox"/> V/f <input checked="" type="checkbox"/> V/f w PG <input type="checkbox"/> OLV <input checked="" type="checkbox"/> CLV <input type="checkbox"/> OLV/PM <input type="checkbox"/> AOLV/PM <input checked="" type="checkbox"/> CLV/PM 0: Disabled 1: Enabled	Default: 1 Range: 0, 1	86
F1-21 (3BC)	PG 1 Signal Selection	<input type="checkbox"/> V/f <input checked="" type="checkbox"/> V/f w PG <input type="checkbox"/> OLV <input type="checkbox"/> CLV <input type="checkbox"/> OLV/PM <input type="checkbox"/> AOLV/PM <input type="checkbox"/> CLV/PM 0: A pulse detection 1: AB pulse detection	Default: 0 Range: 0, 1	86
F1-30 (3AA)	PG Card Option Port for Motor 2 Selection	<input type="checkbox"/> V/f <input checked="" type="checkbox"/> V/f w PG <input type="checkbox"/> OLV <input checked="" type="checkbox"/> CLV <input type="checkbox"/> OLV/PM <input type="checkbox"/> AOLV/PM <input type="checkbox"/> CLV/PM Sets the port for the PG option card used by motor 2. 0: CN5-C 1: CN5-B	Default: 1 Range: 0, 1	86
F1-31 (3B0)	PG 2 Pulses Per Revolution	<input type="checkbox"/> V/f <input checked="" type="checkbox"/> V/f w PG <input type="checkbox"/> OLV <input checked="" type="checkbox"/> CLV <input type="checkbox"/> OLV/PM <input type="checkbox"/> AOLV/PM <input type="checkbox"/> CLV/PM Sets the number of pulses for a PG option card connected to port CN5-B.	Default: 1024 ppr Min.: 1 Max.: 60000	84
F1-32 (3B1)	PG 2 Rotation Selection	<input type="checkbox"/> V/f <input checked="" type="checkbox"/> V/f w PG <input type="checkbox"/> OLV <input checked="" type="checkbox"/> CLV <input type="checkbox"/> OLV/PM <input type="checkbox"/> AOLV/PM <input type="checkbox"/> CLV/PM 0: Pulse A leads 1: Pulse B leads	Default: 0 Range: 0, 1	85
F1-33 (3B2)	PG 2 Gear Teeth 1	<input type="checkbox"/> V/f <input checked="" type="checkbox"/> V/f w PG <input type="checkbox"/> OLV <input type="checkbox"/> CLV <input type="checkbox"/> OLV/PM <input type="checkbox"/> AOLV/PM <input type="checkbox"/> CLV/PM Sets the gear ratio between the motor shaft and the encoder (PG). A gear ratio of 1 will be used if F1-33 or F1-34 are set to 0.	Default: 0 Min.: 0 Max.: 1000	85
F1-34 (3B3)	PG 2 Gear Teeth 2	<input type="checkbox"/> V/f <input checked="" type="checkbox"/> V/f w PG <input type="checkbox"/> OLV <input type="checkbox"/> CLV <input type="checkbox"/> OLV/PM <input type="checkbox"/> AOLV/PM <input type="checkbox"/> CLV/PM Sets the gear ratio between the motor shaft and the encoder (PG). A gear ratio of 1 will be used if F1-33 or F1-34 are set to 0.	Default: 0 Min.: 0 Max.: 1000	85
F1-35 (3BE)	PG 2 Division Rate for Pulse Monitor	<input type="checkbox"/> V/f <input checked="" type="checkbox"/> V/f w PG <input type="checkbox"/> OLV <input checked="" type="checkbox"/> CLV <input type="checkbox"/> OLV/PM <input type="checkbox"/> AOLV/PM <input type="checkbox"/> CLV/PM Sets the division ratio for the pulse monitor used of the PG option card 2 installed to port CN5-B. By setting "xyz", the division ratio becomes = [(1 + x) / yz].	Default: 1 Min.: 1 Max.: 132	85

No. (Addr. Hex)	Name	Description	Values	Page
F1-36 (3B5)	PG Option Card Disconnect Detection 2	<input type="radio"/> V/f <input checked="" type="radio"/> V/f w PG <input type="radio"/> OLV <input checked="" type="radio"/> CLV <input type="radio"/> OLV/PM <input type="radio"/> AOLV/PM <input type="radio"/> CLV/PM 0: Disabled 1: Enabled	Default: 1 Range: 0, 1	86
F1-37 (3BD)	PG 2 Signal Selection	<input type="radio"/> V/f <input checked="" type="radio"/> V/f w PG <input type="radio"/> OLV <input type="radio"/> CLV <input type="radio"/> OLV/PM <input type="radio"/> AOLV/PM <input type="radio"/> CLV/PM 0: A pulse detection 1: AB pulse detection	Default: 0 Range: 0, 1	86

<1> Default setting is determined by parameter A1-02, Control Method Selection.





## ◆ F2: Analog Input Card (AI-A3)

No. (Addr. Hex)	Name	Description	Values	Page
F2-01 (38F)	Analog Input Option Card Operation Selection	<input checked="" type="radio"/> All Modes 0: Option card input terminals V1, V2, and V3 replace drive input terminals A1, A2, and A3. 1: Input signals to terminals V1, V2, and V3 are added together to create the frequency reference.	Default: 0 Range: 0, 1	86
F2-02 (368) 	Analog Input Option Card Gain	<input checked="" type="radio"/> All Modes Sets the gain for the input signal to the analog card.	Default: 100.0% Min.: -999.9 Max.: 999.9	87
F2-03 (369) 	Analog Input Option Card Bias	<input checked="" type="radio"/> All Modes Sets the bias for the input signal to the analog card.	Default: 0.0% Min.: -999.9 Max.: 999.9	87

## ◆ F3: Digital Input Card (DI-A3)

No. (Addr. Hex)	Name	Description	Values	Page
F3-01 (390)	Digital Input Option Card Input Selection	<input checked="" type="radio"/> All Modes 0: BCD, 1% units 1: BCD, 0.1% units 2: BCD, 0.01% units 3: BCD, 1 Hz units 4: BCD, 0.1 Hz units 5: BCD, 0.01 Hz units 6: BCD customized setting (5-digit), 0.02 Hz units 7: Binary input When the digital operator units are set to be displayed in Hertz or user-set units (o1-03 = 2 or 3), the units for F3-01 are determined by parameter o1-03.	Default: 0 Range: 0 to 7	87
F3-03 (3B9)	Digital Input Option DI-A3 Data Length Selection	<input checked="" type="radio"/> All Modes 0: 8 bit 1: 12 bit 2: 16 bit	Default: 2 Range: 0 to 2	87

◆ F4: Analog Monitor Card (AO-A3)

No. (Addr. Hex)	Name	Description	Values	Page
F4-01 (391)	Terminal V1 Monitor Selection	<b>All Modes</b> Sets the monitor signal for output from terminal V1. Set this parameter to the last three digits of the desired U□-□□ monitor. Some U parameters are available only in certain control modes.	Default: 102 Range: 000 to 999	88
F4-02 (392) 	Terminal V1 Monitor Gain	<b>All Modes</b> Sets the gain for voltage output via terminal V1.	Default: 100.0% Min.: -999.9 Max.: 999.9	88
F4-03 (393)	Terminal V2 Monitor Selection	<b>All Modes</b> Sets the monitor signal for output from terminal V2. Set this parameter to the last three digits of the desired U□-□□ monitor. Some U parameters are available only in certain control modes.	Default: 103 Range: 000 to 999	88
F4-04 (394) 	Terminal V2 Monitor Gain	<b>All Modes</b> Sets the gain for voltage output via terminal V2.	Default: 50.0% Min.: -999.9 Max.: 999.9	88
F4-05 (395) 	Terminal V1 Monitor Bias	<b>All Modes</b> Sets the amount of bias added to the voltage output via terminal V1.	Default: 0.0% Min.: -999.9 Max.: 999.9	88
F4-06 (396) 	Terminal V2 Monitor Bias	<b>All Modes</b> Sets the amount of bias added to the voltage output via terminal V2.	Default: 0.0% Min.: -999.9 Max.: 999.9	88
F4-07 (397)	Terminal V1 Signal Level	<b>All Modes</b> 0: 0 to 10 V 1: -10 to 10 V	Default: 0 Range: 0, 1	88
F4-08 (398)	Terminal V2 Signal Level	<b>All Modes</b> 0: 0 to 10 V 1: -10 to 10 V	Default: 0 Range: 0, 1	88

◆ F5: Digital Output Card (DO-A3)

No. (Addr. Hex)	Name	Description	Values	Page
F5-01 (399)	Terminal P1-PC Output Selection	<b>All Modes</b> Sets the function for contact output terminals M1-M2, M3-M4, and photocoupler output terminals P1 through P6.	Default: 2 Range: 0 to 192	88
F5-02 (39A)	Terminal P2-PC Output Selection		Default: 4 Range: 0 to 192	88
F5-03 (39B)	Terminal P3-PC Output Selection		Default: 6 Range: 0 to 192	88
F5-04 (39C)	Terminal P4-PC Output Selection		Default: 37 Range: 0 to 192	88
F5-05 (39D)	Terminal P5-PC Output Selection		Default: F Range: 0 to 192	88
F5-06 (39E)	Terminal P6-PC Output Selection		Default: F Range: 0 to 192	88
F5-07 (39F)	Terminal M1-M2 Output Selection		Default: 0 Range: 0 to 192	88
F5-08 (3A0)	Terminal M3-M4 Output Selection		Default: 1 Range: 0 to 192	88
F5-09 (3A1)	DO-A3 Output Mode Selection	<b>All Modes</b> 0: Output terminals are each assigned separate output functions. 1: Binary code output. 2: Use output terminal functions selected by parameters F5-01 through F5-08.	Default: 0 Range: 0 to 2	89

## ◆ F6, F7: Communication Option Card

Parameters F6-01 through F6-03 and F6-06 through F6-08 are used for CC-Link, CANopen, DeviceNet, PROFIBUS-DP, and MECHATROLINK-II options. Other parameters in the F6 group are used for communication-protocol-specific settings. F7 parameters are used for EtherNet/IP, Modbus TCP/IP, and PROFINET options.

No. (Addr. Hex)	Name	Description	Values	Page
F6-01 (3A2)	Communications Error Operation Selection	<b>All Modes</b> 0: Ramp to stop. Decelerate to stop using the deceleration time in C1-02. 1: Coast to stop. 2: Fast Stop. Decelerate to stop using the deceleration time in C1-09. 3: Alarm only.	Default: 1 Range: 0 to 3	89
F6-02 (3A3)	External Fault from Comm. Option Detection Selection	<b>All Modes</b> 0: Always detected. 1: Detection during run only.	Default: 0 Range: 0, 1	89
F6-03 (3A4)	External Fault from Comm. Option Operation Selection	<b>All Modes</b> 0: Ramp to stop. Decelerate to stop using the deceleration time in C1-02. 1: Coast to stop. 2: Fast Stop. Decelerate to stop using the deceleration time in C1-09. 3: Alarm only.	Default: 1 Range: 0 to 3	89
F6-04 (3A5)	bUS Error Detection Time	<b>All Modes</b> Sets the delay time for error detection if a bus error occurs.	Default: 2.0 s Min.: 0.0 Max.: 5.0	90
F6-06 (3A7)	Torque Reference/Torque Limit Selection from Comm. Option	<input type="radio"/> V/f <input type="radio"/> V/f w PG <input type="radio"/> OLV <input checked="" type="radio"/> CLV <input type="radio"/> OLV/PM <input checked="" type="radio"/> AOLV/PM <input checked="" type="radio"/> CLV/PM 0: Disabled. Torque reference/limit from option board disabled. 1: Enabled. Torque reference/limit from option board enabled.	Default: 0 Range: 0, 1	90
F6-07 (3A8)	Multi-Step Speed Enable/Disable Selection when NefRef/ComRef is Selected	<b>All Modes</b> 0: Multi-step reference disabled (same as F7) 1: Multi-step reference enabled (same as V7)	Default: 0 Range: 0, 1	90
F6-08 (36A) <I>	Reset Communication Parameters	<b>All Modes</b> 0: Communication-related parameters (F6-□□) are not reset when the drive is initialized using A1-03. 1: Reset all communication-related parameters (F6-□□) when the drive is initialized using A1-03.	Default: 0 Range: 0, 1	90
F6-10 (3B6)	CC-Link Node Address	<b>All Modes</b> Sets the node address if a CC-Link option is installed.	Default: 0 Min.: 0 Max.: 64	90
F6-11 (3B7)	CC-Link Communication Speed	<b>All Modes</b> 0: 156 Kbps 1: 625 Kbps 2: 2.5 Mbps 3: 5 Mbps 4: 10 Mbps	Default: 0 Range: 0 to 4	91
F6-14 (3BB)	CC-Link bUS Error Auto Reset	<b>All Modes</b> 0: Disabled 1: Enabled	Default: 0 Range: 0, 1	91
F6-20 (36B)	MECHATROLINK Station Address	<b>All Modes</b> Sets the station address when the MECHATROLINK-II option has been installed.	Default: 21 Min.: 20 Max.: 3F	—
F6-21 (36C)	MECHATROLINK Frame Size	<b>All Modes</b> 0: 32 byte 1: 17 byte	Default: 0 Range: 0, 1	—
F6-22 (36D)	MECHATROLINK Link Speed	<b>All Modes</b> 0: 10 Mbps 1: 4 Mbps	Default: 0 Range: 0, 1	—
F6-23 (36E)	MECHATROLINK Monitor Selection (E)	<b>All Modes</b> Sets the MECHATROLINK-II monitor (E).	Default: 0 Min.: 0 Max.: FFFF	—

## A.8 F: Options

No. (Addr. Hex)	Name	Description	Values	Page
F6-24 (36F)	MECHATROLINK Monitor Selection (F)	<b>All Modes</b> Sets the MECHATROLINK-II monitor (F).	Default: 0 Min.: 0 Max.: FFFF	—
F6-25 (3C9)	Operation Selection at Watchdog Timer Error (E5)	<b>All Modes</b> 0: Ramp to stop. Decelerate using the deceleration time in C1-02. 1: Coast to stop 2: Fast stop. Decelerate using the deceleration time in C1-09. 3: Alarm only	Default: 1 Range: 0 to 3	—
F6-26 (3CA)	MECHATROLINK bUS Errors Detected	<b>All Modes</b> Sets the number of option communication errors (bUS).	Default: 2 Min.: 2 Max.: 10	—
F6-30 (3CB)	PROFIBUS-DP Node Address	<b>All Modes</b> Sets the node address.	Default: 0 Min.: 0 Max.: 125	91
F6-31 (3CC)	PROFIBUS-DP Clear Mode Selection	<b>All Modes</b> 0: Resets drive operation with a Clear mode command. 1: Maintains the previous operation state when Clear mode command is given.	Default: 0 Range: 0, 1	91
F6-32 (3CD)	PROFIBUS-DP Data Format Selection	<b>All Modes</b> 0: PPO Type 1: Conventional	Default: 0 Range: 0, 1	91
F6-35 (3D0)	CANopen Node ID Selection	<b>All Modes</b> Sets the node address.	Default: 0 Min.: 0 Max.: 126	91
F6-36 (3D1)	CANopen Communication Speed	<b>All Modes</b> 0: Auto-detection 1: 10 kbps 2: 20 kbps 3: 50 kbps 4: 125 kbps 5: 250 kbps 6: 500 kbps 7: 800 kbps 8: 1 Mbps	Default: 6 Range: 0 to 8	92
F6-50 (3C1)	DeviceNet MAC Address	<b>All Modes</b> Selects the drive MAC address.	Default: 64 Min.: 0 Max.: 64	92
F6-51 (3C2)	DeviceNet Communication Speed	<b>All Modes</b> 0: 125 kbps 1: 250 kbps 2: 500 kbps 3: Adjustable from network 4: Detect automatically	Default: 4 Range: 0 to 4	92
F6-52 (3C3)	DeviceNet PCA Setting	<b>All Modes</b> Sets the format of the data set from the DeviceNet master to the drive.	Default: 21 Min.: 0 Max.: 255	92
F6-53 (3C4)	DeviceNet PPA Setting	<b>All Modes</b> Sets the format of the data set from the drive to the DeviceNet master.	Default: 71 Min.: 0 Max.: 255	92
F6-54 (3C5)	DeviceNet Idle Mode Fault Detection	<b>All Modes</b> 0: Enabled 1: Disabled, no fault detection	Default: 0 Range: 0, 1	92
F6-55 (3C6)	DeviceNet Baud Rate Monitor	<b>All Modes</b> Verifies the baud rate running on the network. 0: 125 kbps 1: 250 kbps 2: 500 kbps	Default: 0 Range: 0 to 2	93
F6-56 (3D7)	DeviceNet Speed Scaling	<b>All Modes</b> Sets the scaling factor for the speed monitor in DeviceNet.	Default: 0 Min.: -15 Max.: 15	93



No. (Addr. Hex)	Name	Description	Values	Page
F6-57 (3D8)	DeviceNet Current Scaling	<b>All Modes</b> Sets the scaling factor for the output current monitor in DeviceNet.	Default: 0 Min.: -15 Max.: 15	93
F6-58 (3D9)	DeviceNet Torque Scaling	<b>All Modes</b> Sets the scaling factor for the torque monitor in DeviceNet.	Default: 0 Min.: -15 Max.: 15	93
F6-59 (3DA)	DeviceNet Power Scaling	<b>All Modes</b> Sets the scaling factor for the power monitor in DeviceNet.	Default: 0 Min.: -15 Max.: 15	93
F6-60 (3DB)	DeviceNet Voltage Scaling	<b>All Modes</b> Sets the scaling factor for the voltage monitor in DeviceNet.	Default: 0 Min.: -15 Max.: 15	93
F6-61 (3DC)	DeviceNet Time Scaling	<b>All Modes</b> Sets the scaling factor for the time monitor in DeviceNet.	Default: 0 Min.: -15 Max.: 15	93
F6-62 (3DD)	DeviceNet Heartbeat Interval	<b>All Modes</b> Sets the heartbeat interval for DeviceNet communications.	Default: 0 Min.: 0 Max.: 10	93
F6-63 (3DE)	DeviceNet Network MAC ID	<b>All Modes</b> Saves and monitors settings 0 to 63 of F6-50 (DeviceNet MAC Address).	Default: 63 Min.: 0 Max.: 63	93
F6-64 to F6-71 (3DF to 3C8)	Reserved	<b>All Modes</b> Reserved for Dynamic I/O Assembly Parameters.	–	–
F7-01 (3E5) <>	IP Address 1	<b>All Modes</b> Sets the most significant octet of network static IP address.	Default: 192 Range: 0 to 255	–
F7-02 (3E6) <>	IP Address 2	<b>All Modes</b> Sets the second most significant octet of network static IP address.	Default: 168 Range: 0 to 255	–
F7-03 (3E7) <>	IP Address 3	<b>All Modes</b> Sets the third most significant octet of network static IP address.	Default: 1 Range: 0 to 255	–
F7-04 (3E8) <>	IP Address 4	<b>All Modes</b> Sets the fourth most significant octet of network static IP address.	Default: 20 Range: 0 to 255	–
F7-05 (3E9)	Subnet Mask 1	<b>All Modes</b> Sets the most significant octet of network static Subnet Mask.	Default: 255 Range: 0 to 255	–
F7-06 (3EA)	Subnet Mask 2	<b>All Modes</b> Sets the second most significant octet of network static Subnet Mask.	Default: 255 Range: 0 to 255	–
F7-07 (3EB)	Subnet Mask 3	<b>All Modes</b> Sets the third most significant octet of network static Subnet Mask.	Default: 255 Range: 0 to 255	–
F7-08 (3EC)	Subnet Mask 4	<b>All Modes</b> Sets the fourth most significant octet of network static Subnet Mask.	Default: 0 Range: 0 to 255	–
F7-09 (3ED)	Gateway Address 1	<b>All Modes</b> Sets the most significant octet of network Gateway address.	Default: 192 Range: 0 to 255	–
F7-10 (3EE)	Gateway Address 2	<b>All Modes</b> Sets the second most significant octet of network Gateway address.	Default: 168 Range: 0 to 255	–
F7-11 (3EF)	Gateway Address 3	<b>All Modes</b> Sets the third most significant octet of network Gateway address.	Default: 1 Range: 0 to 255	–
F7-12 (3E0)	Gateway Address 4	<b>All Modes</b> Sets the fourth most significant octet of network Gateway address.	Default: 1 Range: 0 to 255	–

## A.8 F: Options

No. (Addr. Hex)	Name	Description	Values	Page
F7-13 (3F1)	Address Mode at Startup	<b>All Modes</b> Select the option address setting method 0: Static <3> 1: BOOTP 2: DHCP	Default: 2 Range: 0 to 2	–
F7-14 (3F2)	Duplex Mode Selection	<b>All Modes</b> Selects duplex mode setting. 0: Half duplex forced 1: Auto-negotiate duplex mode and communication speed 2: Full duplex forced	Default: 1 Range: 0 to 2	–
F7-15 (3F3)	Communication Speed Selection	<b>All Modes</b> Sets the communication speed 10: 10 Mbps 100: 100 Mbps	Default: 10 Range: 10, 100	–
F7-16 (3F4)	Communication Loss Timeout	<b>All Modes</b> Sets the timeout value for communication loss detection in tenths of a second. A value of 0 disables the connection timeout. Example: An entered value of 100 represents 10.0 seconds.	Default: 0 Min.: 0 Max.: 300	–
F7-17 (3F5)	EtherNet/IP Speed Scaling Factor	<b>All Modes</b> Sets the scaling factor for the speed monitor in EtherNet/IP Class ID 2AH Object.	Default: 0 Min.: -15 Max.: 15	–
F7-18 (3F6)	EtherNet/IP Current Scaling Factor	<b>All Modes</b> Sets the scaling factor for the output current monitor in EtherNet/IP Class ID 2AH Object.	Default: 0 Min.: -15 Max.: 15	–
F7-19 (3F7)	EtherNet/IP Torque Scaling Factor	<b>All Modes</b> Sets the scaling factor for the torque monitor in EtherNet/IP Class ID 2AH Object.	Default: 0 Min.: -15 Max.: 15	–
F7-20 (3F8)	EtherNet/IP Power Scaling Factor	<b>All Modes</b> Sets the scaling factor for the power monitor in EtherNet/IP Class ID 2AH Object.	Default: 0 Min.: -15 Max.: 15	–
F7-21 (3F9)	EtherNet/IP Voltage Scaling Factor	<b>All Modes</b> Sets the scaling factor for the voltage monitor in EtherNet/IP Class ID 2AH Object.	Default: 0 Min.: -15 Max.: 15	–
F7-22 (3FA)	EtherNet/IP Time Scaling	<b>All Modes</b> Sets the scaling factor for the time monitor in EtherNet/IP Class ID 2AH Object.	Default: 0 Min.: -15 Max.: 15	–
F7-23 to F7-32 (3FB to 374)	Dynamic Output Assembly Parameters	<b>All Modes</b> Parameters used in Output Assembly 116. Each parameter contains a MEMOBUS/Modbus address. The value received for Output Assembly 116 will be written to this corresponding MEMOBUS/Modbus address. A MEMOBUS/Modbus address value of 0 means that the value received for Output Assembly 116 will not be written to any MEMOBUS/Modbus register.	Default: 0	–
F7-33 to F7-42 (375 to 37E)	Dynamic Input Assembly Parameters	<b>All Modes</b> Parameters used in Input Assembly 166. Each parameter contains a MEMOBUS/Modbus address. The value sent for Input Assembly 166 will be read from this corresponding MEMOBUS/Modbus address. A MEMOBUS/Modbus address value of 0 means that the value sent for Input Assembly 166 is not defined by the user, therefore the option default register value will be returned.	Default: 0	–

<1> Parameter setting value is not reset to the default value when the drive is initialized.

<2> Cycle power for setting changes to take effect.

<3> If F7-13 is set to 0, all IP addresses (F7-01 to F7-04) must be unique.

## A.9 H Parameters: Multi-Function Terminals

H parameters assign functions to the multi-function input and output terminals.

### ◆ H1: Multi-Function Digital Inputs

No. (Addr. Hex)	Name	Description	Values	Page
H1-01 (438)	Multi-Function Digital Input Terminal S1 Function Selection	<b>All Modes</b> Assigns a function to the multi-function digital inputs. Refer to pages 267 to 271 for descriptions of setting values. <b>Note:</b> Set unused terminals to F.	Default: 40 (F) <1> Min.: 1 Max.: 9F	94
H1-02 (439)	Multi-Function Digital Input Terminal S2 Function Selection	<b>All Modes</b> Assigns a function to the multi-function digital inputs. Refer to pages 267 to 271 for descriptions of setting values. <b>Note:</b> Set unused terminals to F.	Default: 41 (F) <1> Min.: 1 Max.: 9F	94
H1-03 (400)	Multi-Function Digital Input Terminal S3 Function Selection	<b>All Modes</b> Assigns a function to the multi-function digital inputs. Refer to pages 267 to 271 for descriptions of setting values. <b>Note:</b> Set unused terminals to F.	Default: 24 Min.: 0 Max.: 9F	94
H1-04 (401)	Multi-Function Digital Input Terminal S4 Function Selection	<b>All Modes</b> Assigns a function to the multi-function digital inputs. Refer to pages 267 to 271 for descriptions of setting values. <b>Note:</b> Set unused terminals to F.	Default: 14 Min.: 0 Max.: 9F	94
H1-05 (402)	Multi-Function Digital Input Terminal S5 Function Selection	<b>All Modes</b> Assigns a function to the multi-function digital inputs. Refer to pages 267 to 271 for descriptions of setting values. <b>Note:</b> Set unused terminals to F.	Default: 3 (0) <1> Min.: 0 Max.: 9F	94
H1-06 (403)	Multi-Function Digital Input Terminal S6 Function Selection	<b>All Modes</b> Assigns a function to the multi-function digital inputs. Refer to pages 267 to 271 for descriptions of setting values. <b>Note:</b> Set unused terminals to F.	Default: 4 (3) <1> Min.: 0 Max.: 9F	94
H1-07 (404)	Multi-Function Digital Input Terminal S7 Function Selection	<b>All Modes</b> Assigns a function to the multi-function digital inputs. Refer to pages 267 to 271 for descriptions of setting values. <b>Note:</b> Set unused terminals to F.	Default: 6 (4) <1> Min.: 0 Max.: 9F	94
H1-08 (405)	Multi-Function Digital Input Terminal S8 Function Selection	<b>All Modes</b> Assigns a function to the multi-function digital inputs. Refer to pages 267 to 271 for descriptions of setting values. <b>Note:</b> Set unused terminals to F.	Default: 8 Min.: 0 Max.: 9F	94

<1> Value in parenthesis is the default setting when a 3-Wire initialization is performed (A1-03 = 3330).

H1 Multi-Function Digital Input Selections				
H1-□□ Setting	Function	Description	Page	
0	3-Wire sequence	<b>All Modes</b> Closed: Reverse rotation (only if the drive is set up for 3-Wire sequence) Terminals S1 and S2 are automatically set up for the Run command and Stop command.	95	
1	LOCAL/REMOTE selection	<b>All Modes</b> Open: REMOTE (parameter settings determine the source of the frequency Reference 1 or 2 (b1-01, b1-02 or b1-15, b1-16)) Closed: LOCAL, digital operator is run and reference source	95	
2	External reference 1/2 selection	<b>All Modes</b> Open: Run command and frequency reference source 1 (determined by b1-01 and b1-02) Closed: Run command and frequency reference source 2 (determined by b1-15 and b1-16)	96	

## A.9 H Parameters: Multi-Function Terminals

H1 Multi-Function Digital Input Selections			
H1-□□ Setting	Function	Description	Page
3	Multi-Step Speed Reference 1	<b>All Modes</b> When input terminals are set to Multi-Step Speed References 1 through 3, switching combinations of those terminals will create a multi-step speed sequence using the frequency references set in d1-01 through d1-08.	96
4	Multi-Step Speed Reference 2	<b>All Modes</b> When input terminals are set to Multi-Step Speed References 1 through 3, switching combinations of those terminals will create a multi-step speed sequence using the frequency references set in d1-01 through d1-08.	96
5	Multi-Step Speed Reference 3	<b>All Modes</b> When input terminals are set to Multi-Step Speed References 1 through 3, switching combinations of those terminals will create a multi-step speed sequence using the frequency references set in d1-01 through d1-08.	96
6	Jog reference selection	<b>All Modes</b> Closed: Jog frequency reference (d1-17) selected. Jog has priority over all other reference sources.	96
7	Accel/decel time selection 1	<b>All Modes</b> Used to switch between accel/decel time 1 (set in C1-01, C1-02) and accel/decel time 2 (set in C1-03, C1-04).	96
8	Baseblock command (N.O.)	<b>All Modes</b> Closed: No drive output	96
9	Baseblock command (N.C.)	<b>All Modes</b> Open: No drive output	96
A	Accel/decel ramp hold	<b>All Modes</b> Open: Accel/decel is not held Closed: The drive pauses during acceleration or deceleration and maintains the output frequency.	96
B	Drive overheat alarm (oH2)	<b>All Modes</b> Closed: Closes when an oH2 alarm occurs	97
C	Analog terminal input selection	<b>All Modes</b> Open: Function assigned by H3-14 is disabled. Closed: Function assigned by H3-14 is enabled.	97
D	PG encoder disable	<input type="radio"/> V/f <input checked="" type="radio"/> V/f w PG <input type="radio"/> OLV <input type="radio"/> CLV <input type="radio"/> OLV/PM <input type="radio"/> AOLV/PM <input type="radio"/> CLV/PM Open: Speed feedback for V/f Control with PG is enabled. Closed: Speed feedback disabled.	97
E	ASR integral reset	<input type="radio"/> V/f <input checked="" type="radio"/> V/f w PG <input type="radio"/> OLV <input checked="" type="radio"/> CLV <input type="radio"/> OLV/PM <input checked="" type="radio"/> AOLV/PM <input checked="" type="radio"/> CLV/PM Open: PI control Closed: Integral reset	97
F	Through mode	<b>All Modes</b> Select this setting when using the terminal in a pass-through mode. The terminal does not trigger a drive function but can be used as digital input for the controller the drive is connected to.	97
10	Up command	<b>All Modes</b> The drive accelerates when the Up command terminal closes, and decelerates when the Down command closes. When both terminals are closed or both are open, the drive holds the frequency reference. The Up and Down commands must always be used in conjunction with one another.	97
11	Down command	<b>All Modes</b> The drive accelerates when the Up command terminal closes, and decelerates when the Down command closes. When both terminals are closed or both are open, the drive holds the frequency reference. The Up and Down commands must always be used in conjunction with one another.	97
12	Forward Jog	<b>All Modes</b> Closed: Runs forward at the Jog frequency d1-17.	98

H1 Multi-Function Digital Input Selections			
H1-□□ Setting	Function	Description	Page
13	Reverse Jog	<b>All Modes</b> Closed: Runs reverse at the Jog frequency d1-17.	98
14	Fault reset	<b>All Modes</b> Closed: Resets faults if the cause is cleared and the Run command is removed.	98
15	Fast Stop (N.O.)	<b>All Modes</b> Closed: Decelerates at the Fast Stop time set to C1-09.	98
16	Motor 2 selection	<b>V/f</b> <b>V/f w PG</b> <b>OLV</b> <b>CLV</b> <b>OLV/PM</b> <b>AOLV/PM</b> <b>CLV/PM</b> Open: Motor 1 (E1-□□, E2-□□) Closed: Motor 2 (E3-□□, E4-□□)	99
17	Fast Stop (N.C.)	<b>All Modes</b> Open: Decelerates to stop at the Fast Stop time set to C1-09.	98
18	Timer function input	<b>All Modes</b> Triggers the timer set up by parameters b4-01 and b4-02. Must be set in conjunction with the timer function output (H2-□□ = 12).	99
19	PID disable	<b>All Modes</b> Open: PID control enabled Closed: PID control disabled	100
1A	Accel/decel time selection 2	<b>All Modes</b> Used in conjunction with an input terminal set for “Accel/decel time selection 1” (H1-□□ = 7), and allows the drive to switch between accel/decel times 3 and 4.	100
1B	Program lockout	<b>All Modes</b> Open: Parameters cannot be edited (except for U1-01 if the reference source is assigned to the digital operator). Closed: Parameters can be edited and saved.	100
1E	Reference sample hold	<b>All Modes</b> Closed: Samples the analog frequency reference and operates the drive at that speed.	100
20 to 2F	External fault	<b>All Modes</b> 20: N.O., Always detected, ramp to stop 21: N.C., Always detected, ramp to stop 22: N.O., During run, ramp to stop 23: N.C., During run, ramp to stop 24: N.O., Always detected, coast to stop 25: N.C., Always detected, coast to stop 26: N.O., During run, coast to stop 27: N.C., During run, coast to stop 28: N.O., Always detected, Fast Stop 29: N.C., Always detected, Fast Stop 2A: N.O., During run, Fast Stop 2B: N.C., During run, Fast Stop 2C: N.O., Always detected, alarm only (continue running) 2D: N.C., Always detected, alarm only (continue running) 2E: N.O., During run, alarm only (continue running) 2F: N.C., During run, alarm only (continue running)	100
30	PID integral reset	<b>All Modes</b> Closed: Resets the PID control integral value.	101
31	PID integral hold	<b>All Modes</b> Open: Performs integral operation. Closed: Maintains the current PID control integral value.	101
32	Multi-Step Speed Reference 4	<b>All Modes</b> Used in combination with input terminals set to Multi-Step Speed Reference 1, 2, and 3. Use parameters d1-09 to d1-16 to set reference values.	101
34	PID soft starter cancel	<b>All Modes</b> Open: PID soft starter is enabled. Closed: Disables the PID soft starter b5-17.	101

## A.9 H Parameters: Multi-Function Terminals

H1 Multi-Function Digital Input Selections			
H1-□□ Setting	Function	Description	Page
35	PID input level selection	<b>All Modes</b> Closed: Inverts the PID input signal.	101
40	Forward run command (2-Wire sequence)	<b>All Modes</b> Open: Stop Closed: Forward run <b>Note:</b> Cannot be set together with settings 42 or 43.	101
41	Reverse run command (2-Wire sequence)	<b>All Modes</b> Open: Stop Closed: Reverse run <b>Note:</b> Cannot be set together with settings 42 or 43.	101
42	Run command (2-Wire sequence 2)	<b>All Modes</b> Open: Stop Closed: Run <b>Note:</b> Cannot be set together with settings 40 or 41.	102
43	FWD/REV command (2-Wire sequence 2)	<b>All Modes</b> Open: Forward Closed: Reverse <b>Note:</b> Determines motor direction, but does not issue a Run command. Cannot be set together with settings 40 or 41.	102
44	Offset frequency 1	<b>All Modes</b> Closed: Adds d7-01 to the frequency reference.	102
45	Offset frequency 2	<b>All Modes</b> Closed: Adds d7-02 to the frequency reference.	102
46	Offset frequency 3	<b>All Modes</b> Closed: Adds d7-03 to the frequency reference.	102
47	Node setup	<b>All Modes</b> Closed: Node setup for SI-S3 enabled.	102
60	DC Injection Braking command	<b>V/f</b> <b>V/f w PG</b> <b>OLV</b> <b>CLV</b> <b>OLV/PM</b> <b>AOLV/PM</b> <b>CLV/PM</b> Closed: Triggers DC Injection Braking.	102
61	External Speed Search command 1	<b>V/f</b> <b>V/f w PG</b> <b>OLV</b> <b>CLV</b> <b>OLV/PM</b> <b>AOLV/PM</b> <b>CLV/PM</b> Closed: Activates Current Detection Speed Search from the maximum output frequency (E1-04).	102
62	External Speed Search command 2	<b>V/f</b> <b>V/f w PG</b> <b>OLV</b> <b>CLV</b> <b>OLV/PM</b> <b>AOLV/PM</b> <b>CLV/PM</b> Closed: Activates Current Detection Speed Search from the frequency reference.	102
63	Field weakening	<b>V/f</b> <b>V/f w PG</b> <b>OLV</b> <b>CLV</b> <b>OLV/PM</b> <b>AOLV/PM</b> <b>CLV/PM</b> Closed: The drive performs Field Weakening control as set for d6-01 and d6-02.	102
65	KEB Ride-Thru 1 (N.C.)	<b>All Modes</b> Open: KEB Ride-Thru 1 enabled.	102
66	KEB Ride-Thru 1 (N.O.)	<b>All Modes</b> Closed: KEB Ride-Thru 1 enabled.	102
67	Communications test mode	<b>All Modes</b> Tests the MEMOBUS/Modbus RS-485/422 interface. Displays “PASS” if the test completes successfully.	102
6A	Drive enable	<b>All Modes</b> Open: Drive disabled. If this input is opened during run, the drive will stop as specified by b1-03. Closed: Ready for operation.	103

H1 Multi-Function Digital Input Selections			
H1-□□ Setting	Function	Description	Page
71	Speed/Torque control Sswitch	<input type="radio"/> V/f <input type="radio"/> V/f w PG <input type="radio"/> OLV <input checked="" type="radio"/> CLV <input type="radio"/> OLV/PM <input type="radio"/> AOLV/PM <input checked="" type="radio"/> CLV/PM Open: Speed Control Closed: Torque Control	103
72	Zero servo	<input type="radio"/> V/f <input type="radio"/> V/f w PG <input type="radio"/> OLV <input checked="" type="radio"/> CLV <input type="radio"/> OLV/PM <input type="radio"/> AOLV/PM <input checked="" type="radio"/> CLV/PM Closed: Zero Servo enabled	103
75	Up 2 command	<input checked="" type="radio"/> All Modes Used to control the bias added to the frequency reference by the Up/Down 2 function. The Up 2 and Down 2 commands must always be used in conjunction with one another.	103
76	Down 2 command	<input checked="" type="radio"/> All Modes Used to control the bias added to the frequency reference by the Up/Down 2 function. The Up 2 and Down 2 commands must always be used in conjunction with one another.	103
77	ASR gain switch	<input type="radio"/> V/f <input type="radio"/> V/f w PG <input type="radio"/> OLV <input checked="" type="radio"/> CLV <input type="radio"/> OLV/PM <input checked="" type="radio"/> AOLV/PM <input checked="" type="radio"/> CLV/PM Open: ASR proportional gain 1 (C5-01) Closed: ASR proportional gain 2 (C5-03)	104
78	External torque reference polarity inversion	<input type="radio"/> V/f <input type="radio"/> V/f w PG <input type="radio"/> OLV <input checked="" type="radio"/> CLV <input type="radio"/> OLV/PM <input type="radio"/> AOLV/PM <input checked="" type="radio"/> CLV/PM Open: Forward torque reference. Closed: Reverse polarity.	104
7E	Forward/reverse detection (V/f Control with Simple PG feedback)	<input type="radio"/> V/f <input checked="" type="radio"/> V/f w PG <input type="radio"/> OLV <input type="radio"/> CLV <input type="radio"/> OLV/PM <input type="radio"/> AOLV/PM <input type="radio"/> CLV/PM Direction of rotation detection (for V/f with Simple PG Feedback)	104
90 to 97	DriveWorksEZ digital inputs 1 to 8	<input checked="" type="radio"/> All Modes Reserved for DWEZ input functions	104
9F	DriveWorksEZ disable	<input checked="" type="radio"/> All Modes Open: DWEZ enabled Closed: DWEZ disabled	104

◆ H2: Multi-Function Digital Outputs

No. (Addr. Hex)	Name	Description	Values	Page
H2-01 (40B)	Terminal M1-M2 function selection (relay)	<input checked="" type="radio"/> All Modes Refer to H2 Multi-Function Digital Output Settings on pages 272 to 274 for descriptions of setting values.	Default: 0 Range: 0 to 192	104
H2-02 (40C)	Terminal M3-M4 function selection (relay)		Default: 1 Range: 0 to 192	104
H2-03 (40D)	Terminal M5-M6 function selection (relay)		Default: 2 Range: 0 to 192	104
H2-06 (437)	Watt Hour Output Unit Selection	<input checked="" type="radio"/> All Modes Outputs a 200 ms pulse signal when the watt-hour counter increases by the units selected. 0: 0.1 kWh units 1: 1 kWh units 2: 10 kWh units 3: 100 kWh units 4: 1000 kWh units	Default: 0 Range: 0 to 4	114

## A.9 H Parameters: Multi-Function Terminals

H2 Multi-Function Digital Output Settings			
H2-□□ Setting	Function	Description	Page
0	During run	<b>All Modes</b> Closed: A Run command is active or voltage is output.	105
1	Zero speed	<b>All Modes</b> Open: Output frequency is above the minimum output frequency set in E1-09. Closed: Output frequency is below the minimum output frequency set in E1-09.	105
2	Speed agree 1	<b>All Modes</b> Closed: Output frequency equals the speed reference (plus or minus the hysteresis set to L4-02).	106
3	User-set speed agree 1	<b>All Modes</b> Closed: Output frequency and speed reference equal L4-01 (plus or minus the hysteresis set to L4-02).	106
4	Frequency detection 1	<b>All Modes</b> Closed: Output frequency is less than or equal to the value in L4-01 with hysteresis determined by L4-02.	107
5	Frequency detection 2	<b>All Modes</b> Closed: Output frequency is greater than or equal to the value in L4-01 with hysteresis determined by L4-02.	107
6	Drive ready	<b>All Modes</b> Closed: Power up is complete and the drive is ready to accept a Run command.	107
7	DC bus undervoltage	<b>All Modes</b> Closed: DC bus voltage is below the Uv trip level set in L2-05.	108
8	During baseblock (N.O.)	<b>All Modes</b> Closed: Drive has entered the baseblock state (no output voltage).	108
9	Frequency reference source	<b>All Modes</b> Open: External Reference 1 or 2 supplies the frequency reference (set in b1-01 or b1-15). Closed: Digital operator supplies the frequency reference.	108
A	Run command source	<b>All Modes</b> Open: External Reference 1 or 2 supplies the Run command (set in b1-02 or b1-16). Closed: Digital operator supplies the Run command.	108
B	Torque detection 1 (N.O.)	<b>All Modes</b> Closed: An overtorque or undertorque situation has been detected.	108
C	Frequency reference loss	<b>All Modes</b> Closed: Analog frequency reference has been lost.	108
E	Fault	<b>All Modes</b> Closed: Fault occurred.	108
F	Through mode	<b>All Modes</b> Set this value when using the terminal in the pass-through mode.	108
10	Minor fault	<b>All Modes</b> Closed: An alarm has been triggered, or the IGBTs have reached 90% of their expected life span.	109
11	Fault reset command active	<b>All Modes</b> Closed: A command has been entered to clear a fault via the input terminals or from the serial network.	109
12	Timer output	<b>All Modes</b> Closed: Timer output.	109
13	Speed agree 2	<b>All Modes</b> Closed: When drive output frequency equals the frequency reference $\pm$ L4-04.	109
14	User-set speed agree 2	<b>All Modes</b> Closed: When the drive output frequency is equal to the value in L4-03 $\pm$ L4-04.	109
15	Frequency detection 3	<b>All Modes</b> Closed: When the drive output frequency is less than or equal to the value in L4-03 $\pm$ L4-04.	110







H2 Multi-Function Digital Output Settings			
H2-□□ Setting	Function	Description	Page
16	Frequency detection 4	<b>All Modes</b> Closed: When the output frequency is greater than or equal to the value in L4-03 ±L4-04.	110
17	Torque detection 1 (N.C.)	<b>All Modes</b> Open: Overtorque or undertorque has been detected.	108
18	Torque detection 2 (N.O.)	<b>All Modes</b> Closed: Overtorque or undertorque has been detected.	
19	Torque detection 2 (N.C.)	<b>All Modes</b> Open: Overtorque or undertorque has been detected.	108
1A	During reverse	<b>All Modes</b> Closed: Drive is running in the reverse direction.	111
1B	During baseblock (N.C.)	<b>All Modes</b> Open: Drive has entered the baseblock state (no output voltage).	111
1C	Motor 2 selection	<b>V/f</b> <b>V/f w PG</b> <b>OLV</b> <b>CLV</b> <b>OLV/PM</b> <b>AOLV/PM</b> <b>CLV/PM</b> Closed: Motor 2 is selected by a digital input (H1-□□ = 16)	111
1D	During regeneration	<b>V/f</b> <b>V/f w PG</b> <b>OLV</b> <b>CLV</b> <b>OLV/PM</b> <b>AOLV/PM</b> <b>CLV/PM</b> Closed: Motor is regenerating energy into the drive.	111
1E	Restart enabled	<b>All Modes</b> Closed: An automatic restart is performed	111
1F	Motor overload alarm (oL1)	<b>All Modes</b> Closed: oL1 is at 90% of its trip point or greater. An oH3 situation also triggers this alarm.	112
20	Drive overheat pre-alarm (oH)	<b>All Modes</b> Closed: Heatsink temperature exceeds the parameter L8-02 value.	112
22	Mechanical weakening detection	<b>All Modes</b> Closed: Mechanical weakening detected.	112
2F	Maintenance period	<b>All Modes</b> Closed: Cooling fan, electrolytic capacitors, IGBTs, or the soft charge bypass relay may require maintenance.	112
30	During torque limit	<b>V/f</b> <b>V/f w PG</b> <b>OLV</b> <b>CLV</b> <b>OLV/PM</b> <b>AOLV/PM</b> <b>CLV/PM</b> Closed: When the torque limit has been reached.	112
31	During speed limit	<b>V/f</b> <b>V/f w PG</b> <b>OLV</b> <b>CLV</b> <b>OLV/PM</b> <b>AOLV/PM</b> <b>CLV/PM</b> Closed: Speed limit has been reached.	112
32	During speed limit in Torque Control	<b>V/f</b> <b>V/f w PG</b> <b>OLV</b> <b>CLV</b> <b>OLV/PM</b> <b>AOLV/PM</b> <b>CLV/PM</b> Closed: Speed limit has been reached while using Torque Control.	112
33	Zero Servo complete	<b>V/f</b> <b>V/f w PG</b> <b>OLV</b> <b>CLV</b> <b>OLV/PM</b> <b>AOLV/PM</b> <b>CLV/PM</b> Closed: Zero Servo operation has finished.	112
37	During frequency output	<b>All Modes</b> Open: Either the drive has stopped or baseblock, DC Injection Braking, or Initial Excitation is being performed. Closed: Drive is running the motor (not in a baseblock state and DC Injection is not being performed).	112
38	Drive enabled	<b>All Modes</b> Closed: Multi-function input set for “Drive enable” is closed (H1-□□ = 6A)	113
39	Watt hour pulse output	<b>All Modes</b> Output units are determined by H2-06. Outputs a pulse every 200 ms to indicate the kWh count.	113

## A.9 H Parameters: Multi-Function Terminals

H2 Multi-Function Digital Output Settings			
H2-□□ Setting	Function	Description	Page
3C	LOCAL/REMOTE status	<b>All Modes</b> Open: REMOTE Closed: LOCAL	113
3D	During speed search	<b>V/f</b> <b>V/f w PG</b> <b>OLV</b> <b>CLV</b> <b>OLV/PM</b> <b>AOLV/PM</b> <b>CLV/PM</b> Closed: Speed Search is being executed.	113
3E	PID feedback low	<b>All Modes</b> Closed: PID feedback level is too low.	113
3F	PID feedback high	<b>All Modes</b> Closed: The PID feedback level is too high.	113
4A	During KEB Ride-Thru	<b>All Modes</b> Closed: KEB Ride-Thru is being performed.	113
4C	During fast stop	<b>All Modes</b> Closed: A Fast Stop command has been entered from the operator or input terminals.	113
4D	oH Pre-alarm time limit	<b>All Modes</b> Closed: oH pre-alarm time limit has passed.	113
60	Internal cooling fan alarm	<b>All Modes</b> Closed: Internal cooling fan alarm	113
90 to 92	DriveWorksEZ digital outputs 1 to 3	<b>All Modes</b> Reserved for DWEZ digital output functions.	113
100 to 192	Function 0 to 92 with inverse output	<b>All Modes</b> Inverts the output switching of the multi-function output functions. Set the last two digits of 1□□ to reverse the output signal of that specific function.	113

## ◆ H3: Multi-Function Analog Inputs

No. (Addr. Hex)	Name	Description	Values	Page
H3-01 (410)	Terminal A1 Signal Level Selection	<b>All Modes</b> 0: 0 to 10 V 1: -10 to 10 V	Default: 0 Range: 0, 1	114
H3-02 (434)	Terminal A1 Function Selection	<b>All Modes</b> Sets the function of terminal A1.	Default: 0 Range: 0 to 31	114
H3-03 (411) 	Terminal A1 Gain Setting	<b>All Modes</b> Sets the level of the input value selected in H3-02 when 10 V is input at terminal A1.	Default: 100.0% Min.: -999.9 Max.: 999.9	114
H3-04 (412) 	Terminal A1 Bias Setting	<b>All Modes</b> Sets the level of the input value selected in H3-02 when 0 V is input at terminal A1.	Default: 0.0% Min.: -999.9 Max.: 999.9	114
H3-05 (413)	Terminal A3 Signal Level Selection	<b>All Modes</b> 0: 0 to 10 V 1: -10 to 10 V	Default: 0 Range: 0, 1	115
H3-06 (414)	Terminal A3 Function Selection	<b>All Modes</b> Sets the function of terminal A3.	Default: 2 Range: 0 to 31	115
H3-07 (415) 	Terminal A3 Gain Setting	<b>All Modes</b> Sets the level of the input value selected in H3-06 when 10 V is input at terminal A3.	Default: 100.0% Min.: -999.9 Max.: 999.9	116
H3-08 (416) 	Terminal A3 Bias Setting	<b>All Modes</b> Sets the level of the input value selected in H3-06 when 0 V is input at terminal A3.	Default: 0.0% Min.: -999.9 Max.: 999.9	116

No. (Addr. Hex)	Name	Description	Values	Page
H3-09 (417)	Terminal A2 Signal Level Selection	<p><b>All Modes</b></p> <p>0: 0 to 10 V 1: -10 to 10 V 2: 4 to 20 mA 3: 0 to 20 mA</p> <p><b>Note:</b> Use DIP switch S1 to set input terminal A2 for a current or a voltage input signal.</p>	Default: 2 Range: 0 to 3	116
H3-10 (418)	Terminal A2 Function Selection	<p><b>All Modes</b></p> <p>Sets the function of terminal A2.</p>	Default: 0 Range: 0 to 31	116
H3-11 (419)	Terminal A2 Gain Setting	<p><b>All Modes</b></p> <p>Sets the level of the input value selected in H3-10 when 10 V (20 mA) is input at terminal A2.</p>	Default: 100.0% Min.: -999.9 Max.: 999.9	116
H3-12 (41A)	Terminal A2 Bias Setting	<p><b>All Modes</b></p> <p>Sets the level of the input value selected in H3-10 when 0 V (0 or 4 mA) is input at terminal A2.</p>	Default: 0.0% Min.: -999.9 Max.: 999.9	116
H3-13 (41B)	Analog Input Filter Time Constant	<p><b>All Modes</b></p> <p>Sets a primary delay filter time constant for terminals A1, A2, and A3. Used for noise filtering.</p>	Default: 0.03 s Min.: 0.00 Max.: 2.00	116
H3-14 (41C)	Analog Input Terminal Enable Selection	<p><b>All Modes</b></p> <p>Determines which analog input terminals will be enabled when a digital input programmed for “Analog input enable” (H1-□□ = C) is activated.</p> <p>1: Terminal A1 only 2: Terminal A2 only 3: Terminals A1 and A2 only 4: Terminal A3 only 5: Terminals A1 and A3 6: Terminals A2 and A3 7: All terminals enabled</p>	Default: 7 Range: 1 to 7	117
H3-16 (2F0)	Terminal A1 Offset	<p><b>All Modes</b></p> <p>Adds an offset when the analog signal to terminal A1 is at 0 V.</p>	Default: 0 Min.: -500 Max.: 500	117
H3-17 (2F1)	Terminal A2 Offset	<p><b>All Modes</b></p> <p>Adds an offset when the analog signal to terminal A2 is at 0 V.</p>	Default: 0 Min.: -500 Max.: 500	117
H3-18 (2F2)	Terminal A3 Offset	<p><b>All Modes</b></p> <p>Adds an offset when the analog signal to terminal A3 is at 0 V.</p>	Default: 0 Min.: -500 Max.: 500	117

**H3 Multi-Function Analog Input Settings**

H3-□□ Setting	Function	Description	Page
0	Frequency bias	<p><b>All Modes</b></p> <p>10 V = E1-04 (maximum output frequency)</p>	117
1	Frequency gain	<p><b>All Modes</b></p> <p>0 to 10 V signal allows a setting of 0 to 100%. -10 to 0 V signal allows a setting of -100 to 0%.</p>	118
2	Auxiliary frequency reference 1 (used as a Multi-Step Speed 2)	<p><b>All Modes</b></p> <p>10 V = E1-04 (maximum output frequency)</p>	118
3	Auxiliary frequency reference 2 (3rd step analog)	<p><b>All Modes</b></p> <p>10 V = E1-04 (maximum output frequency)</p>	118
4	Output voltage bias	<p><b>V/f</b> <b>V/f w PG</b> <b>OLV</b> <b>CLV</b></p> <p><b>OLV/PM</b> <b>AOLV/PM</b> <b>CLV/PM</b></p> <p>10 V = E1-05 (motor rated voltage)</p>	118
5	Accel/decel time gain	<p><b>All Modes</b></p> <p>10 V = 100%</p>	118

## A.9 H Parameters: Multi-Function Terminals

H3 Multi-Function Analog Input Settings			
H3-□□ Setting	Function	Description	Page
6	DC Injection Braking current	<input checked="" type="radio"/> V/f <input checked="" type="radio"/> V/f w PG <input checked="" type="radio"/> OLV <input type="radio"/> CLV <input type="radio"/> OLV/PM <input type="radio"/> AOLV/PM <input type="radio"/> CLV/PM 10 V = Drive rated current	118
7	Overtorque/undertorque detection level	<input checked="" type="radio"/> All Modes 10 V = Drive rated current (V/f, V/f w PG) 10 V = Motor rated torque (OLV, CLV, OLV/PM, AOLV/PM, CLV/PM)	118
8	Stall Prevention level during run	<input checked="" type="radio"/> V/f <input checked="" type="radio"/> V/f w PG <input type="radio"/> OLV <input type="radio"/> CLV <input type="radio"/> OLV/PM <input type="radio"/> AOLV/PM <input type="radio"/> CLV/PM 10 V = Drive rated current	119
9	Output frequency lower limit level	<input checked="" type="radio"/> All Modes 10 V = E1-04 (maximum output frequency)	119
B	PID feedback	<input checked="" type="radio"/> All Modes 10 V = 100%	119
C	PID setpoint	<input checked="" type="radio"/> All Modes 10 V = 100%	119
D	Frequency bias	<input checked="" type="radio"/> All Modes 10 V = E1-04 (maximum output frequency)	119
E	Motor temperature (PTC input)	<input checked="" type="radio"/> All Modes 10 V = 100%	119
F	Through mode	<input checked="" type="radio"/> All Modes Set this value when using the terminal in the pass-through mode.	119
10	Forward torque limit	<input type="radio"/> V/f <input type="radio"/> V/f w PG <input checked="" type="radio"/> OLV <input checked="" type="radio"/> CLV <input type="radio"/> OLV/PM <input checked="" type="radio"/> AOLV/PM <input checked="" type="radio"/> CLV/PM 10 V = Motor rated torque	119
11	Reverse torque limit	<input type="radio"/> V/f <input type="radio"/> V/f w PG <input checked="" type="radio"/> OLV <input checked="" type="radio"/> CLV <input type="radio"/> OLV/PM <input checked="" type="radio"/> AOLV/PM <input checked="" type="radio"/> CLV/PM 10 V = Motor rated torque	119
12	Regenerative torque limit	<input type="radio"/> V/f <input type="radio"/> V/f w PG <input checked="" type="radio"/> OLV <input checked="" type="radio"/> CLV <input type="radio"/> OLV/PM <input checked="" type="radio"/> AOLV/PM <input checked="" type="radio"/> CLV/PM 10 V = Motor rated torque	119
13	Torque reference/Torque limit	<input type="radio"/> V/f <input type="radio"/> V/f w PG <input checked="" type="radio"/> OLV <input checked="" type="radio"/> CLV <input type="radio"/> OLV/PM <input checked="" type="radio"/> AOLV/PM <input checked="" type="radio"/> CLV/PM 10 V = Motor rated torque	119
14	Torque compensation	<input type="radio"/> V/f <input type="radio"/> V/f w PG <input checked="" type="radio"/> OLV <input checked="" type="radio"/> CLV <input type="radio"/> OLV/PM <input checked="" type="radio"/> AOLV/PM <input checked="" type="radio"/> CLV/PM 10 V = Motor rated torque	119
15	General torque limit	<input type="radio"/> V/f <input type="radio"/> V/f w PG <input checked="" type="radio"/> OLV <input checked="" type="radio"/> CLV <input type="radio"/> OLV/PM <input checked="" type="radio"/> AOLV/PM <input checked="" type="radio"/> CLV/PM 10 V = Motor rated torque	119
16	Differential PID feedback	<input checked="" type="radio"/> All Modes 10 V = 100%	119
17	Motor Thermistor (NTC)	<input checked="" type="radio"/> All Modes 10 V = -9 °C 0 V = 234 °C <b>Note:</b> This function is only available in models CIMR-A□4A0930, 4A1200 and A1000 HHP.	119
1F	Through mode	<input checked="" type="radio"/> All Modes Set this value when using the terminal in the pass-through mode.	119
30 to 32	DriveWorksEZ analog input 1 to 3	<input checked="" type="radio"/> All Modes Output is determined by the function selected using DWEZ.	119

◆ H4: Analog Outputs

No. (Addr. Hex)	Name	Description	Values	Page
H4-01 (41D)	Multi-Function Analog Output Terminal FM Monitor Selection	<b>All Modes</b> Selects the data to be output through multi-function analog output terminal FM. Set the desired monitor parameter to the digits available in U□-□□. For example, enter “103” for U1-03.	Default: 102 Range: 000 to 999	120
H4-02 (41E) ↔ RUN	Multi-Function Analog Output Terminal FM Gain	<b>All Modes</b> Sets the signal level at terminal FM that is equal to 100% of the selected monitor value.	Default: 100.0% Min.: -999.9 Max.: 999.9	120
H4-03 (41F) ↔ RUN	Multi-Function Analog Output Terminal FM Bias	<b>All Modes</b> Sets the signal level at terminal FM that is equal to 0% of the selected monitor value.	Default: 0.0% Min.: -999.9 Max.: 999.9	120
H4-04 (420)	Multi-Function Analog Output Terminal AM Monitor Selection	<b>All Modes</b> Selects the data to be output through multi-function analog output terminal AM. Set the desired monitor parameter to the digits available in U□-□□. For example, enter “103” for U1-03.	Default: 103 Range: 000 to 999	120
H4-05 (421) ↔ RUN	Multi-Function Analog Output Terminal AM Gain	<b>All Modes</b> Sets the signal level at terminal AM that is equal to 100% of the selected monitor value.	Default: 50.0% Min.: -999.9 Max.: 999.9	120
H4-06 (422) ↔ RUN	Multi-Function Analog Output Terminal AM Bias	<b>All Modes</b> Sets the signal level at terminal AM that is equal to 0% of the selected monitor value.	Default: 0.0% Min.: -999.9 Max.: 999.9	120
H4-07 (423)	Multi-Function Analog Output Terminal FM Signal Level Selection	<b>All Modes</b> 0: 0 to 10 V 1: -10 to 10 V 2: 4 to 20 mA	Default: 0 Range: 0 to 2	121
H4-08 (424)	Multi-Function Analog Output Terminal AM Signal Level Selection	<b>All Modes</b> 0: 0 to 10 V 1: -10 to 10 V 2: 4 to 20 mA	Default: 0 Range: 0 to 2	121

◆ H5: MEMOBUS/Modbus Serial Communication





No. (Addr. Hex)	Name	Description	Values	Page
H5-01 (425) </>	Drive Node Address	<b>All Modes</b> Selects drive station node number (address) for MEMOBUS/Modbus terminals R+, R-, S+, S-. Cycle power for the setting to take effect.	Default: 1F (Hex) Min.: 0 Max.: FF	121
H5-02 (426)	Communication Speed Selection	<b>All Modes</b> 0: 1200 bps 1: 2400 bps 2: 4800 bps 3: 9600 bps 4: 19200 bps 5: 38400 bps 6: 57600 bps 7: 76800 bps 8: 115200 bps Cycle power for the setting to take effect.	Default: 3 Range: 0 to 8	121
H5-03 (427)	Communication Parity Selection	<b>All Modes</b> 0: No parity 1: Even parity 2: Odd parity Cycle power for the setting to take effect.	Default: 0 Range: 0 to 2	122



## A.9 H Parameters: Multi-Function Terminals

No. (Addr. Hex)	Name	Description	Values	Page
H5-04 (428)	Stopping Method after Communication Error (CE)	<b>All Modes</b> 0: Ramp to stop 1: Coast to stop 2: Fast Stop 3: Alarm only	Default: 0 Range: 0 to 3	122
H5-05 (429)	Communication Fault Detection Selection	<b>All Modes</b> 0: Disabled 1: Enabled. If communication is lost for more than two seconds, a CE fault will occur.	Default: 0 Range: 0, 1	122
H5-06 (42A)	Drive Transmit Wait Time	<b>All Modes</b> Set the wait time between receiving and sending data.	Default: 5 ms Min.: 5 Max.: 65	122
H5-07 (42B)	RTS Control Selection	<b>All Modes</b> 0: Disabled. RTS is always on. 1: Enabled. RTS turns on only when sending.	Default: 1 Range: 0, 1	122
H5-09 (435)	CE Detection Time	<b>All Modes</b> Sets the time required to detect a communications error. Adjustment may be needed when networking several drives.	Default: 2.0 s Min.: 0.0 Max.: 10.0	123
H5-10 (436)	Unit Selection for MEMOBUS/Modbus Register 0025H	<b>All Modes</b> 0: 0.1 V units 1: 1 V units	Default: 0 Range: 0, 1	123
H5-11 (43C)	Communications ENTER Function Selection	<b>All Modes</b> 0: Drive requires an Enter command before accepting any changes to parameter settings. 1: Parameter changes are activated immediately without the Enter command (same as V7).	Default: 1 Range: 0, 1	123
H5-12 (43D)	Run Command Method Selection	<b>All Modes</b> 0: FWD/Stop, REV/Stop 1: Run/Stop, FWD/REV	Default: 0 Range: 0, 1	123

<1> If this parameter is set to 0, the drive will be unable to respond to MEMOBUS/Modbus commands.

## ◆ H6: Pulse Train Input/Output

No. (Addr. Hex)	Name	Description	Values	Page
H6-01 (42C)	Pulse Train Input Terminal RP Function Selection	<b>All Modes</b> 0: Frequency reference 1: PID feedback value 2: PID setpoint value 3: V/f Control with Simple PG feedback (possible only when using motor 1 in V/f Control)	Default: 0 Range: 0 to 3	124
H6-02 (42D) 	Pulse Train Input Scaling	<b>All Modes</b> Sets the terminal RP input signal frequency that is equal to 100% of the value selected in H6-01.	Default: 1440 Hz Min.: 1000 Max.: 32000	125
H6-03 (42E) 	Pulse Train Input Gain	<b>All Modes</b> Sets the level of the value selected in H6-01 when a frequency with the value set in H6-02 is input.	Default: 100.0% Min.: 0.0 Max.: 1000.0	125
H6-04 (42F) 	Pulse Train Input Bias	<b>All Modes</b> Sets the level of the value selected in H6-01 when 0 Hz is input.	Default: 0.0% Min.: -100.0 Max.: 100.0	125
H6-05 (430) 	Pulse Train Input Filter Time	<b>All Modes</b> Sets the pulse train input filter time constant.	Default: 0.10 s Min.: 0.00 Max.: 2.00	125

No. (Addr. Hex)	Name	Description	Values	Page
H6-06 (431) 	Pulse Train Monitor Selection	<b>All Modes</b> Select the pulse train monitor output function (value of the □-□□ part of U□-□□). For example, enter “501” for U5-01.	Default: 102 Range: 000 to 809	125
H6-07 (432) 	Pulse Train Monitor Scaling	<b>All Modes</b> Sets the terminal MP output signal frequency when the monitor value is 100%. To have the pulse train monitor output equal the output frequency, set H6-06 to 2 and H6-07 to 0.	Default: 1440 Hz Min.: 0 Max.: 32000	125
H6-08 (43F)	Pulse Train Input Minimum Frequency	<b>All Modes</b> Sets the minimum frequency for the pulse train input to be detected. Enabled when H6-01 = 0, 1, or 2.	Default: 0.5 Hz Min.: 0.1 Max.: 1000.0	125

## A.10 L: Protection Function

L parameters provide protection to the drive and motor, including control during momentary power loss, Stall Prevention, frequency detection, fault restarts, overtorque detection, torque limits, and other types of hardware protection.

### ◆ L1: Motor Protection

No. (Addr. Hex)	Name	Description	Values	Page
L1-01 (480)	Motor Overload Protection Selection	<p><b>All Modes</b></p> <p>0: Disabled                      1: General purpose motor (standard fan cooled)                      2: Drive dedicated motor with a speed range of 1:10                      3: Vector motor with a speed range of 1:100                      4: PM motor with variable torque                      5: PM motor with constant torque control                      6: General purpose motor (50 Hz)</p> <p>The drive may not be able to provide protection when using multiple motors, even if overload is enabled in L1-01. Set L1-01 to 0 and install separate thermal relays to each motor.</p>	Default: <I> Range: 0 to 6	126
L1-02 (481)	Motor Overload Protection Time	<p><b>All Modes</b></p> <p>Sets the motor thermal overload protection (oL1) time.</p>	Default: 1.0 min Min.: 0.1 Max.: 5.0	128
L1-03 (482)	Motor Overheat Alarm Operation Selection (PTC input)	<p><b>All Modes</b></p> <p>Sets operation when the motor temperature analog input (H3-02, H3-06, or H3-10 = E) exceeds the oH3 alarm level.</p> <p>0: Ramp to stop                      1: Coast to stop                      2: Fast Stop (decelerate to stop using the deceleration time in C1-09)                      3: Alarm only ("oH3" will flash)</p>	Default: 3 Range: 0 to 3	129
L1-04 (483)	Motor Overheat Fault Operation Selection (PTC input)	<p><b>All Modes</b></p> <p>Sets stopping method when the motor temperature analog input (H3-02, H3-06, or H3-10 = E) exceeds the oH4 fault level.</p> <p>0: Ramp to stop                      1: Coast to stop                      2: Fast Stop (decelerate to stop using the deceleration time in C1-09)</p>	Default: 1 Range: 0 to 2	129
L1-05 (484)	Motor Temperature Input Filter Time (PTC input)	<p><b>All Modes</b></p> <p>Adjusts the filter for the motor temperature analog input (H3-02, H3-06, or H3-10 = E).</p>	Default: 0.20 s Min.: 0.00 Max.: 10.00	129
L1-13 (46D)	Continuous Electrothermal Operation Selection	<p><b>All Modes</b></p> <p>0: Disabled                      1: Enabled</p>	Default: 1 Range: 0, 1	129
L1-15 (440)	Motor 1 Thermistor Selection (NTC)	<p><b>All Modes</b></p> <p>Sets the input selection for Motor #1 Thermistor.</p> <p>0: Disabled                      1: Thermistor input by Analog Input                      2: Thermistor input by special Thermistor Input</p>	Default: 0 Range: 0 to 2	130
L1-16 (441)	Motor 1 Overheat Temperature	<p><b>All Modes</b></p> <p>Sets the range of the Motor #1 oH5 trip level.</p>	Default: 120 °C Min.: 50 Max.: 200	131
L1-17 (442)	Motor 2 Thermistor Selection (NTC)	<p><b>All Modes</b></p> <p>Sets the input selection for Motor #2 Thermistor.</p> <p>0: Disabled                      1: Thermistor input by Analog Input                      2: Thermistor input by special Thermistor Input</p>	Default: 0 Range: 0 to 2	131
L1-18 (443)	Motor 2 Overheat Temperature	<p><b>All Modes</b></p> <p>Sets the range of the Motor #2 oH5 trip level.</p>	Default: 120 °C Min.: 50 Max.: 200	131



No. (Addr. Hex)	Name	Description	Values	Page
L1-19 (444)	Operation at Thermistor Disconnect (THo) (NTC)	<b>All Modes</b> Sets the action for when a thermistor open circuit is detected. 0: Ramp stop 1: Coast stop 2: Fast Stop (decelerate to stop using the deceleration time set to C1-09) 3: Alarm, Continue Running	Default: 3 Range: 0 to 3	131
L1-20 (445)	Operation at Motor Overheat (oH5)	<b>All Modes</b> Sets the action for when a oH5 is detected in either Motor #1 or Motor #2. 0: Ramp stop 1: Coast stop 2: Fast Stop (decelerate to stop using the deceleration time set to C1-09) 3: Alarm, Continue Running	Default: 1 Range: 0 to 3	131
L1-21 (73A)	Thermally sensitive resistor selection	<b>All Modes</b> Sets the type of thermistor input for Motor #1 and Motor #2: either NTC or Pt100. 0: H5 table selection 1: Pt100 table selection	Default: 0 Range: 0,1	132

<1> Default setting is determined by parameter A1-02, Control Method Selection.

## ◆ L2: Momentary Power Loss Ride-Thru

No. (Addr. Hex)	Name	Description	Values	Page
L2-01 (485)	Momentary Power Loss Operation Selection	<b>All Modes</b> 0: Disabled. Drive trips on Uv1 fault when power is lost. 1: Recover within the time set in L2-02. Uv1 will be detected if power loss is longer than L2-02. 2: Recover as long as CPU has power. Uv1 is not detected. 3: KEB deceleration for the time set to L2-02. 4: KEB deceleration as long as CPU has power. 5: KEB deceleration to stop.	Default: 0 Range: 0 to 5	132
L2-02 (486)	Momentary Power Loss Ride-Thru Time	<b>All Modes</b> Sets the Power Loss Ride-Thru time. Enabled only when L2-01 = 1 or 3.	Default: </> Min.: 0.0 s Max.: 25.5 s	137
L2-03 (487)	Momentary Power Loss Minimum Baseblock Time	<b>All Modes</b> Sets the minimum wait time for residual motor voltage decay before the drive output reenergizes after performing Power Loss Ride-Thru. Increasing the time set to L2-03 may help if overcurrent or overvoltage occur during Speed Search or during DC Injection Braking.	Default: </> Min.: 0.1 s Max.: 5.0 s	137
L2-04 (488)	Momentary Power Loss Voltage Recovery Ramp Time	<b>V/f</b> <b>V/f w PG</b> <b>OLV</b> <b>CLV</b> <b>OLV/PM</b> <b>AOLV/PM</b> <b>CLV/PM</b> Sets the time for the output voltage to return to the preset V/f pattern during Speed Search.	Default: </> Min.: 0.0 s Max.: 5.0 s	138
L2-05 (489)	Undervoltage Detection Level (Uv1)	<b>All Modes</b> Sets the DC bus undervoltage trip level.	Default: 400 Vdc </> </> Min.: 300 Vdc Max.: 420 Vdc </>	138
L2-07 (48B)	KEB Acceleration Time	<b>All Modes</b> Sets the time to accelerate to the frequency reference when momentary power loss is over. If set to 0.0, the active acceleration time is used.	Default: 0.00 s Min.: 0.00 Max.: 6000.0 </>	138
L2-10 (48E)	KEB Detection Time (Minimum KEB Time)	<b>All Modes</b> Sets the time to perform KEB Ride-Thru.	Default: 50 ms Min.: 0 Max.: 2000	138
L2-11 (461)	DC Bus Voltage Setpoint during KEB	<b>All Modes</b> Sets the desired value of the DC bus voltage during KEB Ride-Thru.	Default: </> [E1-01] × 1.22 Min.: 300 Vdc Max.: 800 Vdc </>	138

<1> Default setting is dependent on parameters C6-01, Drive Duty Selection, and o2-04, Drive Model Selection.

## A.10 L: Protection Function

- <2> Default setting is dependent on parameter E1-01, Input voltage Setting.
- <3> Values shown are specific to 400 V class drives. Multiply the value by 1.4375 for 575 V class drives. Multiply the value by 1.725 for 690 V class drives.
- <4> Setting range value is dependent on parameter C1-10, Accel/Decel Time Setting Units. When C1-10 = 0 (units of 0.01 seconds), the setting range becomes 0.00 to 600.00 seconds.
- <5> Values shown are specific to 400 V class drives. Multiply the value by 1.4375 for 575 V class drives. Multiply the value by 1.725 for 690 V class drives.

### ◆ L3: Stall Prevention

No. (Addr. Hex)	Name	Description	Values	Page
L3-01 (48F)	Stall Prevention Selection during Acceleration	<p><b>V/f</b> <b>V/f w PG</b> <b>OLV</b> <input type="radio"/> <b>CLV</b></p> <p><b>OLV/PM</b> <input type="radio"/> <b>AOLV/PM</b> <input type="radio"/> <b>CLV/PM</b></p> <p>0: Disabled.            1: General purpose. Acceleration is paused as long as the current is above the L3-02 setting.            2: Intelligent. Accelerate in the shortest possible time without exceeding the L3-02 level.</p> <p><b>Note:</b> Setting 2 is not available when using OLV/PM.</p>	Default: 1 Range: 0 to 2	139
L3-02 (490)	Stall Prevention Level during Acceleration	<p><b>V/f</b> <b>V/f w PG</b> <b>OLV</b> <input type="radio"/> <b>CLV</b></p> <p><b>OLV/PM</b> <input type="radio"/> <b>AOLV/PM</b> <input type="radio"/> <b>CLV/PM</b></p> <p>Used when L3-01 = 1 or 2. 100% is equal to the drive rated current.</p>	Default: <1> Min.: 0% Max.: 150% <1>	140
L3-03 (491)	Stall Prevention Limit during Acceleration	<p><b>V/f</b> <b>V/f w PG</b> <b>OLV</b> <input type="radio"/> <b>CLV</b></p> <p><b>OLV/PM</b> <input type="radio"/> <b>AOLV/PM</b> <input type="radio"/> <b>CLV/PM</b></p> <p>Sets Stall Prevention lower limit during acceleration when operating in the constant power range. Set as a percentage of drive rated current.</p>	Default: 50% Min.: 0 Max.: 100	140
L3-04 (492)	Stall Prevention Selection during Deceleration	<p><b>All Modes</b></p> <p>0: Disabled. Deceleration at the active deceleration rate. An ov fault may occur.            1: General purpose. Deceleration is paused when the DC bus voltage exceeds the Stall Prevention level.            2: Intelligent. Decelerate as fast as possible while avoiding ov faults.            3: Stall Prevention with braking resistor. Stall Prevention during deceleration is enabled in coordination with dynamic braking.            4: Overexcitation Deceleration. Decelerates while increasing the motor flux.            5: Overexcitation Deceleration 2. Adjust the deceleration rate according to the DC bus voltage.</p> <p><b>Note:</b> Setting 3 is not available in models CIMR-A□4A0930 and 4A1200. A1000 HHP models only have settings 0, 1, 4, and 5.</p>	Default: 1 Range: 0 to 5 <2>	141
L3-05 (493)	Stall Prevention Selection during Run	<p><b>V/f</b> <b>V/f w PG</b> <input type="radio"/> <b>OLV</b> <input type="radio"/> <b>CLV</b></p> <p><b>OLV/PM</b> <input type="radio"/> <b>AOLV/PM</b> <input type="radio"/> <b>CLV/PM</b></p> <p>0: Disabled. Drive runs at a set frequency. A heavy load may cause speed loss.            1: Decel time 1. Uses the deceleration time set to C1-02 while Stall Prevention is performed.            2: Decel time 2. Uses the deceleration time set to C1-04 while Stall Prevention is performed.</p>	Default: 1 Range: 0 to 2	142
L3-06 (494)	Stall Prevention Level during Run	<p><b>V/f</b> <b>V/f w PG</b> <input type="radio"/> <b>OLV</b> <input type="radio"/> <b>CLV</b></p> <p><b>OLV/PM</b> <input type="radio"/> <b>AOLV/PM</b> <input type="radio"/> <b>CLV/PM</b></p> <p>Enabled when L3-05 is set to 1 or 2. 100% is equal to the drive rated current.</p>	Default: <1> Min.: 30% Max.: 150% <1>	142
L3-11 (4C7)	Overvoltage Suppression Function Selection	<p><b>All Modes</b></p> <p>Enables or disables the ov suppression function, which allows the drive to change the output frequency as the load changes to prevent an ov fault.</p> <p>0: Disabled            1: Enabled</p>	Default: 0 Range: 0, 1	143
L3-17 (462)	Target DC Bus Voltage for Overvoltage Suppression and Stall Prevention	<p><b>All Modes</b></p> <p>Sets the desired value for the DC bus voltage during overvoltage suppression and Stall Prevention during deceleration.</p>	Default: 370 Vdc <3> <8> Min.: 150 Max.: 400 <8>	143

No. (Addr. Hex)	Name	Description	Values	Page
L3-22 (4F9)	Deceleration Time at Stall Prevention during Acceleration	<div style="display: flex; justify-content: space-between; align-items: center;"> <span>V/f</span> <span>V/f w PG</span> <span>OLV</span> <span>CLV</span> </div> <div style="display: flex; justify-content: space-between; align-items: center; margin-top: 5px;"> <span><b>OLV/PM</b></span> <span>AOLV/PM</span> <span>CLV/PM</span> </div> <p>Sets the deceleration time used for Stall Prevention during acceleration in OLV/PM.</p>	Default: 0.0 s Min.: 0.0 Max.: 6000	<a href="#">140</a>
L3-23 (4FD)	Automatic Reduction Selection for Stall Prevention during Run	<div style="display: flex; justify-content: space-between; align-items: center;"> <span><b>V/f</b></span> <span>V/f w PG</span> <span>OLV</span> <span>CLV</span> </div> <div style="display: flex; justify-content: space-between; align-items: center; margin-top: 5px;"> <span>OLV/PM</span> <span>AOLV/PM</span> <span>CLV/PM</span> </div> <p>0: Sets the Stall Prevention level set in L3-04 that is used throughout the entire frequency range. 1: Automatic Stall Prevention level reduction in the constant output range. The lower limit value is 40% of L3-06.</p>	Default: 0 Range: 0, 1	<a href="#">142</a>
L3-27 (456)	Stall Prevention Detection Time	<div style="display: flex; justify-content: space-between; align-items: center;"> <span>V/f</span> <span>V/f w PG</span> <span><b>OLV</b></span> <span>CLV</span> </div> <div style="display: flex; justify-content: space-between; align-items: center; margin-top: 5px;"> <span><b>OLV/PM</b></span> <span>AOLV/PM</span> <span>CLV/PM</span> </div> <p>Sets the time the current must exceed the Stall Prevention level to activate Stall Prevention.</p>	Default: 50 ms Min.: 0 Max.: 5000	<a href="#">143</a>

- <1> Upper limit is dependent on parameters C6-01, Drive Duty Selection, and L8-38, Frequency Reduction Selection.
- <2> The setting range is 0 to 2 in OLV/PM control mode. The setting range is 0 and 1 in CLV or AOLV/PM control modes.
- <3> Default setting is dependent on parameter E1-01, Input voltage Setting.
- <8> Values shown are specific to 400 V class drives. Multiply the value by 1.4375 for 575 V class drives. Multiply the value by 1.725 for 690 V class drives.

### ◆ L4: Speed Detection

No. (Addr. Hex)	Name	Description	Values	Page
L4-01 (499)	Speed Agreement Detection Level	<div style="display: flex; justify-content: space-between; align-items: center;"> <span><b>All Modes</b></span> </div> <p>L4-01 sets the frequency detection level for digital output functions H2-□□ = 2, 3, 4, 5.</p>	Default: 0.0 Hz Min.: 0.0 Max.: 150.0	<a href="#">143</a>
L4-02 (49A)	Speed Agreement Detection Width	<div style="display: flex; justify-content: space-between; align-items: center;"> <span><b>All Modes</b></span> </div> <p>L4-02 sets the hysteresis or allowable margin for speed detection.</p>	Default: <1> Min.: 0.0 Max.: 20.0	<a href="#">143</a>
L4-03 (49B)	Speed Agreement Detection Level (+/-)	<div style="display: flex; justify-content: space-between; align-items: center;"> <span><b>All Modes</b></span> </div> <p>L4-03 sets the frequency detection level for digital output functions H2-□□ = 13, 14, 15, 16.</p>	Default: 0.0 Hz Min.: -150.0 Max.: 150.0	<a href="#">144</a>
L4-04 (49C)	Speed Agreement Detection Width (+/-)	<div style="display: flex; justify-content: space-between; align-items: center;"> <span><b>All Modes</b></span> </div> <p>L4-04 sets the hysteresis or allowable margin for speed detection.</p>	Default: <1> Min.: 0.0 Max.: 20.0	<a href="#">144</a>
L4-05 (49D)	Frequency Reference Loss Detection Selection	<div style="display: flex; justify-content: space-between; align-items: center;"> <span><b>All Modes</b></span> </div> <p>0: Stop. Drive stops when the frequency reference is lost. 1: Run. Drive runs at a reduced speed when the frequency reference is lost.</p>	Default: 0 Range: 0, 1	<a href="#">144</a>
L4-06 (4C2)	Frequency Reference at Reference Loss	<div style="display: flex; justify-content: space-between; align-items: center;"> <span><b>All Modes</b></span> </div> <p>Sets the percentage of the frequency reference that the drive should run with when the frequency reference is lost.</p>	Default: 80% Min.: 0.0 Max.: 100.0	<a href="#">144</a>
L4-07 (470)	Speed Agreement Detection Selection	<div style="display: flex; justify-content: space-between; align-items: center;"> <span><b>All Modes</b></span> </div> <p>0: No detection during baseblock. 1: Detection always enabled.</p>	Default: 0 Range: 0, 1	<a href="#">144</a>

- <1> Default setting is dependent on parameter A1-02, Control Method Selection.

### ◆ L5: Fault Restart

No. (Addr. Hex)	Name	Description	Values	Page
L5-01 (49E)	Number of Auto Restart Attempts	<b>All Modes</b> Sets the number of times the drive may attempt to restart after the following faults occur: GF, LF, oC, ov, PF, rH, rr, oL1, oL2, oL3, oL4, STo, Uv1.	Default: 0 Min.: 0 Max.: 10	145
L5-02 (49F)	Auto Restart Fault Output Operation Selection	<b>All Modes</b> 0: Fault output not active. 1: Fault output active during restart attempt.	Default: 0 Range: 0, 1	145
L5-04 (46C)	Fault Reset Interval Time	<b>All Modes</b> Sets the amount of time to wait between performing fault restarts.	Default: 10.0 s Min.: 0.5 Max.: 600.0	145
L5-05 (467)	Fault Reset Operation Selection	<b>All Modes</b> 0: Continuously attempt to restart while incrementing restart counter only at a successful restart (same as F7 and G7). 1: Attempt to restart with the interval time set in L5-04 and increment the restart counter with each attempt (same as V7).	Default: 0 Range: 0, 1	146

### ◆ L6: Torque Detection

No. (Addr. Hex)	Name	Description	Values	Page
L6-01 (4A1)	Torque Detection Selection 1	<b>All Modes</b> 0: Disabled 1: oL3 detection only active during speed agree, operation continues after detection 2: oL3 detection always active during run, operation continues after detection 3: oL3 detection only active during speed agree, output shuts down on an oL3 fault 4: oL3 detection always active during run, output shuts down on an oL3 fault 5: UL3 detection only active during speed agree, operation continues after detection 6: UL3 detection always active during run, operation continues after detection 7: UL3 detection only active during speed agree, output shuts down on an oL3 fault 8: UL3 detection always active during run, output shuts down on an oL3 fault	Default: 0 Range: 0 to 8	147
L6-02 (4A2)	Torque Detection Level 1	<b>All Modes</b> Sets the overtorque and undertorque detection level.	Default: 150% Min.: 0 Max.: 300	147
L6-03 (4A3)	Torque Detection Time 1	<b>All Modes</b> Sets the time an overtorque or undertorque condition must exist to trigger torque detection 1.	Default: 0.1 s Min.: 0.0 Max.: 10.0	147
L6-04 (4A4)	Torque Detection Selection 2	<b>All Modes</b> 0: Disabled 1: oL4 detection only active during speed agree, operation continues after detection 2: oL4 detection always active during run, operation continues after detection 3: oL4 detection only active during speed agree, output shuts down on an oL4 fault 4: oL4 detection always active during run, output shuts down on an oL4 fault 5: UL4 detection only active during speed agree, operation continues after detection 6: UL4 detection always active during run, operation continues after detection 7: UL4 detection only active during speed agree, output shuts down on an oL4 fault 8: UL4 detection always active during run, output shuts down on an oL4 fault	Default: 0 Range: 0 to 8	147
L6-05 (4A5)	Torque Detection Level 2	<b>All Modes</b> Sets the overtorque and undertorque detection level.	Default: 150% Min.: 0 Max.: 300	147
L6-06 (4A6)	Torque Detection Time 2	<b>All Modes</b> Sets the time an overtorque or undertorque condition must exist to trigger torque detection 2.	Default: 0.1 s Min.: 0.0 Max.: 10.0	147

No. (Addr. Hex)	Name	Description	Values	Page
L6-08 (468)	Mechanical Weakening Detection Operation	<p><b>All Modes</b></p> <p>This function can detect an overtorque or undertorque in a certain speed range as a result of machine fatigue. It is triggered by a specified operation time and uses the oL1 detection settings (L6-01 and L6-03).</p> <p>0: Mechanical Weakening Detection disabled.</p> <p>1: Continue running (alarm only). Detected when the speed (signed) is greater than L6-09.</p> <p>2: Continue running (alarm only). Detected when the speed (not signed) is greater than L6-09.</p> <p>3: Interrupt drive output (fault). Detected when the speed (signed) is greater than L6-09.</p> <p>4: Interrupt drive output (fault). Detected when the speed (not signed) is greater than L6-09.</p> <p>5: Continue running (alarm only). Detected when the speed (signed) is less than L6-09.</p> <p>6: Continue running (alarm only). Detected when the speed (not signed) is less than L6-09.</p> <p>7: Interrupt drive output (fault). Detected when the speed (signed) is less than L6-09.</p> <p>8: Interrupt drive output (fault). Detected when the speed (not signed) is less than L6-09.</p>	Default: 0 Range: 0 to 8	148
L6-09 (469)	Mechanical Weakening Detection Speed Level	<p><b>All Modes</b></p> <p>Sets the speed that triggers Mechanical Weakening Detection. When L6-08 is set for an unsigned value, the absolute value is used if the setting is negative.</p>	Default: 110.0% Min.: -110.0 Max.: 110.0	148
L6-10 (46A)	Mechanical Weakening Detection Time	<p><b>All Modes</b></p> <p>Sets the time mechanical weakening has to be detected before an alarm or fault is triggered.</p>	Default: 0.1 s Min.: 0.0 Max.: 10.0	148
L6-11 (46B)	Mechanical Weakening Detection Start Time	<p><b>All Modes</b></p> <p>Sets the operation time (U1-04) required before Mechanical Weakening Detection is active.</p>	Default: 0 h Min.: 0 Max.: 65535	148

◆ L7: Torque Limit

No. (Addr. Hex)	Name	Description	Values	Page
L7-01 (4A7)	Forward Torque Limit	<p>Sets the torque limit value as a percentage of the motor rated torque. Four individual quadrants can be set.</p>	Default: 200% Min.: 0 Max.: 300	149
L7-02 (4A8)	Reverse Torque Limit		Default: 200% Min.: 0 Max.: 300	149
L7-03 (4A9)	Forward Regenerative Torque Limit		Default: 200% Min.: 0 Max.: 300	149
L7-04 (4AA)	Reverse Regenerative Torque Limit		Default: 200% Min.: 0 Max.: 300	149
L7-06 (4AC)	Torque Limit Integral Time Constant	<p><b>All Modes</b></p> <p>Sets the integral time constant for the torque limit.</p>	Default: 200 ms Min.: 5 Max.: 10000	149
L7-07 (4C9)	Torque Limit Control Method Selection during Accel/Decel	<p><b>All Modes</b></p> <p>0: Proportional control (changes to integral control at constant speed). Use this setting when acceleration to the desired speed should take precedence over the torque limit.</p> <p>1: Integral control. Set L7-07 to 1 if the torque limit should take precedence.</p>	Default: 0 Range: 0, 1	149

## A.10 L: Protection Function

No. (Addr. Hex)	Name	Description	Values	Page
L7-16 (44D)	Torque Limit Enable Time delay at start	<p><input type="radio"/> V/f   <input type="radio"/> V/f w PG   <input checked="" type="radio"/> OLV   <input type="radio"/> CLV</p> <p><input type="radio"/> OLV/PM   <input type="radio"/> AOLV/PM   <input type="radio"/> CLV/PM</p> <p>0: Disabled. 1: Enabled.</p> <p><b>Note:</b> Set this parameter to 0 to improve the response at the rapid addition and subtraction velocity at start.</p>	Default: 1 Range: 0, 1	149
L7-30 (1FD)	Regenerative torque limit mode selection	<p><input type="radio"/> V/f   <input type="radio"/> V/f w PG   <input checked="" type="radio"/> OLV   <input type="radio"/> CLV</p> <p><input type="radio"/> OLV/PM   <input type="radio"/> AOLV/PM   <input type="radio"/> CLV/PM</p> <p>Special Function of regenerative Torque limit for Omron (Same as G5HHP) 0: Standard mode (torque limit from all analogs and communications effective). 1: Independent mode (Only L7-03, 04, and H3-xx=12H (regenerative torque limit) are effective).</p>	Default: 0 Range: 0, 1	149

## ◆ L8: Drive Protection

No. (Addr. Hex)	Name	Description	Values	Page
L8-02 (4AE)	Overheat Alarm Level	<p><input checked="" type="radio"/> All Modes</p> <p>An overheat alarm occurs when heatsink temperature exceeds the L8-02 level.</p>	Default: </> Min.: 50 °C Max.: 150 °C	150
L8-03 (4AF)	Overheat Pre-Alarm Operation Selection	<p><input checked="" type="radio"/> All Modes</p> <p>0: Ramp to stop. A fault is triggered. 1: Coast to stop. A fault is triggered. 2: Fast Stop. Decelerate to stop using the deceleration time in C1-09. A fault is triggered. 3: Continue operation. An alarm is triggered. 4: Continue operation at reduced speed as set in L8-19.</p>	Default: 3 Range: 0 to 4	150
L8-05 (4B1)	Input Phase Loss Protection Selection	<p><input checked="" type="radio"/> All Modes</p> <p>Selects the detection of input current phase loss, power supply voltage imbalance, or main circuit electrolytic capacitor deterioration. 0: Disabled 1: Enabled</p>	Default: 1 Range: 0, 1	151
L8-07 (4B3)	Output Phase Loss Protection Selection	<p><input checked="" type="radio"/> All Modes</p> <p>0: Disabled 1: Enabled (triggered by a single phase loss) 2: Enabled (triggered when two phases are lost)</p>	Default: 1 Range: 0 to 2	152
L8-09 (4B5)	Output Ground Fault Detection Selection	<p><input checked="" type="radio"/> All Modes</p> <p>0: Disabled 1: Enabled</p>	Default: </> Range: 0, 1	152
L8-10 (4B6)	Heatsink Cooling Fan Operation Selection	<p><input checked="" type="radio"/> All Modes</p> <p>0: During run only. Fan operates only during run for L8-11 seconds after stop. 1: Fan always on. Cooling fan operates whenever the drive is powered up.</p>	Default: 0 Range: 0, 1	152
L8-11 (4B7)	Heatsink Cooling Fan Off Delay Time	<p><input checked="" type="radio"/> All Modes</p> <p>Sets a delay time to shut off the cooling fan after the Run command is removed when L8-10 = 0.</p>	Default: 60 s Min.: 0 Max.: 300	152
L8-12 (4B8)	Ambient Temperature Setting	<p><input checked="" type="radio"/> All Modes</p> <p>Enter the ambient temperature. This value adjusts the oL2 detection level.</p>	Default: 40 °C Min.: -10 Max.: 50	152
L8-15 (4BB)	oL2 Characteristics Selection at Low Speeds	<p><input checked="" type="radio"/> All Modes</p> <p>0: No oL2 level reduction below 6 Hz. 1: oL2 level is reduced linearly below 6 Hz. It is halved at 0 Hz.</p>	Default: 1 Range: 0, 1	153
L8-18 (4BE)	Software Current Limit Selection	<p><input type="radio"/> V/f   <input type="radio"/> V/f w PG   <input checked="" type="radio"/> OLV   <input checked="" type="radio"/> CLV</p> <p><input type="radio"/> OLV/PM   <input type="radio"/> AOLV/PM   <input type="radio"/> CLV/PM</p> <p>0: Disabled 1: Enabled</p>	Default: 0 Range: 0, 1	153

No. (Addr. Hex)	Name	Description	Values	Page
L8-19 (4BF)	Frequency Reduction Rate during Overheat Pre-Alarm	<b>All Modes</b> Specifies the frequency reference reduction gain at overheat pre-alarm when L8-03 = 4.	Default: 0.8 Min.: 0.1 Max.: 0.9	151
L8-32 (4E2)	Main Contactor and Cooling Fan Power Supply Failure Selection	<b>All Modes</b> Determines drive response when a fault occurs with the internal cooling fan. 0: Ramp to stop 1: Coast to stop 2: Fast stop (Decelerate to stop using the deceleration time set to C1-09) 3: Alarm only ("FAn" will flash) 4: Continue operation at reduced speed as set to L8-19.	Default: 1 Range: 0 to 4	153
L8-38 (4EF)	Carrier Frequency Reduction	<b>V/f</b> <b>V/f w PG</b> <b>OLV</b> <b>CLV</b> <b>OLV/PM</b> <b>AOLV/PM</b> <b>CLV/PM</b> 0: Disabled 1: Enabled below 6 Hz 2: Enabled for the entire speed range	Default: <4> Range: 0 to 2	153
L8-40 (4F1)	Carrier Frequency Reduction Off Delay Time	<b>V/f</b> <b>V/f w PG</b> <b>OLV</b> <b>CLV</b> <b>OLV/PM</b> <b>AOLV/PM</b> <b>CLV/PM</b> Sets the time that the drive continues running with reduced carrier frequency after the carrier reduction condition is gone. Setting 0.00 s disables the carrier frequency reduction time.	Default: <5> Min.: 0.00 s Max.: 2.00 s	154
L8-41 (4F2)	High Current Alarm Selection	<b>All Modes</b> 0: Disabled 1: Enabled. An alarm is triggered at output currents above 150% of drive rated current.	Default: 0 Range: 0, 1	154
L8-78 (2CC)	Module Output Loss Detection (LF3)	<b>All Modes</b> Detects the loss of an output phase in any of the inverter output modules. 0: Disabled 1: Enabled	Default: 1 Range: 0, 1	154
L8-86 (2F3)	Detection selection when panel fan fails	<b>All Modes</b> Detects the loss of the drive panel fan by the panel fan input. 0: Ramp Stop (Fault) 1: Coast Stop (Fault) 2: Fast Stop (Fault) 3: Continue Running (Alarm) 4: As for continue Running at L8-19 Speed 5: Disabled <b>Note:</b> Settings 3 and 4 reduce inverter O/L level from 100% to 80 %.	Default: 1 Range: 0, 5	154
L8-87 (2F4)	Detection selection when diode converter(s) fan(s) fail	<b>All Modes</b> Detects the loss of the diode converter fan(s) by the fan control input. 0: Ramp Stop (Fault) 1: Coast Stop (Fault) 2: Fast Stop (Fault) 3: Continue Running (Alarm) 4: As for continue Running at L8-19 Speed 5: Disabled <b>Note:</b> Settings 3 and 4 reduce inverter O/L level from 100% to 80 %.	Default: 1 Range: 0, 5	155

- <1> Default setting is dependent on parameters C6-01, Drive Duty Selection, and o2-04, Drive Model Selection.
- <4> Default setting is dependent on parameters A1-02, Control Method Selection, and o2-04, Drive Model Selection.
- <5> Default setting is dependent on parameter A1-02, Control Method Selection.

## A.11 n: Special Adjustment

The n parameters adjust more advanced performance characteristics such as Hunting Prevention, speed feedback detection, High Slip Braking, and Online Tuning for motor line-to-line resistance.

### ◆ n1: Hunting Prevention

No. (Addr. Hex)	Name	Description	Values	Page
n1-01 (580)	Hunting Prevention Selection	<input checked="" type="radio"/> V/f <input checked="" type="radio"/> V/f w PG <input type="radio"/> OLV <input type="radio"/> CLV <input type="radio"/> OLV/PM <input type="radio"/> AOLV/PM <input type="radio"/> CLV/PM 0: Disabled 1: Enabled	Default: 1 Range: 0, 1	156
n1-02 (581)	Hunting Prevention Gain Setting	<input checked="" type="radio"/> V/f <input checked="" type="radio"/> V/f w PG <input type="radio"/> OLV <input type="radio"/> CLV <input type="radio"/> OLV/PM <input type="radio"/> AOLV/PM <input type="radio"/> CLV/PM If the motor vibrates while lightly loaded, increase the gain by 0.1 until vibration ceases. If the motor stalls, decrease the gain by 0.1 until the stalling ceases.	Default: 1.00 Min.: 0.00 Max.: 2.50	156
n1-03 (582)	Hunting Prevention Time Constant	<input checked="" type="radio"/> V/f <input checked="" type="radio"/> V/f w PG <input type="radio"/> OLV <input type="radio"/> CLV <input type="radio"/> OLV/PM <input type="radio"/> AOLV/PM <input type="radio"/> CLV/PM Sets the time constant used for Hunting Prevention.	Default: <1> Min.: 0 ms Max.: 500 ms	156
n1-05 (530)	Hunting Prevention Gain while in Reverse	<input checked="" type="radio"/> V/f <input checked="" type="radio"/> V/f w PG <input type="radio"/> OLV <input type="radio"/> CLV <input type="radio"/> OLV/PM <input type="radio"/> AOLV/PM <input type="radio"/> CLV/PM Sets the gain used for Hunting Prevention. If set to 0, the gain set to n1-02 is used for operation in reverse.	Default: 0.00 Min.: 0.00 Max.: 2.50	156

<1> Default setting is dependent on parameter o2-04, Drive Model Selection.

### ◆ n2: Speed Feedback Detection Control (AFR) Tuning

No. (Addr. Hex)	Name	Description	Values	Page
n2-01 (584)	Speed Feedback Detection Control (AFR) Gain	<input type="radio"/> V/f <input type="radio"/> V/f w PG <input checked="" type="radio"/> OLV <input type="radio"/> CLV <input type="radio"/> OLV/PM <input type="radio"/> AOLV/PM <input type="radio"/> CLV/PM Sets the internal speed feedback detection control gain in the automatic frequency regulator (AFR). If hunting occurs, increase the set value. If response is low, decrease the set value.	Default: 1.00 Min.: 0.00 Max.: 10.00	156
n2-02 (585)	Speed Feedback Detection Control (AFR) Time Constant 1	<input type="radio"/> V/f <input type="radio"/> V/f w PG <input checked="" type="radio"/> OLV <input type="radio"/> CLV <input type="radio"/> OLV/PM <input type="radio"/> AOLV/PM <input type="radio"/> CLV/PM Sets the time constant used for speed feedback detection control (AFR).	Default: 50 ms Min.: 0 Max.: 2000	157
n2-03 (586)	Speed Feedback Detection Control (AFR) Time Constant 2	<input type="radio"/> V/f <input type="radio"/> V/f w PG <input checked="" type="radio"/> OLV <input type="radio"/> CLV <input type="radio"/> OLV/PM <input type="radio"/> AOLV/PM <input type="radio"/> CLV/PM Sets the AFR time constant to be used during Speed Search and during regen.	Default: 750 ms Min.: 0 Max.: 2000	157

### ◆ n3: High Slip Braking (HSB) and Overexcitation Braking

No. (Addr. Hex)	Name	Description	Values	Page
n3-13 (531)	Overexcitation Deceleration Gain	<input checked="" type="radio"/> V/f <input checked="" type="radio"/> V/f w PG <input checked="" type="radio"/> OLV <input checked="" type="radio"/> CLV <input type="radio"/> OLV/PM <input type="radio"/> AOLV/PM <input type="radio"/> CLV/PM Sets the gain applied to the V/f pattern during Overexcitation Deceleration (L3-04 = 4).	Default: 1.10 Min.: 1.00 Max.: 1.40	158



No. (Addr. Hex)	Name	Description	Values	Page
n3-21 (579)	High-Slip Suppression Current Level	<p><b>V/f</b> <b>V/f w PG</b> <b>OLV</b> <b>CLV</b></p> <p><input type="radio"/> OLV/PM <input type="radio"/> AOLV/PM <input type="radio"/> CLV/PM</p> <p>Sets output current level at which the drive will start reducing the overexcitation gain in order to prevent a too high motor slip during Overexcitation Deceleration. Set as a percentage of the drive rated current.</p>	Default: 100% Min.: 0 Max.: 150	158
n3-23 (57B)	Overexcitation Operation Selection	<p><b>V/f</b> <b>V/f w PG</b> <b>OLV</b> <b>CLV</b></p> <p><input type="radio"/> OLV/PM <input type="radio"/> AOLV/PM <input type="radio"/> CLV/PM</p> <p>0: Enabled in both directions 1: Enabled only when rotating forward 2: Enabled only when in reverse</p>	Default: 0 Range: 0 to 2	158

## A.12 o: Operator-Related Settings

The o parameters set up the digital operator displays.

### ◆ o1: Digital Operator Display Selection

No. (Addr. Hex)	Name	Description	Values	Page
o1-01 (500) 	Drive Mode Unit Monitor Selection	<b>All Modes</b> Selects the content of the last monitor that is shown when scrolling through Drive Mode display. Enter the last three digits of the monitor parameter number to be displayed: U□-□□.	Default: 106 (Monitor U1-06) Range: 104 to 809	159
o1-02 (501) 	User Monitor Selection after Power Up	<b>All Modes</b> 1: Frequency reference (U1-01) 2: Direction 3: Output frequency (U1-02) 4: Output current (U1-03) 5: User-selected monitor (set by o1-01)	Default: 1 Range: 1 to 5	159
o1-03 (502)	Digital Operator Display Selection	<b>All Modes</b> Sets the units the drive should use to display the frequency reference and motor speed monitors. 0: 0.01 Hz 1: 0.01% (100% = E1-04) 2: r/min (calculated using the number of motor poles setting in E2-04, E4-04, or E5-04) 3: User-selected units (set by o1-10 and o1-11)	Default: <1> Range: 0 to 3	159
o1-04 (503)	V/f Pattern Display Unit	  0: Hz 1: r/min	Default: <1> Range: 0, 1	160
o1-10 (520)	User-Set Display Units Maximum Value	<b>All Modes</b> These settings define the display values when o1-03 is set to 3.	Default: <2> Range: 1 to 60000	160
o1-11 (521)	User-Set Display Units Decimal Display	o1-10 sets the display value that is equal to the maximum output frequency. o1-11 sets the position of the decimal position.	Default: <2> Range: 0 to 3	160

<1> Default setting is dependent on parameter A1-02, Control Method Selection.

<2> Default setting is dependent on parameter o1-03, Digital Operator Display Selection.

### ◆ o2: Digital Operator Keypad Functions

No. (Addr. Hex)	Name	Description	Values	Page
o2-01 (505)	LO/RE Key Function Selection	<b>All Modes</b> 0: Disabled 1: Enabled. LO/RE key switches between LOCAL and REMOTE operation.	Default: 1 Range: 0, 1	160
o2-02 (506)	STOP Key Function Selection	<b>All Modes</b> 0: Disabled. STOP key is disabled in REMOTE operation. 1: Enabled. STOP key is always enabled.	Default: 1 Range: 0, 1	161
o2-03 (507)	User Parameter Default Value	<b>All Modes</b> 0: No change. 1: Set defaults. Saves parameter settings as default values for a User Initialization. 2: Clear all. Clears the default settings that have been saved for a User Initialization.	Default: 0 Range: 0 to 2	161
o2-04 (508)	Drive Model Selection	<b>All Modes</b> Enter the drive model. Setting required only if installing a new control board.	Default: Determined by drive capacity	161

No. (Addr. Hex)	Name	Description	Values	Page
o2-05 (509)	Frequency Reference Setting Method Selection	<b>All Modes</b> 0: ENTER key must be pressed to enter a frequency reference. 1: ENTER key is not required. The frequency reference can be adjusted using the up and down arrow keys only.	Default: 0 Range: 0, 1	161
o2-06 (50A)	Operation Selection when Digital Operator is Disconnected	<b>All Modes</b> 0: The drive continues operating if the digital operator is disconnected. 1: An oPr fault is triggered and the motor coasts to stop.	Default: 1 Range: 0, 1	162
o2-07 (527)	Motor Direction at Power Up when Using Operator	<b>All Modes</b> 0: Forward 1: Reverse This parameter requires assigning drive operation to the digital operator.	Default: 0 Range: 0, 1	162
o2-09 (50D)	–	Factory use.	–	–

◆ o3: Copy Function

No. (Addr. Hex)	Name	Description	Values	Page
o3-01 (515)	Copy Function Selection	<b>All Modes</b> 0: No action 1: Read parameters from the drive, saving them onto the digital operator. 2: Copy parameters from the digital operator, writing them to the drive. 3: Verify parameter settings on the drive to check if they match the data saved on the operator.	Default: 0 Range: 0 to 3	162
o3-02 (516)	Copy Allowed Selection	<b>All Modes</b> 0: Read operation prohibited 1: Read operation allowed	Default: 0 Range: 0, 1	162

◆ o4: Maintenance Monitor Settings

No. (Addr. Hex)	Name	Description	Values	Page
o4-01 (50B)	Cumulative Operation Time Setting	<b>All Modes</b> Sets the value for the cumulative operation time of the drive in units of 10 h.	Default: 0 h Min.: 0 Max.: 9999	163
o4-02 (50C)	Cumulative Operation Time Selection	<b>All Modes</b> 0: Logs power-on time 1: Logs operation time when the drive output is active (output operation time).	Default: 0 Range: 0, 1	163
o4-03 (50E)	Cooling Fan Operation Time Setting	<b>All Modes</b> Sets the value of the fan operation time monitor U4-03 in units of 10 h.	Default: 0 h Min.: 0 Max.: 9999	163
o4-05 (51D)	Capacitor Maintenance Setting	<b>All Modes</b> Sets the value of the Maintenance Monitor for the capacitors. See U4-05 to check when the capacitors may need to be replaced.	Default: 0% Min.: 0 Max.: 150	163
o4-07 (523)	DC Bus Pre-Charge Relay Maintenance Setting	<b>All Modes</b> Sets the value of the Maintenance Monitor for the soft charge bypass relay. See U4-06 to check when the bypass relay may need to be replaced.	Default: 0% Min.: 0 Max.: 150	163
o4-09 (525)	IGBT Maintenance Setting	<b>All Modes</b> Sets the value of the Maintenance Monitor for the IGBTs. See U4-07 for IGBT replacement times.	Default: 0% Min.: 0 Max.: 150	163
o4-11 (510)	U2, U3 Initialization	<b>All Modes</b> 0: U2-□□ and U3-□□ monitor data is not reset when the drive is initialized (A1-03). 1: U2-□□ and U3-□□ monitor data is reset when the drive is initialized (A1-03).	Default: 0 Range: 0, 1	164

## A.12 o: Operator-Related Settings

No. (Addr. Hex)	Name	Description	Values	Page
o4-12 (512)	kWh Monitor Initialization	<p><b>All Modes</b></p> <p>0: U4-10 and U4-11 monitor data is not reset when the drive is initialized (A1-03).            1: U4-10 and U4-11 monitor data is reset when the drive is initialized (A1-03).</p>	Default: 0 Range: 0, 1	<i>164</i>
o4-13 (528)	Number of Run Commands Counter Initialization	<p><b>All Modes</b></p> <p>0: Number of Run commands counter is not reset when the drive is initialized (A1-03).            1: Number of Run commands counter is reset when the drive is initialized (A1-03).</p>	Default: 0 Range: 0, 1	<i>164</i>

## A.13 DriveWorksEZ Parameters

### ◆ q: DriveWorksEZ Parameters

No. (Addr. Hex)	Name	Description	Values	Page
q1-01 to q6-07 (1600 to 1746)	DriveWorksEZ Parameters	<b>All Modes</b> Reserved for DriveWorksEZ	Refer to Help in the DWEZ software.	<i>164</i>

### ◆ r: DriveWorksEZ Connection Parameters

No. (Addr. Hex)	Name	Description	Values	Page
r1-01 to r1-40 (1840 to 1867)	DriveWorksEZ Connection Parameters 1 to 20 (upper/ lower)	<b>All Modes</b> DriveWorksEZ Connection Parameters 1 to 20 (upper/lower)	Default: 0 Min.: 0 Max.: FFFF	<i>164</i>

## A.14 T: Motor Tuning

Enter data into the following parameters to tune the motor and drive for optimal performance.

### ◆ T1: Induction Motor Auto-Tuning

No. (Addr. Hex)	Name	Description	Values	Page
T1-00 (700)	Motor 1/Motor 2 Selection	<p><input checked="" type="radio"/> V/f   <input checked="" type="radio"/> V/f w PG   <input checked="" type="radio"/> OLV   <input checked="" type="radio"/> CLV</p> <p><input type="radio"/> OLV/PM   <input type="radio"/> AOLV/PM   <input type="radio"/> CLV/PM</p> <p>1: Motor 1 (sets E1-□□, E2-□□) 2: Motor 2 (sets E3-□□, E4-□□)</p>	Default: 1 Range: 1, 2	165
T1-01 (701) </>	Auto-Tuning Mode Selection	<p><input checked="" type="radio"/> V/f   <input checked="" type="radio"/> V/f w PG   <input checked="" type="radio"/> OLV   <input checked="" type="radio"/> CLV</p> <p><input type="radio"/> OLV/PM   <input type="radio"/> AOLV/PM   <input type="radio"/> CLV/PM</p> <p>0: Rotational Auto-Tuning 1: Stationary Auto-Tuning 1 2: Stationary Auto-Tuning for Line-to-Line Resistance 4: Stationary Auto-Tuning 2</p>	Default: 0 Range: 0, 1, 2, 4 </>	165
T1-02 (702)	Motor Rated Power	<p><input checked="" type="radio"/> V/f   <input checked="" type="radio"/> V/f w PG   <input checked="" type="radio"/> OLV   <input checked="" type="radio"/> CLV</p> <p><input type="radio"/> OLV/PM   <input type="radio"/> AOLV/PM   <input type="radio"/> CLV/PM</p> <p>Sets the motor rated power as specified on the motor nameplate.</p> <p><b>Note:</b> Use the following formula to convert horsepower into kilowatts: 1HP = 0.746 kW.</p>	Default: </> Min.: 0.00 kW Max.: 650.00 kW	165
T1-03 (703)	Motor Rated Voltage	<p><input checked="" type="radio"/> V/f   <input checked="" type="radio"/> V/f w PG   <input checked="" type="radio"/> OLV   <input checked="" type="radio"/> CLV</p> <p><input type="radio"/> OLV/PM   <input type="radio"/> AOLV/PM   <input type="radio"/> CLV/PM</p> <p>Sets the motor rated voltage as specified on the motor nameplate.</p>	Default: 400.0 V </> Min: 0.0 Max: 510.0 </>	165
T1-04 (704)	Motor Rated Current	<p><input checked="" type="radio"/> V/f   <input checked="" type="radio"/> V/f w PG   <input checked="" type="radio"/> OLV   <input checked="" type="radio"/> CLV</p> <p><input type="radio"/> OLV/PM   <input type="radio"/> AOLV/PM   <input type="radio"/> CLV/PM</p> <p>Sets the motor rated current as specified on the motor nameplate.</p>	Default: </> Min.: 10% of drive rated current Max.: 200% of drive rated current	166
T1-05 (705)	Motor Base Frequency	<p><input checked="" type="radio"/> V/f   <input checked="" type="radio"/> V/f w PG   <input checked="" type="radio"/> OLV   <input checked="" type="radio"/> CLV</p> <p><input type="radio"/> OLV/PM   <input type="radio"/> AOLV/PM   <input type="radio"/> CLV/PM</p> <p>Sets the rated frequency of the motor as specified on the motor nameplate.</p>	Default: 60.0 Hz Min.: 0.0 Max.: 400.0	166
T1-06 (706)	Number of Motor Poles	<p><input checked="" type="radio"/> V/f   <input checked="" type="radio"/> V/f w PG   <input checked="" type="radio"/> OLV   <input checked="" type="radio"/> CLV</p> <p><input type="radio"/> OLV/PM   <input type="radio"/> AOLV/PM   <input type="radio"/> CLV/PM</p> <p>Sets the number of motor poles as specified on the motor nameplate.</p>	Default: 4 Min.: 2 Max.: 48	166
T1-07 (707)	Motor Base Speed	<p><input checked="" type="radio"/> V/f   <input checked="" type="radio"/> V/f w PG   <input checked="" type="radio"/> OLV   <input checked="" type="radio"/> CLV</p> <p><input type="radio"/> OLV/PM   <input type="radio"/> AOLV/PM   <input type="radio"/> CLV/PM</p> <p>Sets the rated speed of the motor as specified on the motor nameplate.</p>	Default: 1750 r/min Min.: 0 Max.: 24000	166
T1-08 (708)	PG Number of Pulses Per Revolution	<p><input type="radio"/> V/f   <input type="radio"/> V/f w PG   <input type="radio"/> OLV   <input checked="" type="radio"/> CLV</p> <p><input type="radio"/> OLV/PM   <input type="radio"/> AOLV/PM   <input type="radio"/> CLV/PM</p> <p>Sets the number of pulses per revolution for the PG being used (pulse generator or encoder).</p>	Default: 1024 ppr Min.: 1 Max.: 60000	166
T1-09 (709)	Motor No-Load Current (Stationary Auto-Tuning)	<p><input type="radio"/> V/f   <input type="radio"/> V/f w PG   <input checked="" type="radio"/> OLV   <input checked="" type="radio"/> CLV</p> <p><input type="radio"/> OLV/PM   <input type="radio"/> AOLV/PM   <input type="radio"/> CLV/PM</p> <p>Sets the no-load current for the motor. After setting the motor capacity to T1-02 and the motor rated current to T1-04, this parameter will automatically display the no-load current for a standard 4-pole Yaskawa motor. Enter the no-load current as indicated on the motor test report.</p>	Default: – Min.: 0 A Max.: T1-04	166
T1-10 (70A)	Motor Rated Slip (Stationary Auto-Tuning)	<p><input type="radio"/> V/f   <input type="radio"/> V/f w PG   <input checked="" type="radio"/> OLV   <input checked="" type="radio"/> CLV</p> <p><input type="radio"/> OLV/PM   <input type="radio"/> AOLV/PM   <input type="radio"/> CLV/PM</p> <p>Sets the motor rated slip. After setting the motor capacity to T1-02, this parameter will automatically display the motor slip for a standard 4-pole Yaskawa motor. Enter the motor slip as indicated on the motor test report.</p>	Default: – Min.: 0.00 Hz Max.: 20.00 Hz	166

No. (Addr. Hex)	Name	Description	Values	Page
T1-11 (70B)	Motor Iron Loss	<p> <input type="radio"/> V/f   <input checked="" type="radio"/> V/f w PG   <input type="radio"/> OLV   <input type="radio"/> CLV  <input type="radio"/> OLV/PM   <input type="radio"/> AOLV/PM   <input type="radio"/> CLV/PM                 </p> <p>Sets the iron loss for determining the Energy Saving coefficient. The value is set to E2-10 (motor iron loss) set when the power is cycled. If T1-02 is changed, a default value appropriate for the motor capacity that was entered will appear.</p>	Default: 14 W <5> Min.: 0 Max.: 65535	167

- <1> The availability of certain Auto-Tuning methods depends on the control mode selected for the drive.
- <2> Default setting is determined by parameter A1-02, Control Method Setting.
- <3> Default setting is dependent on parameter o2-04, Drive Model Selection.
- <4> Values shown are specific to 400 V class drives. Multiply the value by 1.4375 for 575 V class drives. Multiply the value by 1.725 for 690 V class drives.
- <5> Default setting value differs depending on the motor code value and motor parameter settings.

### ◆ T3: ASR and Inertia Tuning

No. (Addr. Hex)	Name	Description	Values	Page
T3-01 (760) <1>	Test Signal Frequency	<p> <input type="radio"/> V/f   <input type="radio"/> V/f w PG   <input type="radio"/> OLV   <input checked="" type="radio"/> CLV  <input type="radio"/> OLV/PM   <input type="radio"/> AOLV/PM   <input checked="" type="radio"/> CLV/PM                 </p> <p>Sets the frequency of the test signal used during Inertia Tuning and ASR Gain Auto-Tuning. Reduce this value if the inertia is large or if a fault occurs.</p>	Default: 3.0 Hz Min.: 0.1 Max.: 20.0	167
T3-02 (761) <1>	Test Signal Amplitude	<p> <input type="radio"/> V/f   <input type="radio"/> V/f w PG   <input type="radio"/> OLV   <input checked="" type="radio"/> CLV  <input type="radio"/> OLV/PM   <input type="radio"/> AOLV/PM   <input checked="" type="radio"/> CLV/PM                 </p> <p>Sets the amplitude of the test signal used during Inertia and ASR Gain Auto-Tuning. Reduce this value if the inertia is too large or if a fault occurs.</p>	Default: 0.5 rad Min.: 0.1 Max.: 10.0	167
T3-03 (762) <1>	Motor Inertia	<p> <input type="radio"/> V/f   <input type="radio"/> V/f w PG   <input type="radio"/> OLV   <input checked="" type="radio"/> CLV  <input type="radio"/> OLV/PM   <input type="radio"/> AOLV/PM   <input checked="" type="radio"/> CLV/PM                 </p> <p>Sets the motor inertia. Default setting is the inertia of a Yaskawa motor.</p>	Default: <2> <3> Min.: 0.0001 kgm <sup>2</sup> Max.: 600.00 kgm <sup>2</sup>	167
T3-04 (763) <1>	System Response Frequency	<p> <input type="radio"/> V/f   <input type="radio"/> V/f w PG   <input type="radio"/> OLV   <input checked="" type="radio"/> CLV  <input type="radio"/> OLV/PM   <input type="radio"/> AOLV/PM   <input checked="" type="radio"/> CLV/PM                 </p> <p>Sets the response frequency of the mechanical system connected to the motor. Oscillation may result if set too high.</p>	Default: 10.0 Hz Min.: 0.1 Max.: 50.0	167

- <1> Displayed only when performing Inertia Tuning or ASR Gain Auto-Tuning (T1-01 = 8 or T2-01 = 9).
- <2> Default setting is dependent on parameter E5-01, Motor Code Selection.
- <3> Default setting is dependent on parameters C6-01, Drive Duty Selection, and o2-04, Drive Model Selection.

## A.15 U: Monitors

Monitor parameters allow the user to view drive status, fault information, and other data concerning drive operation.

### ◆ U1: Operation Status Monitors

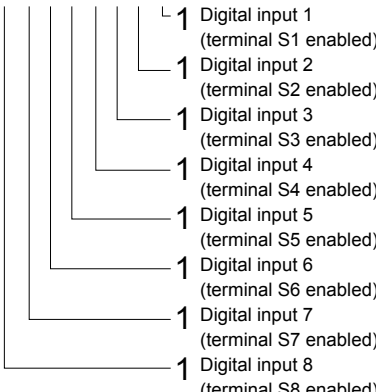
No. (Addr. Hex)	Name	Description	Analog Output Level	Unit
U1-01 (40)	Frequency Reference	<b>All Modes</b> Monitors the frequency reference. Display units are determined by o1-03.	10 V: Max frequency	0.01 Hz
U1-02 (41)	Output Frequency	<b>All Modes</b> Displays the output frequency. Display units are determined by o1-03.	10 V: Max frequency	0.01 Hz
U1-03 (42)	Output Current	<b>All Modes</b> Displays the output current. <b>Note:</b> The unit is expressed in 1 A for models CIMR-A□4A0930 and 4A1200.	10 V: Drive rated current	<> <>
U1-04 (43)	Control Method	<b>All Modes</b> 0: V/f Control 1: V/f Control with PG 2: Open Loop Vector Control 3: Closed Loop Vector Control	No signal output available	–
U1-05 (44)	Motor Speed	<input type="radio"/> V/f <input checked="" type="radio"/> V/f w PG <input checked="" type="radio"/> OLV <input checked="" type="radio"/> CLV <input type="radio"/> OLV/PM <input checked="" type="radio"/> AOLV/PM <input checked="" type="radio"/> CLV/PM Displays the motor speed feedback. Display units are determined by o1-03.	10 V: Max frequency	0.01 Hz
U1-06 (45)	Output Voltage Reference	<b>All Modes</b> Displays the output voltage.	10 V: 200 Vrms <>	0.1 Vac
U1-07 (46)	DC Bus Voltage	<b>All Modes</b> Displays the DC bus voltage.	10 V: 400 V <>	1 Vdc
U1-08 (47)	Output Power	<b>All Modes</b> Displays the output power (this value is calculated internally).	10 V: Drive rated power (kW)	<>
U1-09 (48)	Torque Reference	<input type="radio"/> V/f <input type="radio"/> V/f w PG <input checked="" type="radio"/> OLV <input checked="" type="radio"/> CLV <input type="radio"/> OLV/PM <input checked="" type="radio"/> AOLV/PM <input checked="" type="radio"/> CLV/PM Monitors the internal torque reference.	10 V: Motor rated torque	0.1%
U1-10 (49)	Input Terminal Status	<b>All Modes</b> Displays the input terminal status. <b>U1 - 10 = 00000000</b>  <ul style="list-style-type: none"><li>1 Digital input 1 (terminal S1 enabled)</li><li>1 Digital input 2 (terminal S2 enabled)</li><li>1 Digital input 3 (terminal S3 enabled)</li><li>1 Digital input 4 (terminal S4 enabled)</li><li>1 Digital input 5 (terminal S5 enabled)</li><li>1 Digital input 6 (terminal S6 enabled)</li><li>1 Digital input 7 (terminal S7 enabled)</li><li>1 Digital input 8 (terminal S8 enabled)</li></ul>	No signal output available	–

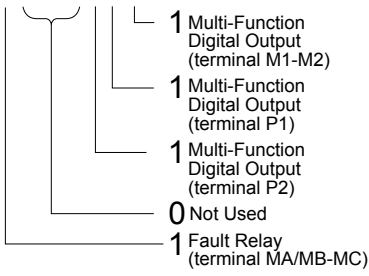
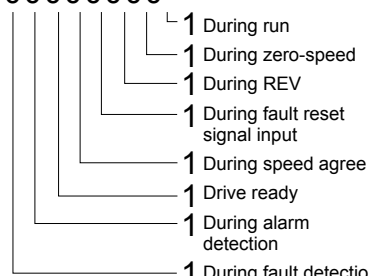
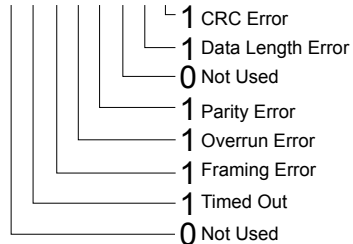

No. (Addr. Hex)	Name	Description	Analog Output Level	Unit
U1-11 (4A)	Output Terminal Status	<p><b>All Modes</b> Displays the output terminal status.</p> <p>U1 - 11 = 00000000</p> 	No signal output available	1
U1-12 (4B)	Drive Status	<p><b>All Modes</b> Verifies the drive operation status.</p> <p>U1 - 12 = 00000000</p> 	No signal output available	-
U1-13 (4E)	Terminal A1 Input Level	<p><b>All Modes</b> Displays the signal level to analog input terminal A1.</p>	10 V: 100%	0.1%
U1-14 (4F)	Terminal A2 Input Level	<p><b>All Modes</b> Displays the signal level to analog input terminal A2.</p>	10 V: 100%	0.1%
U1-15 (50)	Terminal A3 Input Level	<p><b>All Modes</b> Displays the signal level to analog input terminal A3.</p>	10 V: 100%	0.1%
U1-16 (53)	Output Frequency after Soft Starter	<p><b>All Modes</b> Displays output frequency with ramp time and S-curves. Units determined by o1-03.</p>	10 V: Max frequency	0.01 Hz
U1-17 (58)	DI-A3 Input Status	<p><b>All Modes</b> Displays the reference value input from the DI-A3 option card. Display will appear in hexadecimal as determined by the digital card input selection in F3-01. 3FFFF: Set (1 bit) + sign (1 bit) + 16 bit</p>	No signal output available	-
U1-18 (61)	oPE Fault Parameter	<p><b>All Modes</b> Displays the parameter number that caused the oPE□□ or Err (EEPROM write error) error.</p>	No signal output available	-
U1-19 (66)	MEMOBUS/Modbus Error Code	<p><b>All Modes</b> Displays the contents of a MEMOBUS/Modbus error.</p> <p>U1 - 19 = 00000000</p> 	No signal output available	-

## A.15 U: Monitors

No. (Addr. Hex)	Name	Description	Analog Output Level	Unit
U1-21 (77)	AI-A3 Terminal V1 Input Voltage Monitor	<b>All Modes</b> Displays the input voltage to terminal V1 on analog input card AI-A3.	10 V: 100%	0.1%
U1-22 (72A)	AI-A3 Terminal V2 Input Voltage Monitor	<b>All Modes</b> Displays the input voltage to terminal V2 on analog input card AI-A3.	10 V: 100%	0.1%
U1-23 (72B)	AI-A3 Terminal V3 Input Voltage Monitor	<b>All Modes</b> Displays the input voltage to terminal V3 on analog input card AI-A3.	10 V: 100%	0.1%
U1-24 (7D)	Input Pulse Monitor	<b>All Modes</b> Displays the frequency to pulse train input terminal RP.	Determined by H6-02	1 Hz
U1-25 (4D)	Software Number of Master CPU (Flash)	<b>All Modes</b> FLASH ID: Software number of Master CPU	No signal output available	–
U1-26 (5B)	Software No. of Slave CPU (ROM)	<b>All Modes</b> ROM ID: Software number of Slave CPU	No signal output available	–
U1-27 (7A8)	MessageID (OPR)	<b>All Modes</b> Factory use	No signal output available	–
U1-28 (7A9)	MessageID (INV)	<b>All Modes</b> Factory use	No signal output available	–
U1-29 (7AA)	Software No. (PWM)	<b>All Modes</b> PWM ID: Software No. of slave or inverter module axis processors <b>Note:</b> This parameter is only available in models CIMR-A□4A0930 and 4A1200.	No signal output available	–

- <1> The number of decimal places in the parameter value depends on the drive model and the ND/HD selection in parameter C6-01. This value has two decimal places (0.01 A) if the drive is set for a maximum applicable motor capacity up to and including 11 kW, and one decimal place (0.1 A) if the maximum applicable motor capacity is higher than 11 kW.
- <2> When reading the value of this monitor via MEMOBUS/Modbus, a value of 8192 is equal to 100% of the drive rated output current.
- <3> Values shown are specific to 400 V class drives. Multiply the value by 1.4375 for 575 V class drives. Multiply the value by 1.725 for 690 V class drives.
- <4> The display resolution depends on the ND/HD selection in parameter C6-01. This value has two decimal places (0.01 kW) if the drive is set for a maximum applicable motor capacity up to and including 11 kW, and one decimal place (0.1 kW) if the maximum applicable motor capacity is higher than 11 kW.

## ◆ U2: Fault Trace

No. (Addr. Hex)	Name	Description	Analog Output Level	Unit
U2-01 (80)	Current Fault	<b>All Modes</b> Displays the current fault.	No signal output available	–
U2-02 (81)	Previous Fault	<b>All Modes</b> Displays the previous fault.	No signal output available	–
U2-03 (82)	Frequency Reference at Previous Fault	<b>All Modes</b> Displays the frequency reference at the previous fault.	No signal output available	0.01 Hz
U2-04 (83)	Output Frequency at Previous Fault	<b>All Modes</b> Displays the output frequency at the previous fault.	No signal output available	0.01 Hz
U2-05 (84)	Output Current at Previous Fault	<b>All Modes</b> Displays the output current at the previous fault.	No signal output available	<I> <I>
U2-06 (85)	Motor Speed at Previous Fault	<input type="button" value="V/f"/> <input type="button" value="V/f w PG"/> <input type="button" value="OLV"/> <input type="button" value="CLV"/> <input type="button" value="OLV/PM"/> <input type="button" value="AOLV/PM"/> <input type="button" value="CLV/PM"/> Displays the motor speed at the previous fault.	No signal output available	0.01 Hz
U2-07 (86)	Output Voltage at Previous Fault	<b>All Modes</b> Displays the output voltage at the previous fault.	No signal output available	0.1 Vac

No. (Addr. Hex)	Name	Description	Analog Output Level	Unit
U2-08 (87)	DC Bus Voltage at Previous Fault	<b>All Modes</b> Displays the DC bus voltage at the previous fault.	No signal output available	1 Vdc
U2-09 (88)	Output Power at Previous Fault	<b>All Modes</b> Displays the output power at the previous fault.	No signal output available	0.1 kW
U2-10 (89)	Torque Reference at Previous Fault	<input type="button" value="V/f"/> <input type="button" value="V/f w PG"/> <input checked="" type="button" value="OLV"/> <input checked="" type="button" value="CLV"/> <input type="button" value="OLV/PM"/> <input checked="" type="button" value="AOLV/PM"/> <input checked="" type="button" value="CLV/PM"/> Displays the torque reference at the previous fault.	No signal output available	0.1%
U2-11 (8A)	Input Terminal Status at Previous Fault	<b>All Modes</b> Displays the input terminal status at the previous fault. Displayed as in U1-10.	No signal output available	–
U2-12 (8B)	Output Terminal Status at Previous Fault	<b>All Modes</b> Displays the output status at the previous fault. Displays the same status displayed in U1-11.	No signal output available	–
U2-13 (8C)	Drive Operation Status at Previous Fault	<b>All Modes</b> Displays the operation status of the drive at the previous fault. Displays the same status displayed in U1-12.	No signal output available	–
U2-14 (8D)	Cumulative Operation Time at Previous Fault	<b>All Modes</b> Displays the cumulative operation time at the previous fault.	No signal output available	1 h
U2-15 (7E0)	Soft Starter Speed Reference at Previous Fault	<b>All Modes</b> Displays the speed reference for the soft starter at the previous fault.	No signal output available	0.01 Hz
U2-16 (7E1)	Motor q-Axis Current at Previous Fault	<input type="button" value="V/f"/> <input type="button" value="V/f w PG"/> <input checked="" type="button" value="OLV"/> <input checked="" type="button" value="CLV"/> <input checked="" type="button" value="OLV/PM"/> <input checked="" type="button" value="AOLV/PM"/> <input checked="" type="button" value="CLV/PM"/> Displays the q-axis current for the motor at the previous fault.	No signal output available	0.10%
U2-17 (7E2)	Motor d-Axis Current at Previous Fault	<input type="button" value="V/f"/> <input type="button" value="V/f w PG"/> <input checked="" type="button" value="OLV"/> <input checked="" type="button" value="CLV"/> <input checked="" type="button" value="OLV/PM"/> <input checked="" type="button" value="AOLV/PM"/> <input checked="" type="button" value="CLV/PM"/> Displays the d-axis current for the motor at the previous fault.	No signal output available	0.10%
U2-19 (7EC)	Rotor Deviation at Previous Fault	<input type="button" value="V/f"/> <input type="button" value="V/f w PG"/> <input type="button" value="OLV"/> <input type="button" value="CLV"/> <input type="button" value="OLV/PM"/> <input checked="" type="button" value="AOLV/PM"/> <input type="button" value="CLV/PM"/> Displays the degree of rotor deviation when the most recent fault occurred (same status will appear as shown in U6-10).	No signal output available	0.1 deg
U2-20 (8E)	Heatsink Temperature at Previous Fault	<b>All Modes</b> Displays the temperature of the heatsink when the most recent fault occurred.	No signal output available	1 °C
U2-27 (7FA)	Motor Temperature at Previous Fault (NTC)	<b>All Modes</b> Displays the temperature of the motor when the most recent fault occurred. <b>Note:</b> This parameter is only available in models CIMR-A□4A0930 and 4A1200.	No signal output available	1 °C
U2-28 (7FC)	Fault Slave Location Monitor	Displays the module where the Fault Slave occurred as a binary number. Bit 0: Axis 1 Bit 1: Axis 2 Bit 2: Axis 3 Bit 3: Axis 4 Bit 4: Axis 5	No signal output available	1

- <1> The number of decimal places in the parameter value depends on the drive model and the ND/HD selection in parameter C6-01. This value has two decimal places (0.01 A) if the drive is set for a maximum applicable motor capacity up to and including 11 kW, and one decimal place (0.1 A) if the maximum applicable motor capacity is higher than 11 kW.
- <2> When reading the value of this monitor via MEMOBUS/Modbus, a value of 8192 is equal to 100% of the drive rated output current.

**◆ U3: Fault History**

No. (Addr. Hex)	Name	Description	Analog Output Level	Unit
U3-01 to U3-04 (90 to 93 (800 to 803))	First to 4th Most Recent Fault	<b>All Modes</b> Displays the first to the fourth most recent faults.	No signal output available	–
U3-05 to U3-10 (804 to 809)	5th to 10th Most Recent Fault	<b>All Modes</b> Displays the fifth to the tenth most recent faults. After ten faults, data for the oldest fault is deleted. The most recent fault appears in U3-01, with the next most recent fault appearing in U3-02. The data is moved to the next monitor parameter each time a fault occurs.	No signal output available	–
U3-11 to U3-14 (94 to 97 (80A to 80D))	Cumulative Operation Time at 1st to 4th Most Recent Fault	<b>All Modes</b> Displays the cumulative operation time when the first to the fourth most recent faults occurred.	No signal output available	1 h
U3-15 to U3-20 (80E to 813)	Cumulative Operation Time at 5th to 10th Most Recent Fault	<b>All Modes</b> Displays the cumulative operation time when the fifth to the tenth most recent faults occurred.	No signal output available	1 h

**◆ U4: Maintenance Monitors**

No. (Addr. Hex)	Name	Description	Analog Output Level	Unit
U4-01 (4C)	Cumulative Operation Time	<b>All Modes</b> Displays the cumulative operation time of the drive. The value for the cumulative operation time counter can be reset in parameter o4-01. Use parameter o4-02 to determine if the operation time should start as soon as the power is switched on or only while the Run command is present. The maximum number displayed is 99999, after which the value is reset to 0.	No signal output available	1 h
U4-02 (75)	Number of Run Commands	<b>All Modes</b> Displays the number of times the Run command is entered. Reset the number of Run commands using parameter o4-13. This value will reset to 0 and start counting again after reaching 65535.	No signal output available	1 Time
U4-03 (67)	Cooling Fan Operation Time	<b>All Modes</b> Displays the cumulative operation time of the cooling fan. The default value for the fan operation time is reset in parameter o4-03. This value will reset to 0 and start counting again after reaching 99999.	No signal output available	1 h
U4-04 (7E)	Cooling Fan Maintenance	<b>All Modes</b> Displays main cooling fan usage time as a percentage of its expected performance life. Parameter o4-03 can be used to reset this monitor.	No signal output available	1%
U4-05 (7C)	Capacitor Maintenance	<b>All Modes</b> Displays main circuit capacitor usage time as a percentage of their expected performance life. Parameter o4-05 can be used to reset this monitor.	No signal output available	1%
U4-06 (7D6)	Soft Charge Bypass Relay Maintenance	<b>All Modes</b> Displays the soft charge bypass relay maintenance time as a percentage of its estimated performance life. Parameter o4-07 can be used to reset this monitor.	No signal output available	1%
U4-07 (7D7)	IGBT Maintenance	<b>All Modes</b> Displays IGBT usage time as a percentage of the expected performance life. Parameter o4-09 can be used to reset this monitor.	No signal output available	1%
U4-08 (68)	Heatsink Temperature	<b>All Modes</b> Displays the heatsink temperature.	10 V: 100 °C	1 °C
U4-09 (5E)	LED Check	<b>All Modes</b> Lights all segments of the LED to verify that the display is working properly.	No signal output available	–

No. (Addr. Hex)	Name	Description	Analog Output Level	Unit
U4-10 (5C)	kWh, Lower 4 Digits	<b>All Modes</b> Monitors the drive output power. The value is shown as a 9-digit number displayed across two monitor parameters, U4-10 and U4-11.	No signal output available	1 kWh
U4-11 (5D)	kWh, Upper 5 Digits	Example: 12345678.9 kWh is displayed as: U4-10: 678.9 kWh U4-11: 12345 MWh	No signal output available	1 MWh
U4-13 (7CF)	Peak Hold Current	<b>All Modes</b> Displays the highest current value that occurred during run.	No signal output available	0.01 A <1> <2>
U4-14 (7D0)	Peak Hold Output Frequency	<b>All Modes</b> Displays the output frequency when the current value shown in U4-13 occurred.	No signal output available	0.01 Hz
U4-16 (7D8)	Motor Overload Estimate (oL1)	<b>All Modes</b> Shows the value of the motor overload detection accumulator. 100% is equal to the oL1 detection level.	10 V: 100%	0.1%
U4-18 (7DA)	Frequency Reference Source Selection	<b>All Modes</b> Displays the source for the frequency reference as XY- <i>nn</i> . <b>X: indicates which reference is used:</b> 1 = Reference 1 (b1-01) 2 = Reference 2 (b1-15) <b>Y-<i>nn</i>: indicates the reference source</b> 0-01 = Digital operator 1-01 = Analog (terminal A1) 1-02 = Analog (terminal A2) 1-03 = Analog (terminal A3) 2-02 to 17 = Multi-step speed (d1-02 to 17) 3-01 = MEMOBUS/Modbus communications 4-01 = Communication option card 5-01 = Pulse input 7-01 = DWEZ	No signal output available	–
U4-19 (7DB)	Frequency Reference from MEMOBUS/Modbus Comm.	<b>All Modes</b> Displays the frequency reference provided by MEMOBUS/Modbus (decimal).	No signal output available	0.01%
U4-20 (7DC)	Option Frequency Reference	<b>All Modes</b> Displays the frequency reference input by an option card (decimal).	No signal output available	–
U4-21 (7DD)	Run Command Source Selection	<b>All Modes</b> Displays the source for the Run command as XY- <i>nn</i> . <b>X: Indicates which Run source is used:</b> 1 = Reference 1 (b1-02) 2 = Reference 2 (b1-16) <b>Y: Input power supply data</b> 0 = Digital operator 1 = External terminals 3 = MEMOBUS/Modbus communications 4 = Communication option card 7 = DWEZ <b>nn: Run command limit status data</b> 00: No limit status. 01: Run command was left on when stopped in the PRG mode 02: Run command was left on when switching from LOCAL to REMOTE operation 03: Waiting for soft charge bypass contactor after power up (Uv or Uv1 flashes after 10 s) 04: Waiting for “Run command prohibited” time period to end 05: Fast Stop (digital input, digital operator) 06: b1-17 (Run command given at power-up) 07: During baseblock while coast to stop with timer 08: Frequency reference is below minimal reference during baseblock 09: Waiting for Enter command	No signal output available	–
U4-22 (7DE)	MEMOBUS/Modbus Communications Reference	<b>All Modes</b> Displays the drive control data set by MEMOBUS/Modbus communications register no. 0001H as a four-digit hexadecimal number.	No signal output available	–

## A.15 U: Monitors

No. (Addr. Hex)	Name	Description	Analog Output Level	Unit
U4-23 (7DF)	Communication Option Card Reference	<b>All Modes</b> Displays drive control data set by an option card as a four-digit hexadecimal number.	No signal output available	–
U4-32 (7FB)	Motor Temperature (NTC)	<b>All Modes</b> Displays the motor temperature (NTC). U4-32 will display “20 °C” when a multi-function analog input is not set for motor thermistor input (H1-□□ = 17H).	No signal output available	°C
U4-35 (1042)	UV Alarm Location Monitor	<b>All Modes</b> Displays the module where the UV alarm occurred as a binary number. Bit 0: Axis 1 Bit 1: Axis 2 Bit 2: Axis 3 Bit 3: Axis 4 Bit 4: Axis 5	No signal output available	–
U4-36 (1043)	OV Alarm Location Monitor	<b>All Modes</b> Displays the module where the OV alarm occurred as a binary number. Bit 0: Axis 1 Bit 1: Axis 2 Bit 2: Axis 3 Bit 3: Axis 4 Bit 4: Axis 5	No signal output available	–
U4-37 (1044)	oH Alarm Location Monitor	<b>All Modes</b> Displays the module where the oH alarm occurred as a binary number. Bit 0: Axis 1 Bit 1: Axis 2 Bit 2: Axis 3 Bit 3: Axis 4 Bit 4: Axis 5  <b>Note:</b> This parameter is only available in models CIMR-A□4A0930 and 4A1200.	No signal output available	–
U4-38 (1045)	FAn Alarm Location Monitor	<b>All Modes</b> Displays the module where the FAn alarm occurred as a binary number. Bit 0: Axis 1 Bit 1: Axis 2 Bit 2: Axis 3 Bit 3: Axis 4 Bit 4: Axis 5  <b>Note:</b> This parameter is only available in models CIMR-A□4A0930, 4A1200 and A1000 HHP.	No signal output available	–
U4-39 (1046)	voF Alarm Location Monitor	<b>All Modes</b> Displays the module where the voF alarm occurred as a binary number. Bit 0: Axis 1 Bit 1: Axis 2 Bit 2: Axis 3 Bit 3: Axis 4 Bit 4: Axis 5  <b>Note:</b> This parameter is only available in models CIMR-A□4A0930, 4A1200 and A1000 HHP.	No signal output available	–
U4-41 (7FE)	UnbC Current Max Location Monitor	<b>All Modes</b> Displays the maximum UnbC current detected. Bit 0: Axis 1 Bit 1: Axis 2 Bit 2: Axis 3 Bit 3: Axis 4 Bit 4: Axis 5	No signal output available	0.10%

<1> When reading the value of this monitor via MEMOBUS/Modbus, a value of 8192 is equal to 100% of the drive rated output current.

<2> The unit is 1 A in models CIMR-A□4A0930 and 4A1200.

◆ U5: PID Monitors

No. (Addr. Hex)	Name	Description	Analog Output Level	Unit
U5-01 (57)	PID Feedback	<b>All Modes</b> Displays the PID feedback value.	10 V: 100%	0.01%
U5-02 (63)	PID Input	<b>All Modes</b> Displays the amount of PID input (deviation between PID setpoint and feedback).	10 V: 100%	0.01%
U5-03 (64)	PID Output	<b>All Modes</b> Displays PID control output.	10 V: 100%	0.01%
U5-04 (65)	PID Setpoint	<b>All Modes</b> Displays the PID setpoint.	10 V: 100%	0.01%
U5-05 (7D2)	PID Differential Feedback	<b>All Modes</b> Displays the 2nd PID feedback value if differential feedback is used (H3-□□ = 16).	10 V: 100%	0.01%
U5-06 (7D3)	PID Adjusted Feedback	<b>All Modes</b> Displays the difference of both feedback values if differential feedback is used (U5-01 - U5-05). If differential feedback is not used, then U5-01 and U5-06 will be the same.	10 V: 100%	0.01%

◆ U6: Operation Status Monitors

No. (Addr. Hex)	Name	Description	Analog Output Level	Unit
U6-01 (51)	Motor Secondary Current (Iq)	<b>All Modes</b> Displays the value of the motor secondary current (Iq). Motor rated secondary current is 100%.	10 V: Motor secondary rated current	0.1%
U6-02 (52)	Motor Excitation Current (Id)	<input type="checkbox"/> V/f <input type="checkbox"/> V/f w PG <input checked="" type="checkbox"/> OLV <input checked="" type="checkbox"/> CLV <input checked="" type="checkbox"/> OLV/PM <input checked="" type="checkbox"/> AOLV/PM <input checked="" type="checkbox"/> CLV/PM Displays the value calculated for the motor excitation current (Id). Motor rated secondary current is 100%.	10 V: Motor secondary rated current	0.1%
U6-03 (54)	ASR Input	<input type="checkbox"/> V/f <input checked="" type="checkbox"/> V/f w PG <input type="checkbox"/> OLV <input checked="" type="checkbox"/> CLV <input type="checkbox"/> OLV/PM <input checked="" type="checkbox"/> AOLV/PM <input checked="" type="checkbox"/> CLV/PM	10 V: Max frequency	0.01%
U6-04 (55)	ASR Output	Displays the input and output values when using ASR control.	10 V: Motor secondary rated current	
U6-05 (59)	Output Voltage Reference (Vq)	<input type="checkbox"/> V/f <input type="checkbox"/> V/f w PG <input checked="" type="checkbox"/> OLV <input checked="" type="checkbox"/> CLV <input checked="" type="checkbox"/> OLV/PM <input checked="" type="checkbox"/> AOLV/PM <input checked="" type="checkbox"/> CLV/PM Output voltage reference (Vq) for the q-Axis.	10 V: 400 Vrms < >	0.1 Vac
U6-06 (5A)	Output Voltage Reference (Vd)	<input type="checkbox"/> V/f <input type="checkbox"/> V/f w PG <input checked="" type="checkbox"/> OLV <input checked="" type="checkbox"/> CLV <input checked="" type="checkbox"/> OLV/PM <input checked="" type="checkbox"/> AOLV/PM <input checked="" type="checkbox"/> CLV/PM Output voltage reference (Vd) for the d-Axis.	10 V: 400 Vrms < >	0.1 Vac
U6-07 (5F)	q-Axis ACR Output	<input type="checkbox"/> V/f <input type="checkbox"/> V/f w PG <input checked="" type="checkbox"/> OLV <input checked="" type="checkbox"/> CLV <input type="checkbox"/> OLV/PM <input checked="" type="checkbox"/> AOLV/PM <input checked="" type="checkbox"/> CLV/PM Displays the output value for current control relative to motor secondary current (q-Axis).	10 V: 400 Vrms < >	0.1%
U6-08 (60)	d-Axis ACR Output	<input type="checkbox"/> V/f <input type="checkbox"/> V/f w PG <input checked="" type="checkbox"/> OLV <input checked="" type="checkbox"/> CLV <input type="checkbox"/> OLV/PM <input checked="" type="checkbox"/> AOLV/PM <input checked="" type="checkbox"/> CLV/PM Displays the output value for current control relative to motor secondary current (d-Axis).	110 V: 400 Vrms < >	0.1%
U6-18 (7CD)	Speed Detection PG1 Counter	<b>All Modes</b> Monitors the number of pulses for speed detection (PG1).	10 V: 65536	1 pulse
U6-19 (7E5)	Speed Detection PG2 Counter	<b>All Modes</b> Monitors the number of pulses for speed detection (PG2).	10 V: 65536	1 pulse

## A.15 U: Monitors

No. (Addr. Hex)	Name	Description	Analog Output Level	Unit
U6-20 (7D4)	Frequency Reference Bias (Up/Down 2)	<b>All Modes</b> Displays the bias value used to adjust the frequency reference.	10 V: Max frequency	0.1%
U6-21 (7D5)	Offset Frequency	<b>All Modes</b> Displays the frequency added to the main frequency reference.	–	0.1%
U6-22 (62)	Zero Servo Pulse Movement	<input type="radio"/> V/f <input type="radio"/> V/f w PG <input type="radio"/> OLV <input checked="" type="radio"/> CLV <input type="radio"/> OLV/PM <input type="radio"/> AOLV/PM <input checked="" type="radio"/> CLV/PM Displays how far the rotor has moved from its last position in PG pulses (multiplied by 4).	10 V: No. of pulses per revolution	1
U6-25 (6B)	Feedback Control Output	<input type="radio"/> V/f <input type="radio"/> V/f w PG <input type="radio"/> OLV <input checked="" type="radio"/> CLV <input type="radio"/> OLV/PM <input type="radio"/> AOLV/PM <input checked="" type="radio"/> CLV/PM Output monitor for the ASR speed loop.	10 V: Motor secondary rated current	0.01%
U6-26 (6C)	Feed Forward Control Output	<input type="radio"/> V/f <input type="radio"/> V/f w PG <input type="radio"/> OLV <input checked="" type="radio"/> CLV <input type="radio"/> OLV/PM <input type="radio"/> AOLV/PM <input checked="" type="radio"/> CLV/PM Output monitor for Feed Forward control.	10 V: Motor secondary rated current	0.01%
U6-30 (7A)	Magnetic Flux Reference	<input type="radio"/> V/f <input type="radio"/> V/f w PG <input type="radio"/> OLV <input checked="" type="radio"/> CLV <input type="radio"/> OLV/PM <input type="radio"/> AOLV/PM <input checked="" type="radio"/> CLV/PM Displays the Magnetic Flux reference as a percent of total flux.	10 V: 100%	0.01%

<1> Values shown are specific to 400 V class drives. Multiply the value by 1.4375 for 575 V class drives. Multiply the value by 1.725 for 690 V class drives.

## ◆ U8: DriveWorksEZ Monitors

No. (Addr. Hex)	Name	Description	Analog Output Level	Unit
U8-01 to U8-10 (1950 to 1959)	DriveWorksEZ Custom Monitor 1 to 10	<b>All Modes</b> DriveWorksEZ Custom Monitor 1 to 10	10 V: 100%	0.01%
U8-11 to U8-13 (195A to 195C)	DriveWorksEZ Version Control Monitor 1 to 3	<b>All Modes</b> DriveWorksEZ Version Control Monitor 1 to 3	No signal output available	–



## A.16 Control Mode Dependent Parameter Default Values

The tables below list parameters that depend on the control mode selection (A1-02 for motor 1, E3-01 for motor 2). Changing the control mode initializes these parameters to the values shown here.

### ◆ A1-02 (Motor 1 Control Mode) Dependent Parameters

Table A.3 A1-02 (Motor 1 Control Mode) Dependent Parameters and Default Values

No.	Name	Setting Range	Resolution	Control Modes (A1-02)			
				V/f (0)	V/f w/PG (1)	OLV (2)	CLV (3)
b2-01	DC Injection Braking Start Frequency	0.0 to 10.0	0.1 Hz	0.5	0.5	0.5	0.5
b2-04	DC Injection Braking Time at Stop	0.00 to 10.00	0.01 s	0.50	0.50	0.50	0.50
b3-01	Speed Search Selection at Start	0 to 1	–	0	1	0	1
b3-02	Speed Search Deactivation Current	0 to 200	1%	120	–	100	–
b3-14	Bi-Directional Speed Search Selection	0 to 1	1	1	0	1	1
b5-15	PID Sleep Function Start Level	0.0 to 400.0 <1>	0.1	0.0 Hz	0.0 Hz	0.0 Hz	0.0 Hz
b6-01	Dwell Reference at Start	0.0 to 400.0 <1>	0.1	0.0 Hz	0.0 Hz	0.0 Hz	0.0 Hz
b6-03	Dwell Reference at Stop	0.0 to 400.0 <1>	0.1	0.0 Hz	0.0 Hz	0.0 Hz	0.0 Hz
b8-01	Energy Saving Control Selection	0 to 1	–	0	0	0	0
b8-02	Energy Saving Gain	0.0 to 10.0	0.1	–	–	0.7	1.0
b8-03	Energy Saving Control Filter Time Constant	0.00 to 10.00	0.01 s	–	–	0.50 <2>	0.01 <2>
C1-11	Accel/Decel Time Switching Frequency	0.0 to 400.0 <1>	0.1	0.0 Hz	0.0 Hz	0.0 Hz	0.0 Hz
C2-01	S-Curve Time at Acceleration Start	0.00 to 10.00	0.01 s	0.20	0.20	0.20	0.20
C3-01	Slip Compensation Gain	0.0 to 2.5	0.1	0.0	–	1.0	1.0
C3-02	Slip Compensation Primary Delay Time	0 to 10000	1 ms	2000	–	200	–
C4-01	Torque Compensation Gain	0.00 to 2.50	0.01	1.00	1.00	1.00	–
C4-02	Torque Compensation Primary Delay Time	0 to 10000	1 ms	200 <3>	200 <3>	20	–
C5-01	ASR Proportional Gain 1	0.00 to 300.00	0.01	–	0.20	–	20.00
C5-02	ASR Integral Time 1	0.000 to 10.000	0.001 s	–	0.200	–	0.500
C5-03	ASR Proportional Gain 2	0.00 to 300.00	0.01	–	0.02	–	20.00
C5-04	ASR Integral Time 2	0.000 to 10.000	0.001 s	–	0.050	–	0.500
C5-06	ASR Primary Delay Time Constant	0.000 to 0.500	0.001 s	–	–	–	0.004
C5-07	ASR Gain Switching Frequency	0.0 to 400.0 <1>	0.1	0.0 Hz	0.0 Hz	0.0 Hz	0.0 Hz
C6-02	Carrier Frequency Selection	1 to F	–	7 <4>	7 <4>	7 <4>	7
d3-01	Jump Frequency 1	0.0 to 400.0 <1>	0.1	0.0 Hz	0.0 Hz	0.0 Hz	0.0 Hz
d3-02	Jump Frequency 2	0.0 to 400.0 <1>	0.1	0.0 Hz	0.0 Hz	0.0 Hz	0.0 Hz
d3-03	Jump Frequency 3	0.0 to 400.0 <1>	0.1	0.0 Hz	0.0 Hz	0.0 Hz	0.0 Hz
d3-04	Jump Frequency Width	0.0 to 20.0 <5>	0.1	1.0 Hz	1.0 Hz	1.0 Hz	1.0 Hz
d5-02	Torque Reference Delay Time	0 to 1000	1 ms	–	–	–	0
E1-04	Maximum Output Frequency	40.0 to 400.0	0.1 Hz	60.0	60.0	60.0	60.0
E1-05	Maximum Voltage	0.0 to 510.0 <6>	0.1 V	575 <7>	575 <7>	575	575
E1-06	Base Frequency	0.0 to 400.0	0.1 Hz	60.0	60.0	60.0	60.0
E1-07	Middle Output Frequency	0.0 to 400.0	0.1 Hz	3.0	3.0	3.0	3.0
E1-08	Middle Output Frequency Voltage	0.0 to 255.0 <6>	0.1 V	15.0 <7>	15.0 <7>	15.0	15.0
E1-09	Minimum Output Frequency	0.0 to 400.0	0.1 Hz	1.5	1.5	0.5	0.0
E1-10	Minimum Output Frequency Voltage	0.0 to 255.0 <6>	0.1 V	9.0	9.0	2.0	0.0
F1-01	PG 1 Pulses Per Revolution	0 to 60000	1 ppr	600	600	600	600
F1-05	PG 1 Rotation Selection	0 to 1	–	0	0	0	0
F1-09	Overspeed Detection Delay Time	0.0 to 2.0	0.1 s	–	1.0	–	0.0
L1-01	Motor Overload Protection Selection	0 to 4	–	1	1	1	1
L3-20	DC Bus Voltage Adjustment Gain	0.00 to 5.00	0.01	1.00	1.00	0.30	0.30
L3-21	Accel/Decel Rate Calculation Gain	0.10 to 10.00	0.01	1.00	1.00	1.00	1.00

## A.16 Control Mode Dependent Parameter Default Values

No.	Name	Setting Range	Resolution	Control Modes (A1-02)			
				V/f (0)	V/f w/Pg (1)	OLV (2)	CLV (3)
L4-01	Speed Agreement Detection Level	0.0 to 400.0 <1>	0.1	0.0 Hz	0.0 Hz	0.0 Hz	0.0 Hz
L4-02	Speed Agreement Detection Width	0.0 to 20.0	0.1 Hz	2.0	2.0	2.0	2.0
L4-03	Speed Agreement Detection Level (+/-)	-400.0 to 400.0 <8>	0.1	0.0 Hz	0.0 Hz	0.0 Hz	0.0 Hz
L4-04	Speed Agreement Detection Width (+/-)	0.0 to 20.0	0.1 Hz	2.0	2.0	2.0	2.0
L8-38	Carrier Frequency Reduction Selection	0 to 2	1	<4>	<4>	<4>	<4>
L8-40	Carrier Frequency Reduction Off Delay Time	0.00 to 2.00	0.01 s	0.50	0.50	0.50	0.50
o1-03	Digital Operator Display Selection	0 to 3	1	0	0	0	0
o1-04	V/f Pattern Display Unit	0 to 1	1	—	—	—	0

- <1> In AOLV/PM and CLV/PM control modes, the setting units and range are expressed as a percentage (0.0 to 100.0%) instead of in Hz.
- <2> This setting value depends on a Maximum Applicable Motor Capacity in models CIMR-A□2A0250 to 2A0415, CIMR-A□4A0139 to 4A1200, A1000 HHP, and CIMR-A□5A0099 to 5A0242: 2.00 in Open Loop Vector Control, 0.05 in Closed Loop Vector Control.
- <3> This setting value depends on a Maximum Applicable Motor Capacity: 1000 s in models CIMR-A□2A0138 to 2A0415, CIMR-A□4A0139 to 4A1200, A1000 HHP, and CIMR-A□5A0099 to 5A0242
- <4> Default setting is dependent on parameter C6-01, Drive Duty Selection.
- <5> In AOLV/PM and CLV/PM control modes, the setting units and range are expressed as a percentage (0.0 to 40.0%) instead of in Hz.
- <6> Values shown are specific to 400 V class drives. Multiply the value by 1.4375 for 575 V class drives. Multiply the value by 1.725 for 690 V class drives.
- <7> This setting value depends on a Maximum Applicable Motor Capacity and V/f pattern selection in parameter E1-03.
- <8> In AOLV/PM and CLV/PM control modes, the setting units and range are expressed as a percentage (-100.0 to 100.0%) instead of in Hz.

◆ E3-01 (Motor 2 Control Mode) Dependent Parameters

Table A.4 E3-01 (Motor 2 Control Mode) Dependent Parameters and Default Values

No.	Name	Setting Range	Resolution	Control Modes (E3-01)			
				V/f (0)	V/f w/Pg (1)	OLV (2)	CLV (3)
C3-21	Motor 2 Slip Compensation Gain	0.0 to 2.5	0.1	0.0	–	1.0	1.0
C3-22	Motor 2 Slip Compensation Primary Delay Time	0 to 10000	1 ms	2000	–	200	–
C5-21	Motor 2 ASR Proportional Gain 1	0.00 to 300.00	0.01	–	0.20	–	20.00
C5-22	Motor 2 ASR Integral Time 1	0.000 to 10.000	0.001 s	–	0.200	–	0.500
C5-23	Motor 2 Proportional Gain 2	0.00 to 300.00	0.01	–	0.02	–	20.00
C5-24	Motor 2 ASR Integral Time 2	0.000 to 10.000	0.001 s	–	0.050	–	0.500
C5-26	Motor 2 Carrier Frequency Selection	1 to F	–	7 <1>	7 <1>	7 <1>	7 <1>
E3-04	Motor 2 Maximum Output Frequency	40.0 to 400.0	0.1 Hz	60.0	60.0	60.0	60.0
E3-05	Motor 2 Maximum Output Voltage <2>	0.0 to 510.0	0.2 V	400.0	400.0	400.0	400.0
E3-06	Motor 2 Base Frequency	0.0 to 400.0	0.1 Hz	60.0	60.0	60.0	60.0
E3-07	Motor 2 Mid Output Frequency	0.0 to 400.0	0.1 Hz	3.0	3.0	3.0	0.0
E3-08	Motor 2 Mid Output Frequency Voltage <2>	0.0 to 510.0	0.2 V	30.0	30.0	22.0	0.0
E3-09	Motor 2 Minimum Output Frequency	0.0 to 400.0	0.1 Hz	1.5	1.5	0.5	0.0
E3-10	Motor 2 Minimum Output Voltage <2>	0.0 to 510.0	0.2 V	18.0	18.0	4.0	0.0

<1> Default setting is determined by parameters o2-04, Drive Model Selection, and C6-01, Drive Duty Selection.

<2> Values shown here are specific to 400 V class drives. Multiply the values by 1.4375 for 575 V class drives. Multiply the values by 1.725 for 690 V class drives.

## A.17 V/f Pattern Default Values

The following table shows the V/f pattern setting default values depending on the control mode (A1-02) and the V/f pattern selection (E1-03 in V/f Control) for all HHP models:

- 400 V Class 414 A to 2000 A Heavy Duty, 466 A to 2250 A Normal Duty,
- 575 V Class 414 A to 2000 A Heavy Duty, 466 A to 2250 A Normal Duty,
- 690 V Class 414 A to 2000 A Heavy Duty, 466 A to 2250 A Normal Duty.

**Table A.5 E1-03 V/f Pattern Settings for Drive Capacity:**

No.	Unit	V/f Control																OLV	CLV
		0	1	2	3	4	5	6	7	8	9	A	B	C	D	E	F <1>		
E1-03	-	0	1	2	3	4	5	6	7	8	9	A	B	C	D	E	F <1>	OLV	CLV
E1-04	Hz	50.0	60.0	60.0	72.0	50.0	50.0	60.0	60.0	50.0	50.0	60.0	60.0	90.0	120.0	180.0	60.0	60.0	60.0
E1-05 <3>	V	400.0	400.0	400.0	400.0	400.0	400.0	400.0	400.0	400.0	400.0	400.0	400.0	400.0	400.0	400.0	460.0	460.0	460.0
E1-06	Hz	50.0	60.0	50.0	60.0	50.0	50.0	60.0	60.0	50.0	50.0	60.0	60.0	60.0	60.0	60.0	60.0	60.0	60.0
E1-07	Hz	2.5	3.0	3.0	3.0	25.0	25.0	30.0	30.0	2.5	2.5	3.0	3.0	3.0	3.0	3.0	3.0	3.0	0.0
E1-08 <3>	V	24.0	24.0	24.0	24.0	70.0	100.0	70.0	100.0	30.0	40.0	30.0	40.0	24.0	24.0	24.0	27.6	25.4	0.0
E1-09	Hz	1.3	1.5	1.5	1.5	1.3	1.3	1.5	1.5	1.3	1.3	1.5	1.5	1.5	1.5	1.5	1.5	0.5	0.0
E1-10 <3>	V	12.0	12.0	12.0	12.0	10.0	12.0	10.0	12.0	14.0	18.0	14.0	22.0	12.0	12.0	12.0	13.8	4.6	0.0

<1> This value determines the default values for E1-04 through E1-10 (E3-04 through E3-10 for motor 2).

<3> Values shown here are specific to 400 V class drives. Multiply the values by 1.4375 for 575 V class drives. Multiply the values by 1.725 for 690 V class drives.

## A.18 Defaults by Drive Model and Duty Rating ND/HD

The following tables show parameters and default settings that change with the drive model selection (o2-04) and drive duty selection (C6-01).

**Table A.6 400 V Class Drives Default Settings by Drive Model Selection and ND/HD Settings**

Constant No.	Name	Unit	Default Settings									
			4200		4400		4600		4800		410C	
–	Model Type		HD	ND	HD	ND	HD	ND	HD	ND	HD	ND
<b>C6-01</b>	<b>ND/HD Select</b>	–	<b>177 (B1H)</b>	<b>177 (B1H)</b>	<b>178 (B2H)</b>	<b>178 (B2H)</b>	<b>179 (B3H)</b>	<b>179 (B3H)</b>	<b>180 (B4H)</b>	<b>180 (B4H)</b>	<b>181 (B5H)</b>	<b>181 (B5H)</b>
<b>o2-04</b>	<b>Drive Model Selection</b>	–	<b>414.0</b>	<b>466.0</b>	<b>800.0</b>	<b>900.0</b>	<b>1200.0</b>	<b>1350.0</b>	<b>1600.0</b>	<b>1800.0</b>	<b>2000.0</b>	<b>2250.0</b>
	<b>Inverter Rated Current</b>	<b>A</b>										
E2-11 (E4-11)	Motor Rated Power	KW	200.00	250.00	400.0	500.0	600.0	750.0	800.0	1000.0	1000.0	1250.0
b3-04	V/f Gain during Speed Search	%	60	60	60	60	60	60	60	60	60	60
b3-06	Output Current 1 during Speed Search	–	0.7	0.7	0.7	0.7	0.7	0.7	0.7	0.7	0.7	0.7
E2-01 (E4-01)	Motor Rated Current	A	400.0	400.0	800.0	800.0	1200.0	1200.0	1800.0	1800.0	2000.0	2500.0
E2-02 (E4-02)	Motor Rated Slip	Hz	0.50	0.50	0.50	0.50	0.50	0.50	0.50	0.50	0.50	0.50
E2-03 (E4-03)	Motor No-Load Current	A	80.0	80.0	160.0	160.0	240.0	240.0	360.0	360.0	400.0	500.0
E2-05 (E4-05)	Motor Line-to-Line Resistance	mΩ	12.000	12.000	8.500	8.500	7.000	7.000	6.000	6.000	5.500	5.000
E2-06 (E4-06)	Motor Leakage Inductance	%	20.0	20.0	20.0	20.0	20.0	20.0	20.0	20.0	20.0	20.0
E2-10 (E4-10)	Motor Iron Loss for Torque Compensation	W	0	0	0	0	0	0	0	0	0	0
L2-02	Momentary Power Loss Ride-Through Time	s	2.0	2.0	2.0	2.0	2.0	2.0	2.0	2.0	2.0	2.0
L2-03	Momentary Power Loss Minimum Baseblk Time	s	2.0	2.0	2.1	2.1	2.1	2.1	2.1	2.1	2.1	2.1
L2-04	Momentary Power Loss Voltage Recovery Time	s	1.0	1.0	1.0	1.0	1.0	1.0	1.0	1.0	1.0	1.0
L8-02	Overheat Alarm Level	°C	125	125	125	125	125	125	125	125	125	125
L8-38	Carrier Frequency Reduction Selection		2	2	2	2	2	2	2	2	2	2

**Table A.7 575 V Class Drives Default Settings by Drive Model Selection and ND/HD Settings**

Constant No.	Name	Unit	Default Settings									
			5300		5600		5900		5C00		5F00	
–	Model Type		HD	ND	HD	ND	HD	ND	HD	ND	HD	ND
<b>C6-01</b>	<b>ND/HD Select</b>	–	<b>225 (E1H)</b>	<b>225 (E1H)</b>	<b>226 (E2H)</b>	<b>226 (E2H)</b>	<b>227 (E3H)</b>	<b>227 (E3H)</b>	<b>228 (E4H)</b>	<b>228 (E4H)</b>	<b>229 (E5H)</b>	<b>229 (E5H)</b>
<b>o2-04</b>	<b>Drive Model Selection</b>	–	<b>414.0</b>	<b>466.0</b>	<b>800.0</b>	<b>900.0</b>	<b>1200.0</b>	<b>1350.0</b>	<b>1600.0</b>	<b>1800.0</b>	<b>2000.0</b>	<b>2250.0</b>
	<b>Inverter Rated Current</b>	<b>A</b>										
E2-11 (E4-11)	Motor Rated Power	KW	300.0	335.00	600.0	670.0	900.0	1005.0	1200.0	1340.0	1500.0	1675.0
b3-04	V/f Gain during Speed Search	%	80	80	80	80	80	80	80	80	80	80
b3-06	Output Current 1 during Speed Search	–	0.5	0.5	0.5	0.5	0.5	0.5	0.5	0.5	0.5	0.5
E2-01 (E4-01)	Motor Rated Current	A	350.0	350.0	700.0	700.0	1050.0	1050.0	1400.0	1400.0	1750.0	1750.0
E2-02 (E4-02)	Motor Rated Slip	Hz	0.5	0.5	0.5	0.5	0.5	0.5	0.5	0.5	0.5	0.5
E2-03 (E4-03)	Motor No-Load Current	A	70.0	70.0	140.0	140.0	210.0	210.0	280.0	280.0	350.0	350.0
E2-05 (E4-05)	Motor Line-to-Line Resistance	mΩ	14.000	14.000	10.000	10.000	8.000	8.000	7.000	7.000	6.000	6.000

## A.18 Defaults by Drive Model and Duty Rating ND/HD

Constant No.	Name	Unit	Default Settings									
			5300		5600		5900		5C00		5F00	
–	Model Type		HD	ND	HD	ND	HD	ND	HD	ND	HD	ND
<b>C6-01</b>	<b>ND/HD Select</b>	–	HD	ND	HD	ND	HD	ND	HD	ND	HD	ND
<b>o2-04</b>	<b>Drive Model Selection</b>	–	<b>225 (E1H)</b>	<b>225 (E1H)</b>	<b>226 (E2H)</b>	<b>226 (E2H)</b>	<b>227 (E3H)</b>	<b>227 (E3H)</b>	<b>228 (E4H)</b>	<b>228 (E4H)</b>	<b>229 (E5H)</b>	<b>229 (E5H)</b>
	<b>Inverter Rated Current</b>	<b>A</b>	<b>414.0</b>	<b>466.0</b>	<b>800.0</b>	<b>900.0</b>	<b>1200.0</b>	<b>1350.0</b>	<b>1600.0</b>	<b>1800.0</b>	<b>2000.0</b>	<b>2250.0</b>
E2-06 (E4-06)	Motor Leakage Inductance	%	20.0	20.0	20.0	20.0	20.0	20.0	20.0	20.0	20.0	20.0
E2-10 (E4-10)	Motor Iron Loss for Torque Compensation	W	0	0	0	0	0	0	0	0	0	0
L2-02	Momentary Power Loss Ride-Through Time	s	2.0	2.0	2.0	2.0	2.0	2.0	2.0	2.0	2.0	2.0
L2-03	Momentary Power Loss Minimum Baseblk Time	s	2.0	2.0	2.0	2.0	2.0	2.0	2.0	2.0	2.0	2.0
L2-04	Momentary Power Loss Voltage Recovery Time	s	1.5	1.5	1.5	1.5	1.5	1.5	1.5	1.5	1.5	1.5
L8-02	Overheat Alarm Level	°C	130	130	130	130	130	130	130	130	130	130
L8-38	Carrier Frequency Reduction Selection		2	2	2	2	2	2	2	2	2	2

**Table A.8 YAI 690 V Class Drives Default Settings by Drive Model Selection and ND/HD Settings**

Constant No.	Name	Unit	Default Settings									
			Note: 690 V class default values when o2-09 = 1									
–	Model Type		6300		6600		6900		6C00		6F00	
C6-01	ND/HD Select	–	HD	ND	HD	ND	HD	ND	HD	ND	HD	ND
<b>o2-04</b>	<b>Drive Model Selection</b>	–	<b>241 (F1H)</b>	<b>241 (F1H)</b>	<b>242 (F2H)</b>	<b>242 (F2H)</b>	<b>243 (F3H)</b>	<b>243 (F3H)</b>	<b>244 (F4H)</b>	<b>244 (F4H)</b>	<b>245 (F5H)</b>	<b>245 (F5H)</b>
	<b>Inverter Rated Current</b>	<b>A</b>	<b>414.0</b>	<b>466.0</b>	<b>800.0</b>	<b>900.0</b>	<b>1200.0</b>	<b>1350.0</b>	<b>1600.0</b>	<b>1800.0</b>	<b>2000.0</b>	<b>2250.0</b>
E2-11 (E4-11)	Motor Rated Power	KW	300.0	335.00	600.0	670.0	900.0	1005.0	1200.0	1340.0	1500.0	1675.0
b3-04	V/f Gain during Speed Search	%	80	80	80	80	80	80	80	80	80	80
b3-06	Output Current 1 during Speed Search	–	0.5	0.5	0.5	0.5	0.5	0.5	0.5	0.5	0.5	0.5
E2-01 (E4-01)	Motor Rated Current	A	350.0	350.0	700.0	700.0	1050.0	1050.0	1400.0	1400.0	1750.0	1750.0
E2-02 (E4-02)	Motor Rated Slip	Hz	0.50	0.50	0.50	0.50	0.50	0.50	0.50	0.50	0.50	0.50
E2-03 (E4-03)	Motor No-Load Current	A	70.0	70.0	140.0	140.0	210.0	210.0	280.0	280.0	350.0	350.0
E2-05 (E4-05)	Motor Line-to-Line Resistance	mΩ	14.000	14.000	10.000	10.000	8.000	8.000	7.000	7.000	6.000	6.000
E2-06 (E4-06)	Motor Leakage Inductance	%	20.0	20.0	20.0	20.0	20.0	20.0	20.0	20.0	20.0	20.0
E2-10 (E4-10)	Motor Iron Loss for Torque Compensation	W	0	0	0	0	0	0	0	0	0	0
L2-02	Momentary Power Loss Ride-Thru Time	s	2.0	2.0	2.0	2.0	2.0	2.0	2.0	2.0	2.0	2.0
L2-03	Momentary Power Loss Minimum Baseblk Time	s	2.0	2.0	2.0	2.0	2.0	2.0	2.0	2.0	2.0	2.0
L2-04	Momentary Power Loss Voltage Recovery Time	s	1.5	1.5	1.5	1.5	1.5	1.5	1.5	1.5	1.5	1.5
L8-02	Overheat Alarm Level	°C	130	130	130	130	130	130	130	130	130	130
L8-38	Carrier Frequency Reduction Selection	–	2	2	2	2	2	2	2	2	2	2

Table A.9 YEC 690 V Class Drives Default Settings by Drive Model Selection and ND/HD Settings

Constant No.	Name	Unit	Default Settings									
			Note: 690 V class default values when o2-o9 = 0									
–	Model Type		6300		6600		6900		6C00		6F00	
C6-01	ND/HD Select	–	HD	ND	HD	ND	HD	ND	HD	ND	HD	ND
o2-04	Drive Model Selection	–	241 (F1H)	241 (F1H)	242 (F2H)	242 (F2H)	243 (F3H)	243 (F3H)	244 (F4H)	244 (F4H)	245 (F5H)	245 (F5H)
	Inverter Rated Current	A	360.0	414.0	700.0	800.0	1050.0	1200.0	1400.0	1600.0	1750.0	2000.0
E2-11 (E4-11)	Motor Rated Power	KW	300.0	335.0	600.0	670.0	900.0	1005.0	1200.0	1340.0	1500.0	1675.0
b3-04	V/f Gain during Speed Search	%	80	80	80	80	80	80	80	80	80	80
b3-06	Output Current 1 during Speed Search	–	0.5	0.5	0.5	0.5	0.5	0.5	0.5	0.5	0.5	0.5
E2-01 (E4-01)	Motor Rated Current	A	350.0	350.0	700.0	700.0	1050.0	1050.0	1400.0	1400.0	1750.0	1750.0
E2-02 (E4-02)	Motor Rated Slip	Hz	0.5	0.5	0.5	0.5	0.5	0.5	0.5	0.5	0.5	0.5
E2-03 (E4-03)	Motor No-Load Current	A	70.0	70.0	140.0	140.0	210.0	210.0	280.0	280.0	350.0	350.0
E2-05 (E4-05)	Motor Line-to-Line Resistance	mΩ	14.000	14.000	10.000	10.000	8.000	8.000	7.000	7.000	6.000	6.000
E2-06 (E4-06)	Motor Leakage Inductance	%	20.0	20.0	20.0	20.0	20.0	20.0	20.0	20.0	20.0	20.0
E2-10 (E4-10)	Motor Iron Loss for Torque Compensation	W	0	0	0	0	0	0	0	0	0	0
L2-02	Momentary Power Loss Ride-Through Time	s	2.0	2.0	2.0	2.0	2.0	2.0	2.0	2.0	2.0	2.0
L2-03	Momentary Power Loss Minimum Baseblk Time	s	2.0	2.0	2.0	2.0	2.0	2.0	2.0	2.0	2.0	2.0
L2-04	Momentary Power Loss Voltage Recovery Time	s	1.5	1.5	1.5	1.5	1.5	1.5	1.5	1.5	1.5	1.5
L8-02	Overheat Alarm Level	°C	130	130	130	130	130	130	130	130	130	130
L8-38	Carrier Frequency Reduction Selection	–	2	2	2	2	2	2	2	2	2	2

**This Page Intentionally Blank**



# Appendix: B

## **MEMOBUS/Modbus Communications**

---

<b>B.1</b>	<b>MEMOBUS/MODBUS CONFIGURATION.....</b>	<b>314</b>
<b>B.2</b>	<b>COMMUNICATION SPECIFICATIONS.....</b>	<b>315</b>
<b>B.3</b>	<b>CONNECTING TO A NETWORK.....</b>	<b>316</b>
<b>B.4</b>	<b>MEMOBUS/MODBUS SETUP PARAMETERS.....</b>	<b>319</b>
<b>B.5</b>	<b>DRIVE OPERATIONS BY MEMOBUS/MODBUS.....</b>	<b>322</b>
<b>B.6</b>	<b>COMMUNICATIONS TIMING.....</b>	<b>323</b>
<b>B.7</b>	<b>MESSAGE FORMAT.....</b>	<b>324</b>
<b>B.8</b>	<b>MESSAGE EXAMPLES.....</b>	<b>326</b>
<b>B.9</b>	<b>MEMOBUS/MODBUS DATA TABLE.....</b>	<b>328</b>
<b>B.10</b>	<b>ENTER COMMAND.....</b>	<b>344</b>
<b>B.11</b>	<b>COMMUNICATION ERRORS.....</b>	<b>345</b>
<b>B.12</b>	<b>SELF-DIAGNOSTICS.....</b>	<b>346</b>

### B.1 MEMOBUS/Modbus Configuration

Drives can be controlled from a PLC or other master device via serial communications using the MEMOBUS/Modbus protocol. MEMOBUS/Modbus communications can be configured using one master (PLC) and up to 31 slaves. The drive has slave functionality only, and serial communication is normally initiated from the master and responded to by the slaves.

The master performs serial communications with only one slave at a time. The address or node for each slave must be set beforehand so that the master can communicate with the slave at that address. A slave that receives a command from the master will perform the specified function and then send a response back to the master.

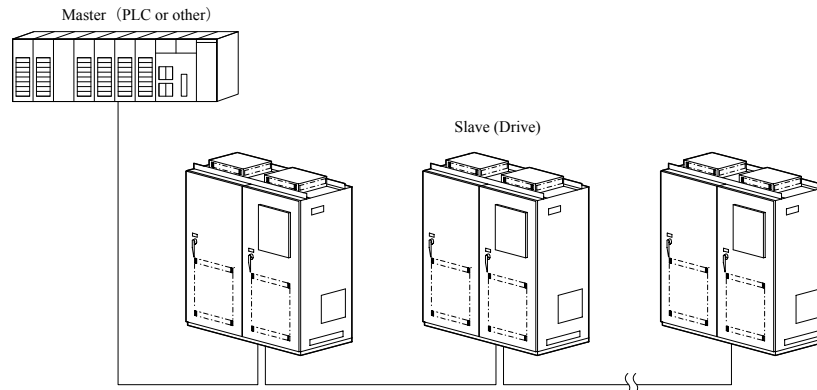

Figure B.1 Connecting Multiple Drives to a PLC

## B.2 Communication Specifications

MEMOBUS/Modbus specifications appear in the following table:

Item	Specifications	
Interface	RS-422, RS-485	
Communications Cycle	Asynchronous (Start-stop synchronization)	
Communication Parameters	Communication Speeds Available	1.2; 2.4; 4.8; 9.6; 19.2; 38.4; 57.6; 76.8; 115.2 kbps
	Data length	8-bit (fixed)
	Parity	Select even, odd, or none
	Stop bit	1-bit (fixed)
Protocol	MEMOBUS/Modbus (using RTU mode only)	
Max Number of Slaves	31 drives	

### B.3 Connecting to a Network

This section explains how to connect the drive to a MEMOBUS/Modbus network and the network termination required for a connection.

#### ◆ Network Cable Connection

Follow the instructions below to connect the drive to a MEMOBUS/Modbus network.

1. With the power shut off, connect the communications cable to the drive and the master. Use terminals TB5 for MEMOBUS/Modbus.

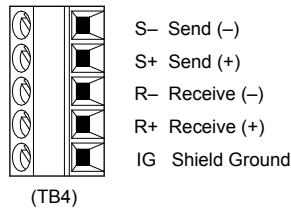

**Figure B.2 Serial Communications Cable Connection Terminals (TB4)**

**Note:** Separate the communications cables from the main circuit cables and other wiring and power cables. Use shielded cables for the communications cables, and properly shielded clamps to prevent problems with noise. When using RS-485 communications, connect S+ to R+, and S- to R- as shown in the RS-485 diagram.

2. Check or set the termination resistor selection at all slaves. Use the description in [Network Termination](#) on page [317](#) for slaves that are A1000 HHP drives.
3. Switch the power on.
4. Set the parameters needed for serial communications (H5-01 through H5-12) using the digital operator.
5. Shut the power off and wait until the display on the digital operator goes out completely.
6. Turn the power back on.
7. The drive is now ready to begin communicating with the master.

#### ◆ Wiring Diagram for Multiple Connections

[Figure B.3](#) and [Figure B.4](#) explain the wiring diagrams for multiple connections using MEMOBUS/Modbus communication.

## ■ RS-485 Interface

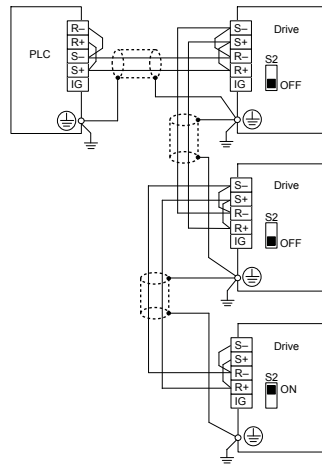

Figure B.3 RS-485 Interface

- Note:**
1. Turn on the DIP switch on the drive that is located at the end of the network. All other slave devices must have this DIP switch set to the OFF position.
  2. Set H5-07 to 1 when using the RS-485 interface.

## ■ RS-422 Interface

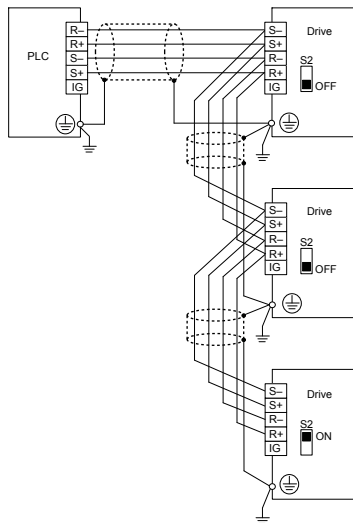

Figure B.4 RS-422 Interface

## ◆ Network Termination

The two ends of the MEMOBUS/Modbus network line have to be terminated. The drive has a built in termination resistor that can be enabled or disabled using DIP switch S2. If a drive is located at the end of a network line, enable the termination resistor by setting DIP switch S2 to the ON position. Disable the termination resistor on all slaves that are not located at the network line end.

### B.3 Connecting to a Network

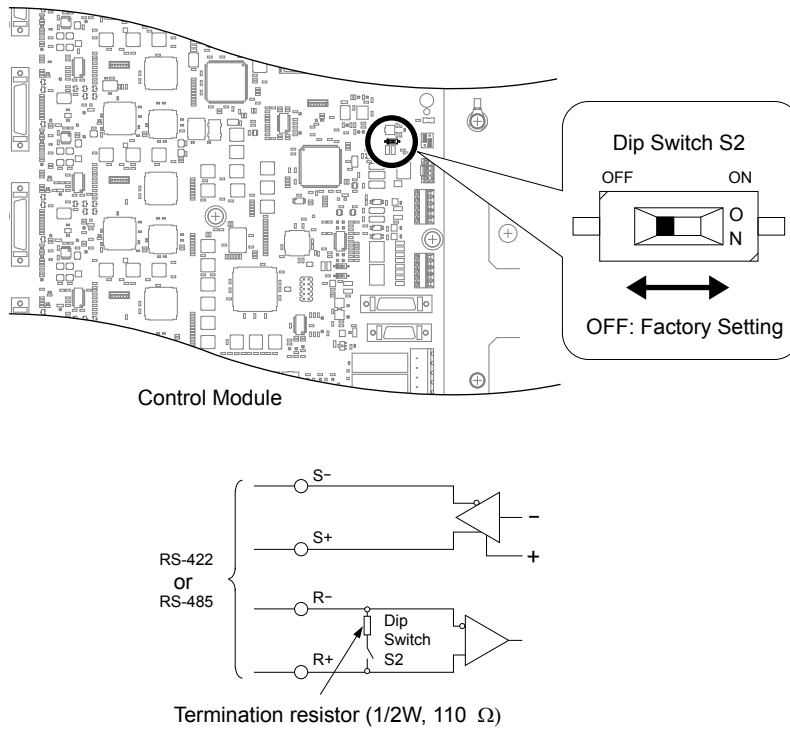

Figure B.5 MEMOBUS/Modbus communication terminal and S2 DIP switch

## B.4 MEMOBUS/Modbus Setup Parameters

### ◆ MEMOBUS/Modbus Serial Communication

This section describes parameters necessary to set up MEMOBUS/Modbus communications.

#### ■ H5-01: Drive Slave Address

Sets the drive slave address used for communications.

**Note:** Cycle the power after changing this parameter to enable the new setting.

No.	Name	Setting Range	Default
H5-01	Drive Slave Address		1FH

#### ■ H5-02: Communication Speed Selection

Sets the MEMOBUS/Modbus communications speed.

**Note:** Cycle the power after changing this parameter to enable the new setting.

No.	Name	Setting Range	Default
H5-02	Communication Speed Selection	0 to 8	3

H5-02	Communication Speed	H5-02	Communication Speed
0	1200 bps	5	38400 bps
1	2400 bps	6	57600 bps
2	4800 bps	7	76800 bps
3	9600 bps	8	115200 bps
4	19200 bps		

#### ■ H5-03: Communication Parity Selection

Sets the parity used for communications.

**Note:** Cycle the power after changing this parameter to enable the new setting.

No.	Name	Setting Range	Default
H5-03	Communication Parity Selection	0 to 2	0

**Setting 0: No parity**

**Setting 1: Even parity**

**Setting 2: Odd parity**

#### ■ H5-04: Stopping Method after Communication Error

Selects the stopping method after a communications error (CE) has occurred.

No.	Name	Setting Range	Default
H5-04	Stopping Method after CE	0 to 3	3

**Setting 0: Ramp to stop (uses the deceleration time currently enabled)**

**Setting 1: Fast Stop (uses the deceleration time in C1-09)**

**Setting 2: Coast to stop**

**Setting 3: Alarm only (continue operation)**

#### ■ H5-05: Communication Fault Detection Selection

Enables or disables the CE detection for communications.

No.	Name	Setting Range	Default
H5-05	Communication Fault Detection Selection	0 or 1	1

**Setting 0: Disabled**

No communication error detection. The drive continues operation.

## B.4 MEMOBUS/Modbus Setup Parameters

### Setting 1: Enabled

If the drive does not receive data from the master for longer than the time set to H5-09, then a CE fault will be triggered and the drive will operate as determined by parameter H5-04.

### ■ H5-06: Drive Transmit Wait Time

Sets the time the drive waits after receiving data from a master until responding data.

No.	Name	Setting Range	Default
H5-06	Drive Transmit Wait Time	5 to 65 ms	5 ms

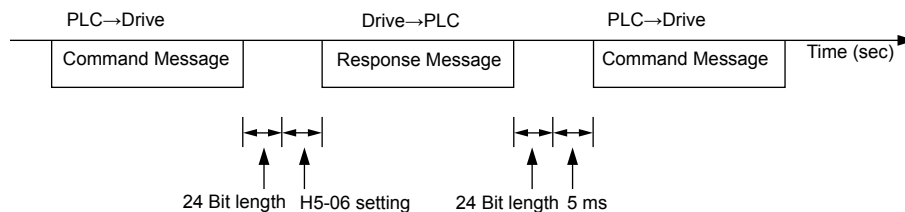

Figure B.6 Drive Transmit Wait Time Setting

### ■ H5-07: RTS Control Selection

Enables or disables RTS control.

No.	Name	Setting Range	Default
H5-07	RTS Control Selection	0, 1	1

#### Setting 0: Disabled. RTS is always on.

Use this setting with point-to-point or multi-drop RS-422 communications.

#### Setting 1: Enabled. RTS switches while sending.

Use this setting when using RS-485 signals for communications or when using the RS-422 signals for point-to-point communications.

### ■ H5-09: CE Detection Time

Sets the time the communications must be lost before the drive triggers a CE fault.

No.	Name	Setting Range	Default
H5-09	CE Detection Time	0.0 to 10.0 s	2.0 s

### ■ H5-10: Unit Selection for MEMOBUS/Modbus Register 0025H

Sets the unit for the output voltage monitor value in MEMOBUS/Modbus register 0025H.

No.	Name	Setting Range	Default
H5-10	Unit Selection for MEMOBUS/Modbus Register 0025H	0, 1	0

Setting 0: 0.1 V units

Setting 1: 1 V units

### ■ H5-11: Communications Enter Function Selection

Selects whether an Enter command is necessary to change parameter values via MEMOBUS/Modbus communications. *Refer to Enter Command on page 344.*



No.	Name	Setting Range	Default
H5-11	Communications Enter Function Selection	0 or 1	0

**Setting 0: Enter command necessary**

Parameter changes become effective after an Enter command. An Enter command must only be sent after the last parameter change, not for each single parameter.

**Setting 1: Enter command not necessary**

Parameter value changes become effective immediately without the need to send an Enter command.

■ **H5-12: Run Command Method Selection**

Selects the type of sequence used when the Run command source is set to MEMOBUS/Modbus communications (b1-02, b1-16 = 2).

No.	Name	Setting Range	Default
H5-12	Run Command Method Selection	0 or 1	0

**Setting 0: FWD/Stop, REV/Stop**

Setting bit 0 of MEMOBUS/Modbus register will start and stop the drive in the forward direction. Setting bit 1 will start and stop the drive in reverse.

**Setting 1: Run/Stop, FWD/REV**

Setting bit 0 of MEMOBUS/Modbus register will start and stop the drive. Setting bit 1 changes the direction.

# B.5 Drive Operations by MEMOBUS/Modbus

The drive operations that can be performed by MEMOBUS/Modbus communication depend on drive parameter settings. This section explains the functions that can be used and related parameter settings.

### ◆ Observing the Drive Operation

A PLC can perform the following actions with MEMOBUS/Modbus communications at any time regardless of parameter settings (except for H5-□□parameters):

- observe drive status and drive control terminal status from a PLC.
- read and write parameters.
- set and reset faults.
- set multi-function inputs.

**Note:** Input settings from the input terminals S□ and from MEMOBUS/Modbus communications are both linked by a logical OR operation.

### ◆ Controlling the Drive

Select an external reference and adjust the parameters in [Table B.1](#) accordingly to start and stop the drive or set the frequency reference using MEMOBUS/Modbus communications.

**Table B.1 Setting Parameters for Drive Control from MEMOBUS/Modbus**

Reference Source	Parameter	Name	Required Setting
External Reference 1	b1-01	Frequency Reference Selection 1	2
	b1-02	Run Command Selection 1	2
External Reference 2	b1-15	Frequency Reference Selection 2	2
	b1-16	Run Command Selection 2	2

*Refer to b1-01: Frequency Reference Selection 1 on page 18 and Refer to b1-02: Run Command Selection 1 on page 19 for details on external reference parameter selections. Refer to Setting 2: External Reference 1/2 Selection on page 96 for instructions on selecting external references 1 and 2.*

## B.6 Communications Timing

To prevent overrun in the slave drive, the master should wait a certain time between sending messages to the same drive. In the same way, the slave drive must wait before sending response messages to prevent an overrun in the master. This section explains the message timing.

### ◆ Command Messages from Master to Drive

The master must wait for a specified time between receiving a response and resending the same type of command to the same slave drive to prevent overrun and data loss. The minimum wait time depends on the command as shown in the table below.

Table B.2 Minimum Wait Time for Sending Messages

Command Type	Example	Minimum Wait Time
1	<ul style="list-style-type: none"> <li>Control command (Run, Stop)</li> <li>Set inputs/outputs</li> <li>Read monitors and parameter values</li> </ul>	5 ms
2	<ul style="list-style-type: none"> <li>Write parameters</li> </ul>	50 ms
3	<ul style="list-style-type: none"> <li>Save changes using an Enter command</li> </ul>	3 to 5 s <i>&lt;/i&gt;</i>

<1> If the drive receives command type 1 data during the minimum wait time, it will perform the command and then respond. However, if it receives a command type 2 or 3 during that time, either a communication error will result or the command will be ignored.

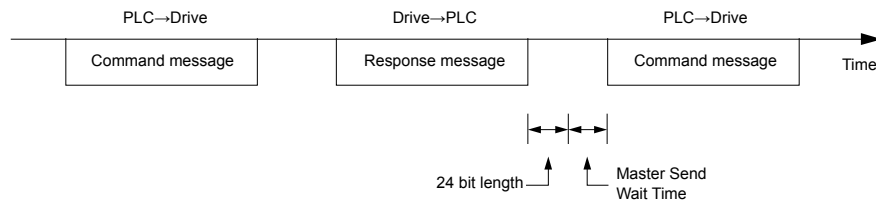

Figure B.7 Minimum Wait Time for Sending Messages

### ◆ Response Messages from Drive to Master

If the drive receives a command from the master, it will process the data received and wait for the time set in H5-06 until it responds. Increase H5-06 if the drive response causes overrun in the master.

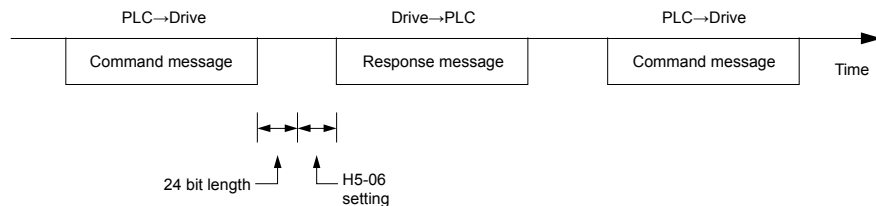

Figure B.8 Minimum Response Wait Time

## B.7 Message Format

### ◆ Message Content

In MEMOBUS/Modbus communications, the master sends commands to the slave, and the slave responds. The message format is configured for both sending and receiving as shown below, and the length of data packets depends on the command (function) content.

SLAVE ADDRESS
FUNCTION CODE
DATA
ERROR CHECK

### ◆ Slave Address

The slave address in the message defines the note the message is sent to. Use addresses between 0 and FF (hex). If a message with slave address 0 is sent (broadcast), the command from the master will be received by all slaves. The slaves do not provide a response to a broadcast type message.

### ◆ Function Code

The three types of function codes are shown in the table below.

Function Code	Function Name	Data Length (bytes)			
		Command Message		Response Message	
		Minimum	Maximum	Minimum	Maximum
03H	Read MEMOBUS/Modbus registers	8	8	7	37
08H	Loopback test	8	8	8	8
10H	Write to multiple MEMOBUS/Modbus registers	11	41	8	8

### ◆ Data

Configure consecutive data by combining the MEMOBUS/Modbus register address (test code in case of a loopback test) and the data the register contains. The data length changes depending on the command details.

A drive MEMOBUS/Modbus register always has a data length of two bytes. Data written into drive registers must also always have a length of two bytes. Register data read out from the drive will always consist of two bytes.

### ◆ Error Check

The drive uses a CRC-16 (cyclic redundancy check, checksum method) for checking data validity. Use the procedure described below when calculating the CRC-16 checksum for command data or when verifying response data.

#### ■ Command Data

When the drive receives data, it calculates the CRC-16 checksum from the data and compares it to the CRC-16 value received within the message. Both must match before a command is processed.

An initial value of FFFFH (i.e., all 16 bits equal 1) must be used for CRC-16 calculations in the MEMOBUS/Modbus protocol.

Calculate the CRC-16 checksum using the following steps:

1. The starting value is FFFFH.
2. Perform an XOR operation of this value and the slave address.
3. Right shift the result.
4. When the overflow bit of the shift operation becomes 1, perform an XOR operation of the result from step 3 above and the fix value A001H.
5. Repeat steps 3 and 4 until eight shift operations have been performed.
6. After eight shift operations, perform an XOR operation with the result and the next data in the message (function code, register address, data). Continue with steps 3 to 5 until the last data has been processed.
7. The result of the last shift or XOR operation is the checksum.

The example in *Table B.3* shows the CRC-16 calculation of the slave address 02H and the function code 03H, yielding the result 40D1H.

**Note:** This example does not show the calculation for a complete MEMOBUS/Modbus command. Normally data would follow in the calculation.

**Table B.3 CRC-16 Checksum Calculation Example**

Description	Calculation	Overflow	Description	Calculation	Overflow
Initial Value (FFFFH)	1111 1111 1111 1111		Function Code 03H	0000 0000 0000 0011	
Address 02H	0000 0000 0000 0010		XOR w result	1000 0001 0011 1101	
XOR w initial value	1111 1111 1111 1101		Shift 1	0100 0000 1001 1110	1
Shift 1	0111 1111 1111 1110	1	XOR w A001H	1010 0000 0000 0001	
XOR w A001H	1010 0000 0000 0001		XOR result	1110 0000 1001 1111	
XOR result	1101 1111 1111 1111		Shift 2	0111 0000 0100 1111	1
Shift 2	0110 1111 1111 1111	1	XOR w A001H	1010 0000 0000 0001	
XOR w A001H	1010 0000 0000 0001		XOR result	1101 0000 0100 1110	
XOR result	1100 1111 1111 1110		Shift 3	0110 1000 0010 0111	0
Shift 3	0110 0111 1111 1111	0	Shift 4	0011 0100 0001 0011	1
Shift 4	0011 0011 1111 1111	1	XOR w A001H	1010 0000 0000 0001	
XOR w A001H	1010 0000 0000 0001		XOR result	1001 0100 0001 0010	
XOR result	1001 0011 1111 1110		Shift 5	0100 1010 0000 1001	0
Shift 5	0100 1001 1111 1111	0	Shift 6	0010 0101 0000 0100	1
Shift 6	0010 0100 1111 1111	1	XOR w A001H	1010 0000 0000 0001	
XOR w A001H	1010 0000 0000 0001		XOR result	1000 0101 0000 0101	
XOR result	1000 0100 1111 1110		Shift 7	0100 0010 1000 0010	1
Shift 7	0100 0010 0111 1111	0	XOR w A001H	1010 0000 0000 0001	
Shift 8	0010 0001 0011 1111	1	XOR result	1110 0010 1000 0011	
XOR w A001H	1010 0000 0000 0001		Shift 8	0111 0001 0100 0001	1
XOR result	1000 0001 0011 1110		XOR w A001H	1010 0000 0000 0001	
Perform operations with next data (function code)			XOR result	1101 0001 0100 0000	
			CRC-16	1101 0001 0100 0000	
				D140H	
Continue from here with next data.					

**Response Data**

Perform a CRC-16 calculation on the response message data as described above as a validation check. The result should match the CRC-16 checksum received within the response message.

## B.8 Message Examples

Below are some examples of command and response messages.

### ◆ Reading Drive MEMOBUS/Modbus Register Contents

Using the function code 03H (Read), a maximum of 16 MEMOBUS/Modbus registers can be read out at a time.

The following table shows message examples when reading status signals, error details, data link status, and frequency references from the slave 2 drive.

Command Message			Response Message (normal)			Response Message (fault)		
Slave Address		02H	Slave Address		02H	Slave Address		02H
Function Code		03H	Function Code		03H	Function Code		83H
Starting No.	Upper	00H	Data Quantity		08H	Error Code		03H
	Lower	20H	1st storage register	Upper	00H	CRC-16	Upper	F1H
Data Quantity	Upper	00H		Lower	65H		Lower	31H
	CRC-16	Upper	45H	Next storage register	Upper	00H		
Lower		04H	Lower		00H			
CRC-16	Upper	45H	Next storage register	Upper	00H			
	Lower	F0H		Lower	00H			
CRC-16	Upper	45H	Next storage register	Upper	01H			
	Lower	F0H		Lower	F4H			
CRC-16	Upper	45H	CRC-16	Upper	AFH			
	Lower	F0H		Lower	82H			

### ◆ Loopback Test

Function code 08H performs a loopback test that returns a response message with exactly the same content as the command message. The response message can be used to check communications between the master and slave. User-defined test code and data values can also be set.

The following table shows a message example when performing a loopback test with the slave 1 drive.

Command Message			Response Message (normal)			Response Message (fault)		
Slave Address		01H	Slave Address		01H	Slave Address		01H
Function Code		08H	Function Code		08H	Function Code		89H
Test Code	Upper	00H	Test Code	Upper	00H	Error Code		01H
	Lower	00H		Lower	00H	CRC-16	Upper	86H
Data	Upper	A5H	Data	Upper	A5H		Lower	50H
	Lower	37H		Lower	37H			
CRC-16	Upper	DAH	CRC-16	Upper	DAH			
	Lower	8DH		Lower	8DH			

### ◆ Writing to Multiple Registers

Function code 10H allows the user to write multiple drive MEMOBUS/Modbus registers with one message. This process works similar to reading registers, in that the address of the first register to be written and the data quantity are set in the command message. The data to be written must be consecutive so that the register addresses are in order, starting from the specified address in the command message. The data order must be high byte then lower byte.

The following table shows an example of a message where a forward operation has been set with a frequency reference of 60.0 Hz for the slave 1 drive.

If parameter values are changed using the Write command, an Enter command may be necessary to activate or save the data depending on the setting of H5-11. [Refer to H5-11: Communications Enter Function Selection on page 123](#) and [Refer to Enter Command on page 344](#) for detailed descriptions.

Command Message			Response Message (normal)			Response Message (fault)		
Slave Address		01H	Slave Address		01H	Slave Address		01H
Function Code		10H	Function Code		10H	Function Code		90H
Starting No.	Upper	00H	Starting No.	Upper	00H	Error Code		02H
	Lower	01H		Lower	01H	CRC-16	Upper	CDH
Data Quantity	Upper	00H	Data Quantity	Upper	00H		Lower	C1H
	Lower	02H		Lower	02H			
Number of Bytes		04H	CRC-16	Upper	10H			
Starting Data	Upper	00H		Lower	08H			
	Lower	01H						
Next Data	Upper	02H						
	Lower	58H						
CRC-16	Upper	63H						
	Lower	39H						

**Note:** Double the number of the data quantity for the number of bytes in the command message.

## B.9 MEMOBUS/Modbus Data Table

The table below lists all MEMOBUS/Modbus data. There are three types of data: command data, monitor data, and broadcast data.

### ◆ Command Data

It is possible to both read and write command data.

**Note:** Bits that are not used should be set to 0. Refrain from writing to reserved registers.

Register No.	Contents	
0000H	Reserved	
0001H	Operation Commands and Multi-function Inputs	
	bit 0	H5-12 = 0: Forward Run Command (0 = Stop, 1 = Forward Run) H5-12 = 1: Run Command (0 = Stop, 1 = Run)
	bit 1	H5-12 = 0: Reverse Run Command (0 = Stop, 1 = Reverse Run) H5-12 = 1: Forward/Reverse (0 = Forward, 1 = Reverse)
	bit 2	External Fault (EF0)
	bit 3	Fault Reset
	bit 4	Multi-Function Input 1 Function is ComRef when H1-01 = 40 (Forward/Stop). <i>Refer to d: Reference Settings on page 59</i> for ComRef explanations.
	bit 5	Multi-Function Input 2 Function is ComCtrl when H1-02 = 41 (Reverse/Stop). <i>Refer to d: Reference Settings on page 59</i> for ComCtrl explanations.
	bit 6	Multi-Function Input 3
	bit 7	Multi-Function Input 4
	bit 8	Multi-Function Input 5
	bit 9	Multi-Function Input 6
	bit A	Multi-Function Input 7
	bit B	Multi-Function Input 8
	bit C to F	Reserved
0002H	Frequency Reference	Units are determined by parameter o1-03.
0003H	V/f Gain	
0004H	Torque Reference/Torque Limit, 0.1% units, signed (Usable only if Torque Control is enabled)	
0005H	Torque Compensation, 0.1% units, signed (Usable only if Torque Control is enabled)	
0006H	PID Target, 0.01% units, signed	
0007H	Analog Output Terminal FM Setting (10 V / 4000 H)	
0008H	Analog Output Terminal AM Setting (10 V / 4000 H)	
0009H	Settings for Multi-Function Digital Outputs	
	bit 0	Multi-Function Contact Output 1 (terminal M1-M2)
	bit 1	Multi-Function Contact Output 2 (terminal M3-M4)
	bit 2	Multi-Function Contact Output 3 (terminal M5-M6)
	bit 3 to 5	Reserved
	bit 6	Enables the function in bit 7
	bit 7	Fault Contact Output (terminal MA/MB-MC)
bit 8 to F	Reserved	
000AH	Pulse Output Terminal MP Setting, 1 Hz units, Setting Range: 0 to 32000	
000BH to 000EH	Reserved	



Register No.	Contents	
000FH	Control Selection Setting	
	bit 0	Reserved
	bit 1	PID Setpoint Input
	bit 2	Torque reference / torque limit input (enables the setting from MEMOBUS/Modbus)
	bit 3	Torque compensation input (enables the setting from MEMOBUS/Modbus)
	bit 4 to B	Reserved
	bit C	Enable Terminal S5 Input for Broadcast Data
	bit D	Enable Terminal S6 Input for Broadcast Data
	bit E	Enable Terminal S7 Input for Broadcast Data
bit F	Enable Terminal S8 Input for Broadcast Data	
0010H to 001AH	Reserved	
001BH	Analog Monitor Option AO-A3 Analog Output 1 (10 V/4000 H)	
001CH	Analog Monitor Option AO-A3 Analog Output 2 (10 V/4000 H)	
001DH	Digital Output Option DO-A3 Output (Binary)	
001EH to 001FH	Reserved	

◆ Monitor Data

Monitor data can be read only.

Register No.	Contents	
0020H	Drive Status 1	
	bit 0	During Run
	bit 1	During Reverse
	bit 2	Drive Ready
	bit 3	Fault
	bit 4	Data Setting Error
	bit 5	Multi-Function Contact Output (terminal M1-M2)
	bit 6	Multi-function Photocoupler output 1 □ Terminal P1 - PC □
	bit 7	Multi-function Photocoupler output 2 □ Terminal P2 - PC □
	bit 8 to bit D	Reserved
	bit E	ComRef status
bit F	ComCtrl status	
0021H	Fault Contents 1	
	bit 0	Overcurrent (oC), Ground fault (GF)
	bit 1	Overvoltage (ov)
	bit 2	Drive Overload (oL2)
	bit 3	Overheat 1 (oH1), Drive Overheat Warning (oH2)
	bit 4	Dynamic Braking Transistor Fault (rr), Braking Resistor Overheat (rH)
	bit 5	Reserved
	bit 6	PID Feedback Loss (FbL / FbH)
	bit 7	EF to EF8: External Fault
	bit 8	CPF□□: Hardware Fault (includes oFx)
	bit 9	Motor Overload (oL1), Overtorque Detection 1/2 (oL3/oL4), Undertorque Detection 1/2 (UL3/UL4)
	bit A	PG Disconnected (PGo), PG Hardware Fault (PGoH), Overspeed (oS), Excessive Speed Deviation (dEv)
	bit B	Main Circuit Undervoltage (Uv)
	bit C	Undervoltage (Uv1), Control Power Supply Undervoltage (Uv2), Soft Charge Circuit Fault (Uv3)
bit D	Output Phase Loss (LF), Input Phase Loss (PF)	
bit E	MEMOBUS/Modbus Communication Error (CE), Option Communication Error (bUS)	
bit F	Operator Connection Fault (oPr)	

## B.9 MEMOBUS/Modbus Data Table

Register No.	Contents	
0022H	Data Link Status	
	bit 0	Writing data or switching motors
	bit 1	Reserved
	bit 2	
	bit 3	Upper or lower limit error
	bit 4	Data conformity error
	bit 5	Writing to EEPROM
	bit 6 to bit F	Reserved
0023H	U1-01 Frequency Reference </>	
0024H	U1-02 Output Frequency </>	
0025H	U1-06 Output Voltage Reference, 0.1 V units (units are determined by parameter H5-10)	
0026H	U1-03 Output Current, 0.1 A units	
0027H	U1-08 Output Power	
0028H	U1-09 Torque Reference	
0029H	Fault Contents 2	
	bit 0	IGBT Short Circuit (SC)
	bit 1	Ground Fault (GF)
	bit 2	Input Phase Loss (PF)
	bit 3	Output Phase Loss (LF)
	bit 4	Braking Resistor Overheat (rH)
	bit 5	Reserved
	bit 6	Motor Overheat 2 (PTC input) (oH4)
bit 7 to bit F	Reserved	
002AH	Alarm Contents 1	
	bit 0, 1	Reserved
	bit 2	Run Command Input Error (EF)
	bit 3	Drive Baseblock (bb)
	bit 4	Overtorque Detection 1 (oL3)
	bit 5	Heatsink Overheat (oH)
	bit 6	Overvoltage (ov)
	bit 7	Undervoltage (Uv)
	bit 8	Cooling Fan Error (FAn)
	bit 9	MEMOBUS/Modbus Communication Error (CE)
	bit A	Option Communication Error (bUS)
	bit B	Undertorque Detection 1/2 (UL3/UL4)
	bit C	Motor Overheat (oH3)
	bit D	PID Feedback Loss (FbL, FbH)
	bit E	Reserved
bit F	Serial Communication Transmission Error (CALL)	
002BH	U1-10 Input Terminal Status	
	bit 0	Terminal S1 Closed
	bit 1	Terminal S2 Closed
	bit 2	Terminal S3 Closed
	bit 3	Terminal S4 Closed
	bit 4	Terminal S5 Closed
	bit 5	Terminal S6 Closed
	bit 6	Terminal S7 Closed
	bit 7	Terminal S8 Closed
bit 8 to bit F	Reserved	

Register No.	Contents	
002CH	Drive Status 2	
	bit 0	During Run
	bit 1	Zero Speed
	bit 2	Speed Agree
	bit 3	User Speed Agree
	bit 4	Frequency Detection 1
	bit 5	Frequency Detection 2
	bit 6	Drive Ready
	bit 7	During Undervoltage
	bit 8	During Baseblock
	bit 9	Frequency Reference from Operator Keypad
	bit A	Run Command from Operator Keypad
	bit B	Over/Undertorque 1, 2
	bit C	Frequency Reference Loss
	bit D	During Fault Restart
	bit E	Fault
bit F	Communication Timeout	
002DH	U1-11 Output Terminal Status	
	bit 0	Multi-Function Contact Output 1 (terminal M1-M2)
	bit 1	Multi-Function PHC output 1 (P1-PC)
	bit 2	Multi-Function PHC output 2 (P2-PC)
	bit 3 to 6	Reserved
	bit 7	Fault Contact Output (terminal MA/MB-MC)
	bit 8 to F	Reserved
002EH	Reserved	
002FH	Frequency Reference Bias (from Up/Down 2 Function), 0.1% units	
0030H	Reserved	
0031H	DC Bus Voltage, 1 Vdc units	
0032H	Torque Reference (U1-09), 1% units	
0033H	Reserved	
0034H	Product Code 1 [ASCII], Product Type (A0 for A1000)	
0035H	Product Code 2 [ASCII], Region Code	
0036H, 0037H	Reserved	
0038H	PID Feedback, 0.1% units, unsigned, 100% / max. output frequency	
0039H	PID Input, 0.1% units, signed, 100% / max. output frequency	
003AH	PID Output, 0.1% units, signed, 100% / max. output frequency	
003BH, 003CH	Reserved	
003DH	Communications Error Contents <>	
	bit 0	CRC Error
	bit 1	Data Length Error
	bit 2	Reserved
	bit 3	Parity Error
	bit 4	Overflow Error
	bit 5	Framing Error
	bit 6	Timeout
bit 7 to bit F	Reserved	
003EH	Output Frequency	r/min <4>
003FH		0.01% units
0040H to 004AH	Used for various monitors U1-□□. Refer to U: Monitors on page 296 for parameter details.	

## B.9 MEMOBUS/Modbus Data Table

Register No.	Contents	
004BH	Drive status (U1-12)	
	bit 0	During Run
	bit 1	During Zero Speed
	bit 2	During Reverse Run
	bit 3	During Fault Reset Signal Input
	bit 4	During Speed Agree
	bit 5	Drive Ready
	bit 6	Alarm
	bit 7	Fault
	bit 8	During Operation Error (oPE□□)
	bit 9	During Momentary Power Loss
	bit A	Motor 2 selected
	bit B	Reserved
	bit E	ComRef status, NetRef status
bit F	ComCtrl status, NetCtrl status	
004CH to 007EH	Used for various monitors U1-□□, U4-□□, U5-□□ and U6-□□. <i>Refer to U: Monitors on page 296</i> for parameter details.	
007FH	Alarm Code, <i>Refer to Alarm Register Contents on page 343</i> for alarm codes.	
0080H to 0097H	Used for monitors U2-□□, U3-□□. <i>Refer to U: Monitors on page 296</i> for parameter details and <i>Refer to Fault Trace Contents on page 341</i> for register value descriptions.	
0098H	High Word of Accumulated Operation Time Monitor, 10 h units (U4-01)	
0099H	Low Word of Accumulated Operation Time Monitor, 1 h units (U4-01)	
009AH	High Word of Cooling Fan Operation Time Monitor (U4-03)	
009BH	Low Word of Cooling Fan Operation Time Monitor (U4-03)	
009CH to 00AAH	Reserved	
00ABH	Drive Rated Current <4>	
00ACH	Motor Speed (U1-05)	r/min units <4>
00ADH		0.01% units
00AEH, 00AFH	Reserved	
00B0H	Option Code Connected to CN5-A	Register contains ASCII code of the option card. DI-A3 = 0x01 DO-A3 = 0x02 AI-A3 = 0x03 AO-A3 = 0x04 PG-B3 = 0x11 PG-X3 = 0x12 Communication Option: Register contains ASCII code of 1st and 3rd digit of the option card type number. Example: Register value is 5343H for “SC” if a SI-C3 option card is installed.
00B1H	Reserved	
00B2H	Option Code Connected to CN5-B	
00B3H	Option Code Connected to CN5-C	
00B4H	Reserved	
00B5H	Frequency Reference After Soft-starter (U1-16)	r/min units <4>
00B6H		0.01% units
00B7H	Frequency Reference	r/min <4>
00B8H		0.01% units
00B9H to 00BEH	Reserved	
00BFH	Lists the last two digits of operation error code oPE□□.	

Register No.	Contents	
00C0H	Fault Contents 3	
	bit 0	Blown fuse (PUF)
	bit 1	Undervoltage (Uv1)
	bit 2	Control Power Supply Undervoltage (Uv2)
	bit 3	Soft Charge Circuit Fault (Uv3)
	bit 4	IGBT Short Circuit (SC)
	bit 5	Ground Fault (GF)
	bit 6	Overcurrent (oC)
	bit 7	Overvoltage (ov)
	bit 8	Heatsink Overheat (oH)
	bit 9	Heatsink Overheat (oH1)
	bit A	Motor Overload (oL1)
	bit B	Drive Overload (oL2)
	bit C	Overtorque Detection 1 (oL3)
	bit D	Overtorque Detection 2 (oL4)
	bit E	Reserved
bit F	Reserved	
00C1H	Fault Contents 4	
	bit 0	External Fault at input terminal S3 (EF3)
	bit 1	External Fault at input terminal S4 (EF4)
	bit 2	External Fault at input terminal S5 (EF5)
	bit 3	External Fault at input terminal S6 (EF6)
	bit 4	External Fault at input terminal S7 (EF7)
	bit 5	External Fault at input terminal S8 (EF8)
	bit 6	Cooling Fan Error (FAn)
	bit 7	Overspeed (os)
	bit 8	Excessive Speed Deviation (dEv)
	bit 9	PG Disconnected (PGo)
	bit A	Input Phase Loss (PF)
	bit B	Output Phase Loss (LF)
	bit C	Motor Overheat (PTC input) (oH3)
	bit D	Digital Operator Connection Fault (oPr)
	bit E	EEPROM Write Error (Err)
bit F	Motor Overheat Fault (PTC input) (oH4)	
00C2H	Fault Contents 5	
	bit 0	MEMOBUS/Modbus Communication Error (CE)
	bit 1	Option Communication Error (bUS)
	bit 2, 3	Reserved
	bit 4	Control Fault (CF)
	bit 5	Zero Servo Fault (SvE)
	bit 6	Option External Fault (EF0)
	bit 7	PID Feedback Loss (FbL)
	bit 8	Undertorque Detection 1 (UL3)
	bit 9	Undertorque Detection 2 (UL4)
	bit A	High Slip Braking Overload (oL7)
	bit B to E	Reserved
bit F	Hardware Fault (includes oFx)	

## B.9 MEMOBUS/Modbus Data Table

Register No.	Contents	
00C3H	Fault Contents 6	
	bit 0	Reserved
	bit 1	Reserved
	bit 2	Reserved
	bit 3	Reserved
	bit 4	Reserved
	bit 5	Reserved
	bit 6	Reserved
	bit 7	PG Hardware Fault (PGoH)
	bit 8	SI-T3 Watchdog Error (E5)
	bit 9	Reserved
	bit A	Too many speed search restarts (SEr)
	bit B to F	Reserved
00C4H	Fault Contents 7	
	bit 0	PID Feedback Loss (FbH)
	bit 1	External Fault 1, input terminal S1 (EF1)
	bit 2	External Fault 2, input terminal S2 (EF2)
	bit 3	Mechanical Weakening Detection 1 (oL5)
	bit 4	Mechanical Weakening Detection 2 (UL5)
	bit 5	Current Offset Fault (CoF)
	bit 6, 7	Reserved
	bit 8	DriveWorksEZ Fault (dWFL)
	bit 9 to B	Reserved
	bit C	Output Voltage Detection Fault (voF)
	bit D	Reserved
	bit E	Reserved
	bit F	Reserved
00C5H	Fault Contents 8	
	bit 0	Reserved
	bit 1	Reserved
	bit 2	Thermistor Disconnect (THo)
	bit 3 to 9	Reserved
	bit A	Polarity Judge Timeout (dv7)
	bit B to D	Reserved
	bit E	Power Unit Output Phase Loss 3 (LF3)
	bit F	Current Unbalance (UnbC)
00C6H	Fault Contents 9	
	bit 0	Gate Drive Board Undervoltage (Uv4)
	bit 1	Uv5 <input type="checkbox"/> MC/FAN Abnormal low-voltage power supply <input type="checkbox"/>
	bit 2	oH6 <input type="checkbox"/> Thermal converter <input type="checkbox"/>
	bit 3	dFAn <input type="checkbox"/> FAN abnormal diode module <input type="checkbox"/>
	bit 4	EFAn <input type="checkbox"/> FAN panel anomalies <input type="checkbox"/>
	bit 5 to F	Reserved
00C7H	Reserved	

Register No.	Contents	
00C8H	Alarm Contents 2	
	bit 0	Undervoltage (Uv)
	bit 1	Overvoltage (ov)
	bit 2	Heatsink Overheat (oH)
	bit 3	Drive Overheat (oH2)
	bit 4	Overtorque 1 (oL3)
	bit 5	Overtorque 2 (oL4)
	bit 6	Run Commands Input Error (EF)
	bit 7	Drive Baseblock (bb)
	bit 8	External Fault 3, input terminal S3 (EF3)
	bit 9	External Fault 4, input terminal S4 (EF4)
	bit A	External Fault 5, input terminal S5 (EF5)
	bit B	External Fault 6, input terminal S6 (EF6)
	bit C	External Fault 7, input terminal S7 (EF7)
	bit D	External Fault 8, input terminal S8 (EF8)
	bit E	Cooling Fan Error (FAn)
bit F	Overspeed (oS)	
00C9H	Alarm Contents 3	
	bit 0	Excessive Speed Deviation (dEv)
	bit 1	PG Disconnected (PGo)
	bit 2	Digital Operator Connection Fault (oPr)
	bit 3	MEMOBUS/Modbus Communication Error (CE)
	bit 4	Option Communication Error (bUS)
	bit 5	Serial Communication Transmission Error (CALL)
	bit 6	Motor Overload (oL1)
	bit 7	Drive Overload (oL2)
	bit 8	Reserved
	bit 9	Option Card External fault (EF0)
	bit A	Motor 2 Switch command input during run (rUn)
	bit B	Reserved
	bit C	Serial Communication Transmission Error (CALL)
	bit D	Undertorque Detection 1 (UL3)
	bit E	Undertorque Detection 2 (UL4)
bit F	MEMOBUS/Modbus Test Mode Fault (SE)	
00CAH	Alarm Contents 4	
	bit 0	Reserved
	bit 1	Motor Overheat 1 (PTC Input) (oH3)
	bit 2 to 5	Reserved
	bit 6	PID Feedback Loss (FbL)
	bit 7	PID Feedback Loss (FbH)
	bit 8	Reserved
	bit 9	Drive Disabled (dnE)
	bit A	PG Disconnected (PGo)
bit B to F	Reserved	

## B.9 MEMOBUS/Modbus Data Table

Register No.	Contents	
00CBH	Alarm Contents 5	
	bit 0	SI-T3 Watchdog Error (E5)
	bit 1	SI-T3 Station Address Setting Error (AEr)
	bit 2	SI-T3 Comm. Cycle Setting Error (CyC)
	bit 3	High Current Alarm (HCA)
	bit 4	Cooling Fan Maintenance Time (LT-1)
	bit 5	Soft Charge Bypass Relay Maintenance Time (LT-2)
	bit 6	Reserved
	bit 7	SI-S EEPROM Error (EEP)
	bit 8	External Fault 1 (input terminal S1) (EF1)
	bit 9	External Fault 2 (input terminal S2) (EF2)
	bit A	Safe Disable Input (HbbF) <S>
	bit B	Safe Disable Input (Hbb) <S>
	bit C	Mechanical Weakening Detection 1 (oL5)
	bit D	Mechanical Weakening Detection 2 (UL5)
bit E, F	Reserved	
00CCH	Alarm Contents 6	
	bit 0	Output Voltage Detection Fault (VoF)
	bit 1	IGBT Maintenance Time (90%) (TrPC)
	bit 2	Capacitor Maintenance Time (LT-3)
	bit 3	IGBT Maintenance Time (50%) (LT-4)
	bit 4	Unused
	bit 5 to 7	Reserved
	bit 8	DriveWorksEZ Alarm (dWAL)
	bit 9 to F	Reserved
00CDH	bit 0 to 7	Reserved
	bit 8	EFAn (Abnormal Fan Alarm)
	bit 9	Reserved
	bit A	dFAn (Abnormal Fan Diode Module)
	bit B to F	Reserved
00CEH-00CFH	Reserved	
00D0H	CPF Contents 1	
	bit 0, 1	Reserved
	bit 2	A/D Conversion Error (CPF02)
	bit 3	PWM Data Fault (CPF03)
	bit 4, 5	Reserved
	bit 6	EEPROM Memory Data Error (CPF06)
	bit 7	Terminal Board Connection Error (CPF07)
	bit 8	EEPROM Serial Communications Fault (CPF08)
	bit 9, A	Reserved
	bit B	RAM Fault (CPF11)
	bit C	FLASH Memory Fault (CPF12)
	bit D	Watchdog Circuit Exception (CPF13)
	bit E	Control Circuit Fault (CPF14)
bit F	Reserved	



Register No.	Contents	
00D1H	CPF Contents 2	
	bit 0	Clock Fault (CPF16)
	bit 1	Timing Fault (CPF17)
	bit 2	Control Circuit Fault (CPF18)
	bit 3	Control Circuit Fault (CPF19)
	bit 4	Hardware fault at power up (CPF20)
	bit 5	Hardware fault at communication start up (CPF21)
	bit 6	A/D Conversion Fault (CPF22)
	bit 7	PWM Feedback Fault (CPF23)
	bit 8	Drive Unit Signal Fault (CPF24)
	bit 9	Terminal board is not properly connected. (CPF25)
	bit A	ASIC BB Circuit Error (CPF26)
	bit B	ASIC PWM Setting Register Error (CPF27)
	bit C	ASIC PWM Pattern Error (CPF28)
	bit D	ASIC On-delay Error (CPF29)
	bit E	ASIC BBON Error (CPF30)
bit F	ASIC Code Error (CPF31)	
00D2H	bit 0	ASIC Start-up Error (CPF32)
	bit 1	Watch-dog Error (CPF33)
	bit 2	ASIC Power/Clock Error (CPF34)
	bit 3	External A/D Converter Error (CPF35)
	bit 4 to 8	Reserved
	bit 9	Control Circuit Error (CPF41)
	bit A	Control Circuit Error (CPF42)
	bit B	Control Circuit Error (CPF43)
	bit C	Control Circuit Error (CPF44)
	bit D	Control Circuit Error (CPF45)
bit E, F	Reserved	
00D3H to 00D7H	Reserved	
00D8H	oFA0x Contents (CN5-A)	
	bit 0	Option Compatibility Error (oFA00)
	bit 1	Option not properly connected (oFA01)
	bit 2	Same type of option card already connected (oFA02)
	bit 3, 4	Reserved
	bit 5	A/D Conversion Error (oFA05)
	bit 6	Option Response Error (oFA06)
	bit 7 to F	Reserved
00D9H	oFA1x Contents (CN5-A)	
	bit 0	Option RAM Fault (oFA10)
	bit 1	Option Operation Mode Fault (SLMOD) (oFA11)
	bit 2	Drive Receive CRC Error (oFA12)
	bit 3	Drive Receive Frame Error (oFA13)
	bit 4	Drive Receive Abort Error (oFA14)
	bit 5	Option Receive CRC Error (oFA15)
	bit 6	Option Receive Frame Error (oFA16)
	bit 7	Option Receive Abort Error (oFA17)
bit 8 to F	Reserved	
00DAH to 00DBH	Reserved	

## B.9 MEMOBUS/Modbus Data Table

Register No.	Contents	
00DBH	oFA3x Contents (CN5-A)	
	bit 0	Comm. ID Error (oFA30)
	bit 1	Model Code Error (oFA31)
	bit 2	Sumcheck Error (oFA32)
	bit 3	Comm. option timeout waiting for response (oFA33)
	bit 4	MEMOBUS Timeout (oFA34)
	bit 5	Drive timeout waiting for response (oFA35)
	bit 6	CI Check Error (oFA36)
	bit 7	Drive timeout waiting for response (oFA37)
	bit 8	Control Command Selection Error (oFA38)
	bit 9	Drive timeout waiting for response (oFA39)
	bit A	Control Response Selection 1 Error (oFA40)
	bit B	Drive timeout waiting for response (oFA41)
	bit C	Control Response Selection 2 Error (oFA42)
	bit D	Control Response Selection Error (oFA43)
bit E, F	Reserved	
00DCH	oFb0x Contents (CN5-B)	
	bit 0	Option compatibility error (oFb00)
	bit 1	Option not properly connected (oFb01)
	bit 2	Same type of option card already connected (oFb02)
	bit 3, 4	Reserved
	bit 5	A/D Conversion Fault (oFb05)
	bit 6	Option Response Error (oFb06)
	bit 7 to F	Reserved
00DDH	oFb1x Contents (CN5-B)	
	bit 0	Option RAM Fault (oFb10)
	bit 1	Option Operation Mode Fault (SLMOD) (oFb11)
	bit 2	Drive Receive CRC Error (oFb12)
	bit 3	Drive Receive Frame Error (oFb13)
	bit 4	Drive Receive Abort Error (oFb14)
	bit 5	Option Receive CRC Error (oFb15)
	bit 6	Option Receive Frame Error (oFb16)
	bit 7	Option Receive Abort Error (oFb17)
bit 8 to F	Reserved	
00DEH to 00DFH	Reserved	

Register No.	Contents	
00E0H	oFb3x Contents (CN5-B)	
	bit 0	Comm. ID Error (oFb30)
	bit 1	Model Code Error (oFb31)
	bit 2	Sumcheck Error (oFb32)
	bit 3	Comm. option timeout waiting for response (oFb33)
	bit 4	MEMOBUS Timeout (oFb34)
	bit 5	Drive timeout waiting for response (oFb35)
	bit 6	CI Check Error (oFb36)
	bit 7	Drive timeout waiting for response (oFb37)
	bit 8	Control Command Selection Error (oFb38)
	bit 9	Drive timeout waiting for response (oFb39)
	bit A	Control Response Selection 1 Error (oFb40)
	bit B	Drive timeout waiting for response (oFb41)
	bit C	Control Response Selection 2 Error (oFb42)
	bit D	Control Response Selection Error (oFb43)
bit E, F	Reserved	
00E1H	oFC0x Contents (CN5-C)	
	bit 0	Option compatibility error (oFC00)
	bit 1	Option not properly connected (oFC01)
	bit 2	Same type of option card already connected (oFC02)
	bit 3, 4	Reserved
	bit 5	A/D Conversion Fault (oFC05)
	bit 6	Option Response Error (oFC06)
bit 7 to F	Reserved	
00E2H	oFC1x Contents (CN5-C)	
	bit 0	Option RAM Fault (oFC10)
	bit 1	Option Operation Mode Fault (SLMOD) (oFC11)
	bit 2	Drive Receive CRC Error (oFC12)
	bit 3	Drive Receive Frame Error (oFC13)
	bit 4	Drive Receive Abort Error (oFC14)
	bit 5	Option Receive CRC Error (oFC15)
	bit 6	Option Receive Frame Error (oFC16)
	bit 7	Option Receive Abort Error (oFC17)
bit 8 to F	Reserved	
00E3H, 00E4H	Reserved	

## B.9 MEMOBUS/Modbus Data Table

Register No.	Contents	
00E5H	oFC3x Contents (CN5-C)	
	bit 0	Comm. ID Error (oFC30)
	bit 1	Model Code Error (oFC31)
	bit 2	Sumcheck Error (oFC32)
	bit 3	Comm. option timeout waiting for response (oFC33)
	bit 4	MEMOBUS Timeout (oFC34)
	bit 5	Drive timeout waiting for response (oFC35)
	bit 6	CI Check Error (oFC36)
	bit 7	Drive timeout waiting for response (oFC37)
	bit 8	Control Command Selection Error (oFC38)
	bit 9	Drive timeout waiting for response (oFC39)
	bit A	Control Response Selection 1 Error (oFC40)
	bit B	Drive timeout waiting for response (oFC41)
	bit C	Control Response Selection 2 Error (oFC42)
	bit D	Control Response Selection Error (oFC43)
bit E, F	Reserved	
00E6H to 00FFH	Reserved	

- <1> Parameter o1-03, Digital Operator Display Selection, determines the units.
- <2> The number of decimal places in the parameter value depends on the drive model and the ND/HD selection in parameter C6-01. This value has two decimal places (0.01 A) if the drive is set for a maximum applicable motor capacity up to and including 11 kW, and one decimal place (0.1 A) if the maximum applicable motor capacity is higher than 11 kW.
- <3> Communication error contents are saved until the fault is reset.
- <4> Set the number of motor poles to parameter E2-04, E4-04, or E5-05 depending on the motor being used.
- <5> Terminals H1, H2, DM+, and DM- on 600 V class models are designed to the functionality, but are not certified to EN61800-5-1, ISO13849 Cat. 3, IEC/EN61508 SIL2, Insulation coordination: class 1.

### ◆ Broadcast Messages

Data can be written from the master to all slave devices at the same time.

The slave address in a broadcast command message must be set to 00H. All slaves will receive the message, but will not respond.

Register No.	Contents	
0001H	Digital Input Command	
	bit 0	Forward Run (0: Stop 1: Run)
	bit 1	Direction Command (0: Forward, 1: Reverse)
	bit 2, 3	Reserved
	bit 4	External Fault
	bit 5	Fault Reset
	bit 6 to B	Reserved
	bit C	Multi-Function Digital Input S5
	bit D	Multi-Function Digital Input S6
	bit E	Multi-Function Digital Input S7
	bit F	Multi-Function Digital Input S8
0002H	Frequency Reference	30000/100%

◆ **Fault Trace Contents**

The table below shows the fault codes that can be read out by MEMOBUS/Modbus commands from the U2-□□ monitor parameters.

**Table B.4 Fault Trace / History Register Contents**

Fault Code	Fault Name	Fault Code	Fault Name
0001H	Blown Fuse (PUF)	0043H	External Fault 2, Input Terminal S2 (EF2)
0002H	Undervoltage (Uv1)	0044H	Mechanical Weakening Detection 1 (oL5)
0003H	Control Power Supply Undervoltage (Uv2)	0045H	Mechanical Weakening Detection 2 (UL5)
0004H	Soft Charge Circuit Fault (Uv3)	0046H	Current Offset Fault (CoF)
0006H	Ground Fault (GF)	0047H	PLC Detection Error 1 (PE1)
0007H	Overcurrent (oC)	0048H	PLC Detection Error 2 (PE2)
0008H	Overvoltage (ov)	0049H	DriveWorksEZ Fault (dWFL)
0009H	Heatsink Overheat (oH)	004DH	Output Voltage Detection Fault (voF)
000AH	Heatsink Overheat (oH1)	0050H	Motor Overheat (NTC Input) ( oH5)
000BH	Motor Overload (oL1)	0052H	Node Setup Fault (nSE)
000CH	Drive Overload (oL2)	0053H	Thermistor Disconnect (THo)
000DH	Overtorque Detection 1 (oL3)	0060H	Current Unbalance (UnbC)
000EH	Overtorque Detection 2 (oL4)	0061H	Power Supply Module Undervoltage (Uv4)
000FH	Dynamic Braking Transistor (tr)	0062H	Uv5□MC/FANPower failure□
0010H	Braking Resistor Overheat (rH)	0063H	oH6□Thermal converter□
0011H	External Fault at Input Terminal S3 (EF3)	0064H	dFAn□FAN abnormal diode module□
0012H	External Fault at Input Terminal S4 (EF4)	0065H	EFAn (Abnormal FAN panel□
0013H	External Fault at Input Terminal S5 (EF5)	0083H	A/D Conversion Error (CPF02)
0014H	External Fault at Input Terminal S6 (EF6)	0084H	PWM Data Fault (CPF03)
0015H	External Fault at Input Terminal S7 (EF7)	0087H	EEPROM Memory Data Error (CPF06)
0016H	External Fault at Input Terminal S8 (EF8)	0088H	Terminal Board Connection Error (CPF07)
0017H	Drive Cooling Fan Failure (FAn)	0089H	EEPROM Serial Communication Fault (CPF08)
0018H	Overspeed (oS)	008CH	RAM Fault (CPF11)
0019H	Excessive Speed Deviation (dEv)	008DH	Flash Memory Circuit Exception (CPF12)
001AH	PG Disconnect (PGo)	008EH	Watchdog Circuit Exception (CPF13)
001BH	Input Phase Loss (PF)	008FH	Control Circuit Fault (CPF14)
001CH	Output Phase Loss (LF)	0091H	Clock Fault (CPF16)
001DH	Motor Overheat (PTC input) (oH3)	0092H	Timing Fault (CPF17)
001EH	Digital Operator Connection (oPr)	0093H	Control Circuit Fault (CPF18)
001FH	EEPROM Write Error (Err)	0094H	Control Circuit Fault (CPF19)
0020H	Motor Overheat (PTC input) (oH4)	0095H	Hardware Fault at Power Up (CPF20)
0021H	MEMOBUS/Modbus Communication Error (CE)	0096H	Hardware Fault at Communication Start Up (CPF21)
0022H	Option Communication Error (bUS)	0097H	A/D Conversion Fault (CPF22)
0025H	Control Fault (CF)	0098H	PWM Feedback Fault (CPF23)
0026H	Zero-Servo Fault (SvE)	0099H	Drive Unit Signal Fault (CPF24)
0027H	Option External Fault (EF0)	009BH	ASIC BB Circuit Error (CPF26)
0028H	PID Feedback Loss (FbL)	009CH	ASIC PWM Setting Register Error (CPF27)
0029H	Undertorque Detection 1 (UL3)	009DH	ASIC PWM Pattern Error (CPF28)
002AH	Undertorque Detection 2 (UL4)	009EH	ASIC On-delay Error (CPF29)
0030H	Hardware Fault (including oFx)	009FH	ASIC BBON Error (CPF30)
0036H	Output Current Imbalance (LF2)	00A0H	ASIC Code Error (CPF31)
0038H	PG Hardware Fault (PGoH)	00A1H	ASIC Start-up Error (CPF32)
003BH	Too Many Speed Search Restarts (SEr)	00A2H	Watch-dog Error (CPF33)
0041H	PID Feedback Loss (FbH)	00A3H	ASIC Power/Clock Error (CPF34)
0042H	External Fault 1, Input Terminal S1 (EF1)	00A4H	External A/D Converter Error (CPF35)

## B.9 MEMOBUS/Modbus Data Table

Fault Code	Fault Name
00A9H	Control Circuit Error (CPF40)
00AAH	Control Circuit Error (CPF41)
00ABH	Control Circuit Error (CPF42)
00ACH	Control Circuit Error (CPF43)
00ADH	Control Circuit Error (CPF44)
00AEH	Control Circuit Error (CPF45)
0101H	Option Compatibility Error (oFA00)
0102H	Option Not Properly Connected (oFA01)
0103H	Same Type of Option Card Already Connected (oFA02)
0106H	A/D Conversion Error (oFA05)
0107H	Option Response Error (oFA06)
0111H	Option RAM Fault (oFA10)
0112H	Option Operation Mode Fault (SLMOD) (oFA11)
0113H	Drive Receive CRC Error (oFA12)
0114H	Drive Receive Frame Error (oFA13)
0115H	Drive Receive Abort Error (oFA14)
0116H	Option Receive CRC Error (oFA15)
0117H	Option Receive Frame Error (oFA16)
0118H	Option Receive Abort Error (oFA17)
0131H	Comm. ID Error (oFA30)
0132H	Model Code Error (oFA31)
0133H	Sumcheck Error (oFA32)
0134H	Comm. Option Timeout Waiting for Response (oFA33)
0135H	MEMOBUS Timeout (oFA34)
0136H	Drive Timeout Waiting for Response (oFA35)
0137H	CI Check Error (oFA36)
0138H	Drive Timeout Waiting for Response (oFA37)
0139H	Control Command Selection Error (oFA38)
013AH	Drive Timeout Waiting for Response (oFA39)
013BH	Control Response Selection 1 Error (oFA40)
013CH	Drive Timeout Waiting for Response (oFA41)
013DH	Control Response Selection 2 Error (oFA42)

Fault Code	Fault Name
013EH	Control Response Selection Error (oFA43)
0201H	Option Connection Error (oFb01)
0202H	Same Type of Option Card Already Connected (oFb02)
0205H	A/D Conversion Error (oFb05)
0206H	Option Response Error (oFb06)
0210H	Option RAM Fault (oFb10)
0211H	Option Operation Mode Fault (SLMOD) (oFb11)
0212H	Drive Receive CRC Error (oFb12)
0213H	Drive Receive Frame Error (oFb13)
0214H	Drive Receive Abort Error (oFb14)
0215H	Option Receive CRC Error (oFb15)
0216H	Option Receive Frame Error (oFb16)
0217H	Option Receive Abort Error (oFb17)
0231H	Comm. ID Error (oFb30)
0232H	Model Code Error (oFb31)
0233H	Sumcheck Error (oFb32)
0234H	Comm. option Timeout Waiting for Response (oFb33)
0235H	MEMOBUS Timeout (oFb34)
0236H	Drive Timeout Waiting for Response (oFb35)
0237H	CI Check Error (oFb36)
0238H	Drive Timeout Waiting for Response (oFb37)
0239H	Control Command Selection Error (oFb38)
023AH	Drive Timeout Waiting for Response (oFb39)
023BH	Control Response Selection 1 Error (oFb40)
023CH	Drive Timeout Waiting for Response (oFb41)
023DH	Control Response Selection 2 Error (oFb42)
023EH	Control Response Selection Error (oFb43)
0300H	Option Compatibility Error (oFC00)
0301H	Option Not Properly Connected (oFC01)
0302H	Same Type of Option Card Already Connected (oFC02)
0305H	A/D Conversion Error (oFC05)
0306H	Option Response Error (oFC06)

## ◆ Alarm Register Contents

The table below shows the alarm codes that can be read out from MEMOBUS/Modbus register 007FH.

**Table B.5 Alarm Register 007FH Contents**

Fault Code	Fault Name	Fault Code	Fault Name
0001H	Undervoltage (Uv)	0022H	Motor Overheat (oH3)
0002H	Overvoltage (ov)	0027H	PID Feedback Loss (FbL)
0003H	Heatsink Overheat (oH)	0028H	PID Feedback Loss (FbH)
0004H	Drive Overheat (oH2)	002AH	Drive Disabled (dnE)
0005H	Overtorque 1 (oL3)	002BH	PG Disconnected (PGo)
0006H	Overtorque 2 (oL4)	0031H	SI-T3 Watchdog Error (E5)
0007H	Run commands input error (EF)	0032H	SI-T3 Station Address Setting Error (AEr)
0008H	Drive Baseblock (bb)	0033H	SI-T3 Comm. Cycle Setting Error (CyC)
0009H	External Fault 3, input terminal S3 (EF3)	0034H	High Current Alarm (HCA)
000AH	External Fault 4, input terminal S4 (EF4)	0035H	Cooling Fan Maintenance Time (LT-1)
000BH	External Fault 5, input terminal S5 (EF5)	0036H	Capacitor Maintenance Time (LT-2)
000CH	External Fault 6, input terminal S6 (EF6)	0038H	SI-S EEPROM Error (EEP)
000DH	External Fault 7, input terminal S7 (EF7)	0039H	External Fault (input terminal S1) (EF1)
000EH	External Fault 8, input terminal S8 (EF8)	003AH	External Fault (input terminal S2) (EF2)
000FH	Cooling Fan Error (FAN)	003BH	Safe Disable Input (HbbF) </>
0010H	Overspeed (oS)	003CH	Safe Disable Input (Hbb) </>
0011H	Excessive Speed Deviation (dEv)	003DH	Mechanical Weakening Detection 1 (oL5)
0012H	PG Disconnected (PGo)	003EH	Mechanical Weakening Detection 2 (UL5)
0014H	MEMOBUS/Modbus Communication Error (CE)	003FH	PLC Alarm (PA1)
0015H	Option Communication Error (bUS)	0040H	PLC Alarm (PA2)
0016H	Serial Communication Transmission Error (CALL)	0041H	Output Voltage Detection Fault (voF)
0017H	Motor Overload (oL1)	0042H	IGBT Maintenance Time (90%) (TrPC)
0018H	Drive Overload (oL2)	0043H	Soft Charge Bypass Relay Maintenance Time (LT-3)
001AH	Option Card External Fault (EF0)	0044H	IGBT Maintenance Time (50%) (LT-4)
001BH	Motor Switch command input during run (rUn)	0048H	Motor Overheat (NTC Input) (oH5)
001DH	Serial Communication Transmission Error (CALL)	0049H	DriveWorksEZ Alarm (dWAL)
001EH	Undertorque Detection 1 (UL3)	004DH	Thermistor Disconnect (THo)
001FH	Undertorque Detection 2 (UL4)		
0020H	MEMOBUS/Modbus Test Mode Fault (SE)		

<1> Terminals H1, H2, DM+, and DM- on 600 V class models are designed to the functionality, but are not certified to EN61800-5-1, ISO13849 Cat. 3, IEC/EN61508 SIL2, Insulation coordination: class 1.

# B.10 Enter Command

When writing parameters to the drive from the PLC using MEMOBUS/Modbus communication, parameter H5-11 determines whether an Enter command must be issued to enable these parameters. This section describes the types and functions of the Enter commands.

## ◆ Enter Command Types

The drive supports two types of Enter commands as shown in [Table B.6](#). An Enter command is enabled by writing 0 to register numbers 0900H or 0910H. It is only possible to write to these registers; attempting to read from these registers will cause an error.

**Table B.6 Enter Command Types**

Register No.	Description
0900H	Simultaneously writes data into the EEPROM (non-volatile memory) of the drive and enables the data in RAM. Parameter changes remain after cycling power.
0910H	Writes data in the RAM only. Parameter changes are lost when the drive is shut off.

**Note:** The EEPROM can only be written to 100,000 times, so it is recommended to limit the number of times writing to the EEPROM. The Enter command registers are write-only and if these registers are read, the register address will be invalid (Error code: 02H). An Enter command is not required when reference or broadcast data are sent to the drive.

## ◆ Enter Command Settings when Upgrading the Drive

When replacing previous Yaskawa drive models with the A1000 and keeping the MEMOBUS/Modbus communications settings, set parameter H5-11 in accordance with the Enter command configuration in the older drive. H5-11 determines whether an Enter command is necessary to activate parameter changes in the drive.

- If upgrading from a G7 or F7 series drive to an A1000, set parameter H5-11 to 0.
- If upgrading from a V7 series drive to an A1000, set parameter H5-11 to 1.

## ■ H5-11 and the Enter Command

An enter command is not required when writing registers 0000H to 001FH. Changes to those registers take effect immediately, independent of the setting in parameter H5-11.

H5-11 Settings	H5-11 = 0	H5-11 = 1
Drive being replaced	G7, F7	V7
How parameter settings are enabled	When the Enter command is received from the master.	As soon as the value is changed.
Upper/lower limit check	Upper/lower limit check is performed, taking the settings of related parameters into account.	Checks only the upper/lower limits of the parameters that were changed.
Default value of related parameters	Not affected. The settings of related parameters remain unchanged. They must be changed manually if needed.	Default settings of related parameters are changed automatically.
Error handling when setting multiple parameters	Data is accepted even if one setting is invalid. The invalid setting will be discarded. No error message occurs.	Error occurs if only one setting is invalid. All data that was sent are discarded.



## B.11 Communication Errors

### ◆ MEMOBUS/Modbus Error Codes

A list of MEMOBUS/Modbus errors appears below.

When an error occurs, remove whatever caused the error and restart communications.

Error Code	Error Name
	Cause
01H	Function Code Error
	<ul style="list-style-type: none"> <li>Attempted to set a function code from a PLC other than 03H, 08H, and 10H.</li> </ul>
02H	Register Number Error
	<ul style="list-style-type: none"> <li>A register number specified in the command message does not exist.</li> <li>Attempted to send a broadcast message using other register numbers than 0001H or 0002H.</li> </ul>
03H	Bit Count Error
	<ul style="list-style-type: none"> <li>Read data or write data is greater than 16 bits. Invalid command message quantity.</li> <li>In a write message, the “Number of Data Items” contained within the message does not equal twice the amount of data words (i.e., the total of Data 1+ Data 2, etc.).</li> </ul>
21H	Data Setting Error
	<ul style="list-style-type: none"> <li>Control data or parameter write data is outside the allowable setting range.</li> <li>Attempted to write a contradictory parameter setting.</li> </ul>
22H	Write Mode Error
	<ul style="list-style-type: none"> <li>During run, the user attempted to write a parameter that cannot be written to during run.</li> <li>During an EEPROM memory data error (CPF06), the master attempted to write to a parameter other than A1-00 to A1-05, E1-03, or o2-04.</li> <li>Attempted to write to read-only data.</li> </ul>
23H	DC Bus Undervoltage Write Error
	<ul style="list-style-type: none"> <li>During an undervoltage situation, the master attempted to write to parameters that cannot be written to during undervoltage.</li> </ul>
24H	Write Error During Parameter Process
	<ul style="list-style-type: none"> <li>Master attempted writing to the drive while the drive was processing parameter data.</li> </ul>

### ◆ Slave Not Responding

In the following situations, the slave drive will ignore the command message sent from the master, and not send a response message:

- When a communications error (overrun, framing, parity, or CRC-16) is detected in the command message.
- When the slave address in the command message and the slave address in the drive do not match (remember to set the slave address for the drive using H5-01).
- When the gap between two blocks (8-bit) of a message exceeds 24 bits.
- When the command message data length is invalid.

**Note:** If the slave address specified in the command message is 00H, all slaves execute the write function, but do not return response messages to the master.

## B.12 Self-Diagnostics

The drive has a built-in self-diagnosing function of the serial communication interface circuits. To perform the self-diagnosis function, use the following procedure.

**DANGER! Electrical Shock Hazard.** Do not connect or disconnect wiring while the power is on. Failure to comply will result in death or serious injury. Before servicing, disconnect all power to the equipment. The internal capacitor remains charged even after the power supply is turned off. The charge indicator LED will extinguish when the DC bus voltage is below 50 Vdc. To prevent electric shock, wait at least one minute after all indicators are OFF and measure the DC bus voltage level to confirm safe level.

1. Turn on the power to the drive.
2. Note the present terminal S6 function selection setting (H1-06) and set it for the communications test mode (H1-06 = 67).
3. Turn off the power to the drive.
4. With the power off, wire the drive as shown in the following diagram, connecting terminals R+ and S+, R- and S-, and S6 and SC.

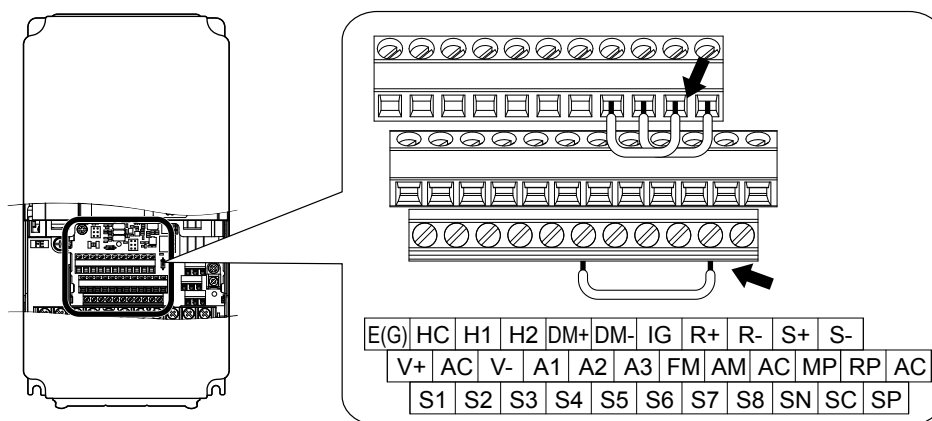

Figure B.9 Terminal Connections for Communication Self-Diagnostics

5. Set jumper S3 to source mode (internal power supply).
6. Turn the power to the drive back on.
7. During normal operation, the drive will display “Pass” to indicate that the communications test mode is operating normally.

When a fault occurs, the drive will display “CE” on the keypad display.

8. Turn off the power supply.
9. Remove the wire jumpers from terminal R+, R-, S+, S-, and S6-SC. Reset jumper S3 to its original position and set terminal S6 to its original function.
10. Return to normal operation.

# Index

## Numerics

2-Wire Initialization .....	11
3-Wire Initialization .....	11
3-Wire Sequence .....	11
3-Wire Sequence Wiring Diagram .....	95
5th Most Recent Fault .....	300

## A

A/D Conversion Error .....	183
A1-02 .....	226
A1-02 (Motor 1 Control Mode) Dependent Parameters .....	305
A1-04 .....	224
A1-04, A1-05: Password and Password Setting .....	11
A1-05 .....	224
Abnormal Diode Module Fan .....	184, 203
Abnormal Panel Fan .....	186, 203
Accel/Decel Time .....	176
Accel/Decel Time Setting Units .....	48
Accel/Decel Time Switching Frequency .....	47
Acceleration Error .....	216
Acceleration Time .....	46
Access Level Selection .....	10
Action Selection below Minimum Output Frequency .....	22
Adjusted Slip Calculation Error .....	214
Adjusting the ASR Parameters .....	53
AEr .....	201
AFR .....	156
AFR Gain .....	175
AFR Time Constant 1 .....	175
AFR Time Constant 2 .....	175
AI-A3 Settings .....	86
Alarm Register 007FH Contents .....	343
Alarms and Errors .....	177
Ambient Temperature Setting .....	152, 286
Analog Filter Time Constant .....	176
Analog Frequency Reference Fluctuation Limit .....	67
Analog Frequency Reference Sample/Hold .....	100
Analog Input Card Settings .....	86
Analog Input Filter Time Constant .....	116
Analog Input Option Card Bias .....	87
Analog Input Option Card Gain .....	87
Analog Input Option Card Operation Selection .....	86
Analog Input Terminal Enable Selection .....	117
Analog Monitor Card Settings .....	87
AO-A3 Settings .....	87
ASR .....	53
ASR Gain Switching Frequency .....	55

ASR Integral Limit .....	56
ASR Integral Time .....	55
ASR Limit .....	56
ASR Primary Delay Time Constant .....	56
ASR Proportional Gain .....	55
ASR Response Frequency .....	167
Automatic Reduction Selection for Stall Prevention during Run ...	142, 283
Automatic Speed Regulator .....	53
Auto Restart Fault Output Operation Selection .....	145
Auto Restart Operation Selection .....	284
Auto-Tuning Codes .....	214
Auto-Tuning Errors .....	180
Auto-Tuning Fault Detection .....	214
Auto-Tuning Fault Solutions .....	214
Auto-Tuning Mode Selection .....	165, 294

## B

b1-01 .....	224
b1-02 .....	224
b1-04 .....	225
b2-02 .....	229
b2-04 .....	229
b5-09 .....	229
b6-01 through b6-04 .....	176
Baseblock .....	201
Base Frequency .....	76
Base Voltage .....	76
bb .....	201
Bi-Directional Speed Search Selection .....	31
boL .....	182, 201
Braking Resistor Fault .....	196
Braking Resistor Overheat .....	197
Braking Transistor Overload Fault .....	182, 201
Broadcast Messages .....	340
bUS .....	182, 201
bUS Error Detection Time .....	90

## C

C2-01 through C2-04 .....	176
C3-01 .....	174, 175
C3-02 .....	175
C4-01 .....	174
C4-02 .....	174, 175
C4-06 .....	175
C6-01 .....	174
C6-02 .....	174, 175, 228
C6-05 .....	228

CALL.....	202	Copy Allowed Selection.....	162
Cannot Change Parameter Settings.....	223	Copy Function.....	162
Cannot Reset.....	202	Copy Function Errors.....	177
CANopen Communication Speed.....	92	Copy Function Selection.....	162
CANopen Node ID Selection.....	91	Copy Unit Error.....	219
CANopen Parameters.....	89, 91	CPEr.....	219
Capacitor Maintenance.....	300	CPF02.....	183
Capacitor Maintenance Setting.....	163, 291	CPF03.....	183
Capacitor Maintenance Time.....	205	CPF06.....	183
Carrier Frequency.....	57	CPF07.....	183
Carrier Frequency Proportional Gain.....	58	CPF08.....	183
Carrier Frequency Reduction.....	287	CPF11 to CPF14.....	183
Carrier Frequency Reduction Off-Delay Time.....	154	CPF16 to CPF19.....	183
Carrier Frequency Reduction Selection.....	153	CPF20.....	183
Carrier Frequency Selection.....	58, 174, 175	CPF21.....	183
Carrier Frequency Setting Error.....	213	CPF22.....	184
CC-Link bUS Error Auto Reset.....	91	CPF23.....	184
CC-Link Communication Speed.....	91	CPF24.....	184
CC-Link Node Address.....	90	CPF26 to CPF34.....	184
CC-Link Parameters.....	89, 90	CPyE.....	219
CE.....	182, 202	CRC-16.....	324
CE Detection Time.....	123, 320	CRC-16 Checksum Calculation Example.....	325
CF.....	182	CrST.....	202
Coast to stop.....	20	CSEr.....	219
Coast to Stop with Timer.....	21	Cumulative Operation Time.....	300
Comm. option card connection error (CN5-A).....	190	Cumulative Operation Time at 5th Most Recent Fault.....	300
Command Messages from Master to Drive.....	323	Cumulative Operation Time at Most Recent Fault.....	300
Communication Error.....	219	Cumulative Operation Time at Previous Fault.....	299
Communication Fault Detection Selection.....	122, 319	Cumulative Operation Time Selection.....	163, 291
Communication Option Card.....	89	Cumulative Operation Time Setting.....	163, 291
Communication Option Card Reference.....	302	Current Alarm.....	205
Communication Option Station Number Setting Error (CC-Link, CANopen, MECHATROLINK-II).....	201	Current Detection Error.....	216
Communication Parity Selection.....	122, 319	Current Detection Speed Search.....	27
Communications Enter Function Selection.....	123, 320	Current Fault.....	298
Communications Error Operation Selection.....	89	Current Unbalance.....	198
Communication Speed Selection.....	121, 319	Cyclic Redundancy Check.....	324
Communications Timing.....	323		
Comparing Parameter Settings.....	220	<b>D</b>	
Compressor Application.....	16	d2-01.....	229
Connected Machinery Vibrates When Motor Rotates.....	228	d3-01.....	228
Connection of a Motor PTC.....	128	d3-01 through d3-04.....	176
Continuous Electrothermal Operation Selection.....	129, 280	d3-04.....	228
Control Board Connection Error.....	183, 184	d-Axis ACR Output.....	303
Control Circuit Error.....	183, 184	DC Bus Overvoltage.....	207
Control Fault.....	182	DC Bus Pre-Charge Relay Maintenance Setting.....	163
Control Method Selection.....	10	DC Bus Undervoltage.....	198
Control Method Selection Error.....	211	DC Bus Voltage.....	296
Control Mode.....	10, 296	DC Bus Voltage at Previous Fault.....	299
Control Mode Dependent Parameter Default Values.....	305	DC Bus Voltage Setpoint during KEB.....	138
Control Mode Mismatch.....	219	DC Injection Braking at Stop.....	229
Control Power Supply Voltage Fault.....	199	DC Injection Braking Current.....	26, 229
Converter Heating.....	193	DC Injection Braking Input Timing Diagram.....	102
Conveyor Application.....	14	DC Injection Braking Start Frequency.....	20
Cooling Fan Maintenance.....	300	DC Injection Braking Time at Start.....	20
Cooling Fan Maintenance Setting (Operation Time).....	291	DC Injection Braking Time at Stop.....	26
Cooling Fan Maintenance Time.....	205	DC Injection Braking to Stop.....	20
Cooling Fan Operation Time.....	300	D Control.....	33
Cooling Fan Operation Time Setting.....	163	Deceleration Time.....	46
CoPy.....	219	Deceleration Time at Stall Prevention during Acceleration.....	139, 283
		Defaults by Drive Model Selection (o2-04) and ND/HD (C6-01).....	161

Delay Timers .....	32	Dwell Reference at Start .....	43
Derivative Time (D) .....	36	Dwell Reference at Stop .....	43
Desired DC Bus Voltage during KEB .....	281	Dwell Time at Start .....	43
dEv .....	184, 202	Dwell Time at Stop .....	43
DeviceNet Baud Rate Monitor .....	93	DWEZ Version Control Monitor 1 to 3 .....	304
DeviceNet Communication Speed .....	92	dWFL .....	186
DeviceNet Heartbeat Interval .....	93	Dynamic Braking Transistor .....	197
DeviceNet Idle Mode Fault Detection .....	92	<b>E</b>	
DeviceNet MAC Address .....	92	E1-03 .....	226
DeviceNet Network MAC ID .....	93	E1-04 .....	226, 229
DeviceNet Parameters .....	89, 92	E1-08 .....	174, 175
DeviceNet PCA Setting .....	92	E1-09 .....	224
DeviceNet PPA Setting .....	92	E1-10 .....	174, 175
DeviceNet Scaling Factors .....	93	E2-01 .....	174
dFAn .....	184, 203	E2-02 .....	174
dFPS .....	219	E2-03 .....	174, 215
DI-A3 Settings .....	87	E3-01 (Motor 2 Control Mode) Dependent Parameters .....	307
Diagnosing and Resetting Faults .....	188	E5 .....	186
Digital Input Card Settings .....	87	EEPROM Memory Data Error .....	183
Digital Input Option Card Input Selection .....	87	EEPROM Write Error .....	187
Digital Input Option DI-A3 Data Length Selection .....	87	EF .....	203
Digital Input Reading .....	23	EF0 .....	186, 203
Digital Operator Display Selection .....	159, 290	EF1 .....	186, 203
Digital Operator Keypad Functions .....	160	EF2 .....	186, 203
Digital Output Card Settings .....	88	EF3 .....	186, 203
Digital Output Option Card Terminal Function Selection .....	88	EF4 .....	186, 203
dnE .....	203	EF5 .....	186, 204
DO-A3 Output Mode Selection .....	89	EF6 .....	186, 204
DO-A3 Settings .....	88	EF7 .....	186, 204
Drive/kVA Selection .....	290	EF8 .....	186, 204
Drive Capacity Setting Fault .....	210	EFAn .....	186, 203
Drive Disabled .....	203	End .....	219
Drive Does Not Allow Selection of Rotational Auto-Tuning .....	226	End1 .....	214
Drive Duty Mode Selection .....	57	End2 .....	214
Drive Model Mismatch .....	219	End3 .....	214
Drive Model Selection .....	161	End4 .....	214
Drive Mode Unit Monitor Selection .....	159, 290	End5 .....	214
Drive Operation Status at Previous Fault .....	299	End6 .....	214
Drive Overheat Warning .....	206	End7 .....	215
Drive Overload .....	193	Energy Savings Constants Error .....	213
Drive Slave Address .....	121, 319	Enter Command .....	123
Drive Status .....	297	Enter command necessary .....	123, 321
Drive Transmit Wait Time .....	122, 320	Enter command not necessary .....	123, 321
Drive Unit Signal Fault .....	184	Enter Command Settings when Upgrading the Drive .....	344
DriveWorksEZ Connection Parameters .....	164	Enter Command Types .....	344
DriveWorksEZ Custom Monitor 1 to 10 .....	304	Er-01 .....	215
DriveWorksEZ Fault .....	186	Er-02 .....	215
DriveWorksEZ Function Selection .....	16	Er-03 .....	215
DriveWorksEZ Monitors .....	170	Er-04 .....	215
DriveWorksEZ Parameters .....	164	Er-05 .....	215
Droop Control Delay Time .....	44	Er-08 .....	216
Droop Control Gain .....	43	Er-09 .....	216
During Frequency Output Time Chart .....	113	Er-10 .....	216
During Run Time Chart .....	105	Er-11 .....	216
dv1 .....	185	Er-12 .....	216
dv2 .....	185	Er-13 .....	217
dv3 .....	185	Er-14 .....	217
dv4 .....	185	Er-15 .....	217
dWAL .....	186	Er-16 .....	217
Dwell Function .....	42, 176		

Er-17.....	217	Frequency Reference Bias (Up/Down 2).....	304
Er-18.....	217	Frequency Reference Bias Accel/Decel.....	66
Er-19.....	217	Frequency Reference Bias Lower Limit.....	65
Er-20.....	217	Frequency Reference Bias Operation Mode Selection.....	66
Er-21.....	218	Frequency Reference Bias Step.....	65
Err.....	187	Frequency Reference Bias Upper Limit.....	65
Error Reading Data.....	220	Frequency Reference from MEMOBUS/Modbus Comm.....	301
Errors and Displays When Using the Copy Function.....	180	Frequency Reference Hold.....	63
Error Writing Data.....	219	Frequency Reference Hold Function Selection.....	63
Excessive Motor Oscillation and Erratic Rotation.....	227	Frequency Reference Loss Detection Selection.....	108, 283
Excessive PID Feedback.....	187, 204	Frequency Reference Lower Limit.....	61
Excessive Speed Deviation Detection Delay Time.....	85	Frequency Reference Monitor Content During PID.....	41
Excessive Speed Deviation Detection Level.....	85	Frequency Reference Selection.....	237
Excessive V/f Setting.....	214	Frequency Reference Selection 1.....	18, 224
Exhaust Fan Application.....	15	Frequency Reference Selection 2.....	24
External Digital Operator Connection Fault.....	194	Frequency Reference Setting / Decimal Display.....	290
External Fault.....	186, 203	Frequency Reference Setting and User-Set Display.....	290
External Fault from Comm. Option Detection Selection.....	89	Frequency Reference Setting Hierarchy.....	59
External Fault from Comm. Option Operation Selection.....	89	Frequency Reference Setting Method Selection.....	161, 291
<b>F</b>		Frequency Reference Source Selection.....	301
FAn.....	187	Frequency Reference Upper Limit.....	61
FAn Alarm Location Monitor.....	302	Function Code.....	324
Fast Stop Sequence.....	99	Functions for Terminals S1 to S8.....	94
Fast Stop Time.....	47	Fuse is Open.....	196
Fault Causes and Solutions.....	182	<b>G</b>	
Fault Detection.....	182	Gate Drive Board Undervoltage.....	199
Fault Displays.....	182	GF.....	187
Fault History.....	169, 221	Ground Fault.....	187
Fault Reset Interval Time.....	145, 284	<b>H</b>	
Fault Reset Methods.....	177	H1 Multi-Function Digital Input Selections.....	267
Fault Reset Operation Selection.....	146, 284	H3-02.....	227, 228, 229
Fault Restart.....	112	H3-10.....	228, 229
Faults.....	177	H3-11.....	229
Fault SlaveLocation Monitor.....	299	H3-13.....	176, 228
Fault Trace.....	169, 221	H3 Multi-Function Analog Input Settings.....	275
FbH.....	187, 204	Hbb.....	204
FbL.....	187, 204	HbbF.....	204
Feed Forward Control.....	176	HCA.....	205
Field Forcing.....	72	HD.....	58
Field Forcing Limit.....	73	Heatsink Cooling Fan Off-Delay Time.....	152
Field Forcing Selection.....	73	Heatsink Cooling Fan Operation Delay Time.....	286
Field Weakening.....	72	Heatsink Cooling Fan Operation Selection.....	152, 286
Field Weakening Frequency Limit.....	72	Heatsink Overheat.....	191, 206
Field Weakening Level.....	72	Heatsink Temperature.....	300
Fine-Tuning Open Loop Vector Control.....	175	Heavy Duty.....	58
Fine-Tuning V/f Control and V/f Control with PG.....	174	High Current Alarm Selection.....	154
FJOG/RJOG Operation.....	98	High Slip Braking.....	157
Forward/Reverse Run Command Input Error.....	203	High-slip Braking oL.....	194
Forward Regenerative Torque Limit.....	149, 285	High Slip Suppression Current Level.....	158
Forward Torque Limit.....	149, 285	High-Slip Suppression Current Level.....	289
Frequency Detection 1 Time Chart.....	107	HSB.....	157
Frequency Detection 2 Time Chart.....	107	Hunting Prevention.....	156
Frequency Detection 3 Example with a Positive L3-04 Value.....	110	Hunting Prevention Gain.....	174
Frequency Detection 4 Example with Positive L3-04 Value.....	111	Hunting Prevention Gain Setting.....	156, 288
Frequency Reduction Rate during Overheat Pre-Alarm.....	151, 287	Hunting Prevention Gain while in Reverse.....	156, 288
Frequency Reference.....	59, 296	Hunting Prevention Selection.....	156, 288
Frequency Reference at Previous Fault.....	298	Hunting Prevention Time Constant.....	156, 288
Frequency Reference at Reference Loss.....	144, 283	HVAC Fan Application.....	15
Frequency Reference Bias.....	65		

Hybrid IC Failure .....	184	L3-11 .....	176
<b>I</b>		L7-01 through L7-04 .....	176, 228
I Control.....	33	L7-06 .....	176
iFEr .....	219	L7-07 .....	176
IGBT Maintenance .....	300	L8-38 .....	229
IGBT Maintenance Setting .....	163, 291	Language Selection .....	10
IGBT Maintenance Time (50%) .....	205	Leakage Inductance Alarm .....	214
IGBT Maintenance Time (90%) .....	208	Leakage Inductance Error .....	217
IGBT Short Circuit or Ground Fault .....	197	LED Check .....	300
Induction Voltage Error.....	217	LF .....	188
Inertia Detection Error .....	217	LF2 .....	188
Inertia Tuning Frequency Reference .....	167	LF3 .....	188
Inertia Tuning Reference Amplitude .....	167	Line-to-Line Resistance Error.....	215
Initialization .....	10	LO/RE (LOCAL/REMOTE) Key Function Selection .....	24
Initialization Required .....	211	LOCAL/REMOTE Key Function Selection .....	290
Initialize Parameters.....	11	LOCAL/REMOTE Run Selection.....	24
Input Phase Loss .....	196	Loopback Test.....	326
Input Phase Loss Protection Selection .....	151, 286	Loss of Reference Function .....	144
Input Pulse Monitor .....	298	LT-1 .....	205
Input Terminal Status .....	296	LT-2 .....	205
Input Terminal Status at Previous Fault .....	299	LT-3 .....	205
Input Voltage Setting.....	74	LT-4 .....	205
Inrush Prevention Circuit Fault .....	199	<b>M</b>	
Inrush Prevention Relay Maintenance Setting .....	291	Magnetic Flux Compensation Value .....	27
Integral Limit Setting .....	36	Maintenance Monitors .....	169
Integral Operation during Accel/Decel .....	56	Maintenance Monitor Settings .....	163
Integral Operation during Accel/Decel for Motor 2.....	57	Master Speed Reference Lower Limit .....	62
Integral Time Setting (I) .....	36	Maximum Output Frequency.....	76
Inversion Detection .....	185	Maximum Voltage.....	76
Inversion Prevention Detection .....	185	MC/FAN power malfunction.....	199
<b>J</b>		Mechanical Weakening Detection .....	112
Jog Frequency Reference .....	59	Mechanical Weakening Detection 1 .....	194, 207
Jump Frequency.....	62, 176	Mechanical Weakening Detection 2 .....	198
Jump Frequency Width .....	62	Mechanical Weakening Detection Operation .....	148, 285
<b>K</b>		Mechanical Weakening Detection Speed Level .....	148, 285
KEB Acceleration Time .....	138, 281	Mechanical Weakening Detection Start Time .....	148, 285
KEB Detection Time .....	138	Mechanical Weakening Detection Time.....	148, 285
KEB Function Related Adjustments .....	137	MECHATROLINK-II Parameters .....	89
KEB Operation Using a KEB Input .....	134	MEMOBUS/Modbus Comm. Test Mode Complete .....	208
KEB Operation Using L2-02, Without KEB Input.....	134	MEMOBUS/Modbus Communication Error.....	182, 202
KEB Operation Using L2-02 and KEB Input .....	135	MEMOBUS/Modbus Communications Reference.....	301
KEB Operation Using L2-10, Without KEB Input.....	135	MEMOBUS/Modbus communication terminal and S2 DIP switch .....	318
KEB Operation Using L2-10 and KEB Input .....	136	MEMOBUS/Modbus Communication Test Mode Error.....	208
KEB Operation Wiring Example .....	136	MEMOBUS/Modbus Data Table.....	328
KEB Ride-Thru End Detection .....	134	MEMOBUS/Modbus Error Code .....	297
KEB Ride-Thru Function .....	102	MEMOBUS/Modbus Error Codes .....	345
KEB Ride-Thru Start .....	133	MEMOBUS/Modbus Setup Parameters .....	319
kWh.....	301	MEMOBUS/Modbus Specifications .....	315
kWh, Lower 4 Digits .....	301	Message Format .....	324
kWh, Upper 5 Digits .....	301	MessageID (INV).....	298
kWh Monitor Initialization .....	164	MessageID (OPR) .....	298
kWh Monitor Initial Value Selection .....	292	Middle Output Frequency .....	76
<b>L</b>		Middle Output Frequency 2 .....	76
L3-01 through L3-06 .....	176	Middle Output Frequency Voltage .....	76
L3-02 .....	227, 229	Middle Output Frequency Voltage 2.....	76
L3-04 .....	227	Mid Output Voltage A .....	174
L3-06 .....	227	Minimum KEB Time.....	138
		Minimum Output Frequency .....	76
		Minimum Output Frequency Voltage.....	76

Minimum Output Voltage .....	174	Motor Inertia .....	167
Minimum Wait Time for Sending Messages .....	323	Motor Iron-Core Saturation Coefficient .....	214
Minor Alarms .....	177	Motor Iron-Core Saturation Coefficient 1 .....	78
Minor Fault .....	215	Motor Iron-Core Saturation Coefficient 2 .....	78
Minor Fault and Alarm Displays .....	179	Motor Iron Loss .....	167, 295
Minor Faults .....	177	Motor Iron Loss for Torque Compensation .....	79
Minor Faults and Alarms .....	177	Motor is Too Hot .....	225
Model, Voltage Class, Capacity Mismatch .....	220	Motor Leakage Inductance .....	78
Momentary Power Loss Minimum Baseblock Time .....	137, 281	Motor Line-to-Line Resistance .....	78
Momentary Power Loss Operation Selection .....	30, 281	Motor Mechanical Loss .....	78
Momentary Power Loss Ride-Thru .....	132	Motor No-Load Current .....	77, 166
Momentary Power Loss Ride-Thru Time .....	137, 281	Motor Overheat .....	206
Momentary Power Loss Voltage Recovery Ramp Time .....	138, 281	Motor Overheat (NTC Input) .....	192, 206
Monitor Parameters .....	120, 296	Motor Overheat Alarm (PTC Input) .....	192
Most Recent Fault .....	300	Motor Overheat Alarm Operation Selection .....	129, 280
Motor 1/Motor 2 Selection .....	165	Motor Overheat Fault (PTC Input) .....	192
Motor 1 Parameters .....	77	Motor Overheat Fault Operation Selection .....	129, 280
Motor 2 ASR Gain Switching Frequency .....	57	Motor Overload .....	193
Motor 2 ASR Integral Limit .....	57	Motor Overload Estimate (oL1) .....	301
Motor 2 ASR Integral Time .....	57	Motor Overload Protection Selection .....	112, 280
Motor 2 ASR Limit .....	57	Motor Overload Protection Time .....	128, 280
Motor 2 ASR Primary Delay Time Constant .....	57	Motor Parameters .....	74
Motor 2 ASR Proportional Gain .....	57	Motor Performance Fine-Tuning .....	174
Motor 2 Base Frequency .....	80	Motor Produces Insufficient Torque .....	229
Motor 2 Base Voltage .....	80	Motor Protection .....	126
Motor 2 Control Mode Selection .....	80	Motor Protection Using a Positive Temperature Coefficient Thermistor .....	119
Motor 2 Iron Loss .....	82	Motor PTC Characteristics .....	129
Motor 2 Leakage Inductance .....	82	Motor q-Axis Current at Previous Fault .....	299
Motor 2 Line-to-Line Resistance .....	82	Motor Rated Current .....	77, 166, 294
Motor 2 Max Output Frequency .....	80	Motor Rated Power .....	79, 165, 294
Motor 2 Max Voltage .....	80	Motor Rated Slip .....	77, 166
Motor 2 Mechanical Loss .....	82	Motor Rated Voltage .....	165, 294
Motor 2 Mid Output Frequency .....	80	Motor Rotates After the Drive Output is Shut Off .....	229
Motor 2 Mid Output Frequency 2 .....	80	Motor Rotates Faster Than the Frequency Reference .....	227
Motor 2 Mid Output Frequency Voltage .....	80	Motor Rotates in One Direction Only .....	225
Motor 2 Mid Output Frequency Voltage 2 .....	80	Motor Secondary Current (Iq) .....	303
Motor 2 Minimum Output Frequency .....	80	Motor Selection .....	99
Motor 2 Minimum Output Frequency Voltage .....	80	Motor Selection 1/2 .....	294
Motor 2 Motor Iron-Core Saturation Coefficient 1 .....	82	Motor Speed .....	296
Motor 2 Motor Iron-Core Saturation Coefficient 2 .....	82	Motor Speed at Previous Fault .....	298
Motor 2 Motor Poles .....	82	Motor Speed Error 2 .....	217
Motor 2 Parameters .....	81	Motor Speed Fault .....	216
Motor 2 Rated Current .....	81	Motor Stalls During Acceleration or With Large Loads .....	226
Motor 2 Rated No-Load Current .....	81	Motor Switch during Run .....	208
Motor 2 Rated Power .....	83	Motor Temperature (NTC) .....	302
Motor 2 Rated Slip .....	81	Motor Temperature Input Filter Time .....	129, 280
Motor 2 Slip Compensation Gain .....	50	Multi-Function Analog Inputs .....	68
Motor 2 Slip Compensation Limit .....	51	Multi-Function Analog Input Selection Error .....	211
Motor 2 Slip Compensation Primary Delay Time .....	50	Multi-Function Analog Input Terminal Settings .....	114
Motor 2 Slip Compensation Selection during Regeneration .....	51	Multi-Function Analog Outputs .....	53
Motor 2 Torque Compensation Gain .....	52	Multi-Function Analog Output Terminal AM Bias .....	120
Motor Base Frequency .....	166, 294	Multi-Function Analog Output Terminal AM Gain .....	120
Motor Base Speed .....	166, 294	Multi-Function Analog Output Terminal AM Monitor Selection .....	120
Motor Data Error .....	215	Multi-Function Analog Output Terminal AM Signal Level Selection .....	121
Motor d-Axis Current at Previous Fault .....	299	Multi-Function Analog Output Terminal FM Bias .....	120
Motor Direction at Power Up when Using Operator .....	162, 291	Multi-Function Analog Output Terminal FM Gain .....	120
Motor Direction Error .....	216	Multi-Function Analog Output Terminal FM Monitor Selection .....	120
Motor Does Not Rotate .....	224		
Motor Excitation Current (Id) .....	303		
Motor Hunting and Oscillation Control Parameters .....	176		



Multi-Function Analog Output Terminal FM Signal Level Selection .....	121	oL1 .....	193
Multi-Function Digital Inputs .....	94	oL2 .....	193, 229
Multi-Function Digital Input Terminal Settings .....	94	oL2 Characteristics Selection at Low Speeds .....	153, 286
Multi-Function Digital Outputs .....	104	oL3 .....	194, 207
Multi-Function Digital Output Terminal Settings .....	104	oL4 .....	194, 207
Multi-Function Input Selection Error .....	210	oL5 .....	194, 207
Multi-Step Speed Selection .....	19	oL7 .....	194
<b>N</b>		oPE .....	210
n1-02 .....	174	oPE01 .....	210
n2-01 .....	175	oPE02 .....	210
n2-02 .....	175	oPE03 .....	210
n2-03 .....	175	oPE04 .....	211
ND .....	58	oPE05 .....	211
ndAT .....	220	oPE06 .....	211
NetRef/ComRef Function Selection .....	90	oPE07 .....	211
Network Termination .....	316	oPE08 .....	212
Noise From the Drive or Motor Cables When the Drive is Powered On .....	228	oPE09 .....	212
No-Load Current Alarm .....	215	oPE10 .....	212
No-Load Current Error .....	215	oPE11 .....	213
Normal Duty .....	58	oPE13 .....	213
nSE .....	189	oPE15 .....	213
Number of Auto Restart Attempts .....	145, 284	oPE16 .....	213
Number of Motor Poles .....	78, 166, 294	oPE18 .....	213
Number of Run Commands .....	300	oPE Fault Parameter .....	297
Number of Run Commands Counter Initialization .....	164	Open Loop Vector Control .....	175, 227, 229
Number of Speed Search Restarts .....	32	Open Loop Vector Control Mode Tuning .....	175
		Open Loop Vector Control Mode Tuning Parameters .....	175
		Operation Errors .....	177, 180
		Operation Selection at Deviation (dEv) .....	85
		Operation Selection at Overspeed (oS) .....	84
		Operation Selection at PG Open Circuit (PGo) .....	84
		Operation Selection when Digital Operator is Disconnected .....	162, 291
		Operation Status Monitors .....	169
		Operator Programming Errors .....	210
		Operator Related Settings .....	159
		oPr .....	194
		Option card connection error (CN5-A) .....	190
		Option Card Connection Error at Option Port CN5-A .....	190
		Option Card Connection Error at Option Port CN5-C .....	191
		Option card error occurred at option port CN5-A .....	190
		Option card error occurred at option port CN5-B .....	191
		Option card error occurred at option port CN5-C .....	191
		Option Card External Fault .....	186, 203
		Option Card Fault at Option Port CN5-A .....	190
		Option Card Fault at Option Port CN5-B .....	190
		Option Card Fault at Option Port CN5-C .....	191
		Option Communication Error .....	182, 201
		Option Frequency Reference .....	301
		Option Settings .....	84
		oS .....	194, 207
		Oscillation or Hunting .....	228
		Output Current .....	296
		Output Current 1 During Speed Search .....	31
		Output Current at Previous Fault .....	298
		Output Current Imbalance .....	188
		Output Frequency .....	296
		Output Frequency after Soft Start .....	297
		Output Frequency at Previous Fault .....	298
		Output Frequency is not as High as Frequency Reference .....	229
		Output Frequency Reduction During Overheat Alarm .....	151
<b>O</b>			
o2-01 .....	224		
o2-04 .....	174		
oC .....	189		
oFA00 .....	190		
oFA01 .....	190		
oFA03 to oFA06 .....	190		
oFA10 .....	190		
oFA11 .....	190		
oFA12 to oFA17 .....	190		
oFA30 to oFA43 .....	190		
oFb00 .....	190		
oFb01 .....	190		
oFb02 .....	190		
oFb03 to oFb11 .....	191		
oFb12 to oFb17 .....	191		
oFC00 .....	191		
oFC01 .....	191		
oFC02 .....	191		
oFC03 to oFC11 .....	191		
oFC12 to oFC17 .....	191		
Offset Frequency .....	73, 304		
oH .....	191, 206		
oH1 .....	192		
oH2 .....	206		
oH3 .....	192, 206		
oH4 .....	192		
oH5 .....	192, 206		
oH6 .....	193		
oH Alarm Location Monitor .....	302		

Output Ground Fault Detection Selection .....	152, 286	PG 2 Signal Selection .....	86
Output of speed control (ASR) (for Simple V/f PG).....	303	PG-B3 Settings .....	84
Output Phase Loss .....	188	PG Disconnect (for any control modes using a PG option card) .....	196
Output Phase Loss Protection .....	286	PG Disconnect (for Control Mode with PG) .....	208
Output Phase Loss Protection Selection .....	152	PG Hardware Fault (detected when using a PG-X3 option card) ...	196, 208
Output Power .....	296	PG Number of Pulses Per Revolution .....	166
Output Power at Previous Fault .....	299	PGo .....	196, 208
Output Terminal Status .....	297	PGoH .....	196, 208
Output Terminal Status at Previous Fault .....	299	PG Open-Circuit Detection Time .....	84
Output Voltage at Previous Fault .....	298	PG Option Card Disconnection Detection 1 .....	86
Output Voltage Detection Fault .....	200, 209	PG Option Card Disconnection Detection 2 .....	86
Output Voltage Limit Operation Selection .....	50	PG Option Card Port for Motor 2 Selection .....	86
Output Voltage Reference .....	296	PG Speed Control Card Settings .....	84
Output Voltage Reference (Vd) .....	303	PG-X3 Settings .....	84
Output Voltage Reference (Vq) .....	303	Phase Order Selection .....	24
ov .....	195, 207	PID Accel/Decel Time .....	39
OV Alarm Location Monitor .....	302	PID Block Diagram .....	35
Overcurrent .....	189	PID Control .....	33
Overexcitation Deceleration .....	142	PID Feedback .....	303
Overexcitation Deceleration Gain .....	158, 288	PID Feedback High Detection Level .....	39
Overexcitation Operation Selection .....	158, 289	PID Feedback High Detection Time .....	39
Overheat 1 (Heatsink Overheat) .....	192	PID Feedback Input Methods .....	34
Overheat Alarm Level .....	112, 286	PID Feedback Loss .....	187, 204
Overheat Pre-Alarm Operation Selection .....	113, 286	PID Feedback Loss Detection Selection .....	38
Overspeed (for Control Mode with PG) .....	194, 207	PID Feedback Low Detection Level .....	38
Overspeed Detection Delay Time .....	84	PID Feedback Low Detection Time .....	38
Overspeed Detection Level .....	84	PID Fine Tuning .....	42
Overtorque 1 .....	207	PID Function Setting .....	36
Overtorque 2 .....	207	PID Input (feedback) .....	303
Overtorque Detection 1 .....	194	PID Input Limit .....	40
Overtorque Detection 2 .....	194	PID Monitors .....	169
Overtorque Detection Operation .....	146	PID Offset Adjustment .....	36
Overvoltage .....	195	PID Output .....	303
Overvoltage Suppression Function .....	143	PID Output Fault .....	229
Overvoltage Suppression Function Selection .....	143	PID Output Gain Setting .....	37
ov Suppression Function Selection .....	282	PID Output Level Selection .....	37
		PID Output Limit .....	36
		PID Output Lower Limit .....	40
		PID Output Reverse Selection .....	37
		PID Primary Delay Time Constant .....	37
		PID Setpoint .....	303
		PID Setpoint Display Digits .....	41
		PID Setpoint Input Methods .....	34
		PID Setpoint Scaling .....	40
		PID Setpoint Selection .....	40
		PID Setpoint User Display .....	41
		PID Setpoint Value .....	40
		PID Sleep .....	39
		PID Sleep Delay Time .....	39
		PID Sleep Function Start Level .....	39
		PM Inductance Error .....	217
		Power Unit Output Phase Loss 3 .....	188
		Predefined V/f Patterns .....	75
		Preset Reference Timing Diagram .....	61
		Previous Fault .....	298
		PROFIBUS-DP Clear Mode Selection .....	91
		PROFIBUS-DP Data Format Selection .....	91
		PROFIBUS-DP Node Address .....	91
		PROFIBUS-DP Parameters .....	89, 91

**P**

Parameter Range Setting Error .....	210
Parameter Selection Error .....	212
Parameters for KEB Ride-Thru .....	136
Parameters to Minimize Motor Hunting and Oscillation .....	176
PASS .....	208
Password .....	11
Password Setting .....	11
P Control .....	33
Peak Hold Current .....	301
Peak Hold Output Frequency .....	301
PF .....	196
PG 1 Division Rate for PG Pulse Monitor .....	85
PG 1 Gear Teeth 1 .....	86
PG 1 Gear Teeth 2 .....	86
PG 1 Pulses Per Revolution .....	84
PG 1 Rotation Selection .....	85
PG 1 Signal Selection .....	86
PG 2 Division Rate for PG Pulse Monitor .....	85
PG 2 Gear Teeth 1 .....	86
PG 2 Gear Teeth 2 .....	86
PG 2 Pulses Per Revolution .....	84
PG 2 Rotation Selection .....	85

Proportional Gain Setting (P) .....	36	Single Drive KEB Ride-Thru 1 .....	133
PTC .....	119	Single Drive KEB Ride-Thru 2 .....	133
PUF .....	196	Slave Address .....	324
Pulse Monitor Selection Error .....	213	Slip Compensation .....	48
Pulse Train Input/Output .....	104	Slip Compensation Gain .....	48, 175
Pulse Train Input Bias .....	125	Slip Compensation Limit .....	49
Pulse Train Input Filter Time .....	125	Slip Compensation Primary Delay Time .....	49, 175
Pulse Train Input Gain .....	125	Slip Compensation Selection during Regeneration .....	49
Pulse Train Input Minimum Frequency .....	125	Soft Charge Bypass Relay Maintenance .....	300
Pulse Train Input Scaling .....	125	Soft Charge Bypass Relay Maintenance Time .....	205
Pulse Train Input Terminal RP Function Selection .....	124	Soft CLA Selection .....	286
Pulse Train Monitor Scaling .....	125	Soft Starter Speed Reference at Previous Fault .....	299
Pulse Train Monitor Selection .....	125	Software Current Limit Selection .....	153
<b>Q</b>		Software No. (PWM) .....	298
q-axis ACR Output .....	303	Software No. of Master CPU (Flash) .....	298
<b>R</b>		Software No. of Slave CPU (ROM) .....	298
Ramp to stop .....	20	Sound from Motor .....	229
Rated Current Setting Alarm .....	214	Speed/Torque Control Switchover Time .....	72
Rated Slip Error .....	216	Speed Agree 1 Time Chart .....	106
rdEr .....	220	Speed Agree 2 Time Chart .....	109
READ .....	162	Speed Agreement Detection Level .....	144, 283
rEAd .....	220	Speed Agreement Detection Level (+/-) .....	144, 283
Reading Drive MEMOBUS/Modbus Register Contents .....	326	Speed Agreement Detection Selection .....	144
Reading Parameter Settings .....	220	Speed Agreement Detection Width .....	144, 283
Regenerative Torque Limit mode selection .....	286	Speed Agreement Detection Width (+/-) .....	144, 283
Reset Communication Parameters .....	90	Speed Control Integral Time 1 .....	207
Resistance Tuning Error .....	214	Speed Control Proportional Gain 1 .....	207
Response Messages from Drive to Master .....	323	Speed Deviation (for Control Mode with PG) .....	184
Reverse Direction Output Example Time Chart .....	111	Speed Deviation (when using a PG option card) .....	202
Reverse Operation Selection .....	22	Speed Estimation Type Speed Search .....	28
Reverse Prohibited Error .....	217	Speed Feedback Detection Control (AFR) Tuning .....	156
Reverse Regenerative Torque Limit .....	149, 285	Speed Feedback Detection Control (AFR) Gain .....	156, 288
Reverse Torque Limit .....	149, 285	Speed Feedback Detection Control (AFR) Time Constant 1 .....	157, 288
rF .....	196	Speed Feedback Detection Control (AFR) Time Constant 2 .....	157, 288
rH .....	197	Speed Limit .....	71
rr .....	197	Speed Limitation .....	69
RS-422 Interface .....	317	Speed Limit Bias .....	69, 71
RS-485 Interface .....	317	Speed Limit Selection .....	71
RTS Control Selection .....	122, 320	Speed Search .....	20
rUn .....	208	Speed Search Deactivation Current .....	30
Run Command/Frequency Reference Source Selection Error .....	211	Speed Search Deceleration Time .....	31
Run Command at Power Up .....	25	Speed Search Delay Time .....	31
Run Command Method Selection .....	123, 321	Speed Search Detection Compensation Gain .....	31
Run Command Selection .....	224	Speed Search Method Selection .....	32
Run Command Selection 1 .....	19, 237	Speed Search Restart Current Level .....	32
Run Command Selection 2 .....	25	Speed Search Restart Detection Time .....	32
Run command selection while in Programming Mode .....	24	Speed Search Selection at Start .....	30
Run Command Source Selection .....	301	Speed Search Wait Time .....	32
<b>S</b>		Stall Prevention .....	139, 176
Safe Disable Signal Input .....	204	Stall Prevention Detection Time .....	143
SC .....	197	Stall Prevention Level during Acceleration .....	140, 282
S-Curve Characteristics .....	48, 176	Stall Prevention Level during Run .....	142, 282
SE .....	208	Stall Prevention Limit during Acceleration .....	139, 282
Self-diagnosing function of the serial communication interface circuits .....	346	Stall Prevention Selection during Acceleration .....	139, 282
SEr .....	197	Stall Prevention Selection during Deceleration .....	141, 282
Serial Communications Cable Connection Terminals (TB4) .....	316	Stall Prevention Selection during Run .....	142, 282
Serial Communication Transmission Error .....	202	Stator Resistance Error .....	217
		STOP button Input .....	215
		STOP Key Function Selection .....	161, 290
		Stopping Method after Communication Error .....	122, 319

Stopping Method Selection .....	20	Torque Control Setting Error .....	213
SvE .....	197	Torque Control Signal Polarity .....	69
Switching Between Torque and Speed Control .....	70	Torque Detection .....	108
System KEB Ride-Thru 1 .....	133	Torque Detection Level 1 .....	147, 284
System KEB Ride-Thru 2 .....	133	Torque Detection Level 2 .....	147, 284
<b>T</b>			
Target DC Bus Voltage for Overvoltage Suppression and Stall Prevention .....	143	Torque Detection Selection 1 .....	147, 284
Task Complete .....	219	Torque Detection Selection 2 .....	147, 284
Terminal A1 Bias Setting .....	115	Torque Detection Time 1 .....	147, 284
Terminal A1 Function Selection .....	114	Torque Detection Time 2 .....	147, 284
Terminal A1 Gain Setting .....	115	Torque Limit .....	119
Terminal A1 Signal Level Selection .....	114	Torque Limit Control Method Selection during Accel/Decel .....	149, 285
Terminal A2 Bias Setting .....	116	Torque Limit Enable Time delay at start .....	286
Terminal A2 Function Selection .....	116	Torque Limit Integral Time Constant .....	149, 285
Terminal A2 Gain Setting .....	116	Torque Limits .....	176
Terminal A2 Signal Level Selection .....	116	Torque Reference .....	296
Terminal A3 Bias Setting .....	116	Torque Reference / Torque Limit Selection from Comm. Option .....	90
Terminal A3 Function Selection .....	116	Torque Reference at Previous Fault .....	299
Terminal A3 Gain Setting .....	116	Torque Reference Delay Time .....	71
Terminal A3 Signal Level Selection .....	115	Torque Saturation Error .....	217
Terminal Board Connection Error .....	183	Troubleshooting without Fault Display .....	223
Terminal Connections for Communication Self-Diagnostics .....	346	TrPC .....	208
Terminal M1-M2 Function Selection .....	104	Tuning Errors .....	177
Terminal M1-M2 Output Selection .....	88	Types of Alarms, Faults, and Errors .....	177
Terminal M3-M4 Output Selection .....	89	<b>U</b>	
Terminal P1-PC Output Selection .....	88	U1-01 .....	224, 226
Terminal P2-PC Output Selection .....	88	U1-07 .....	224
Terminal P3-PC Output Selection .....	88	U1-09 .....	224
Terminal P4-PC Output Selection .....	88	U2, U3 Initialization .....	164
Terminal P5-PC Output Selection .....	88	U2, U3 Initial Value Selection .....	291
Terminal P6-PC Output Selection .....	88	U2-02 .....	221
Terminal V1 Monitor Bias .....	88	U2-03 through U2-17 .....	221
Terminal V1 Monitor Gain .....	88	U4-05 .....	209
Terminal V1 Monitor Selection .....	88	UL3 .....	198, 209
Terminal V1 Signal Level .....	88	UL4 .....	198, 209
Terminal V2 Monitor Bias .....	88	UL5 .....	198
Terminal V2 Monitor Gain .....	88	UnbC .....	198
Terminal V2 Monitor Selection .....	88	UnbC Current Max Location Monitor .....	302
Terminal V2 Signal Level .....	88	Undertorque Detection 1 .....	198, 209
Thermistor Disconnect .....	197, 208	Undertorque Detection 2 .....	198, 209
THo .....	197, 208	Undertorque Detection Operation .....	146
Timer Function Off-Delay Time .....	32	Undervoltage .....	209
Timer Function On-Delay Time .....	32	Undervoltage 3 .....	199
Too Many Speed Search Restarts .....	197	Undervoltage 3 (Soft-Charge Bypass Circuit Fault) .....	199
Torque Compensation .....	51	Undervoltage Detection Level (Uv1) .....	138, 281
Torque Compensation at Forward Start .....	52	Unexpected Noise from Connected Machinery .....	228
Torque Compensation at Reverse Start .....	52	Unidirectional Speed Limit Bias .....	72
Torque Compensation Gain .....	51, 174	Unit Code .....	161
Torque Compensation Primary Delay Time .....	52, 174	Unit Selection for MEMOBUS/Modbus Register 0025H .....	123, 320
Torque Compensation Primary Delay Time 2 .....	52	Up/Down 2 Function .....	63
Torque Compensation Primary Delay Time Constant 1 .....	175	Up/Down 2 Operations .....	103
Torque Compensation Primary Delay Time Constant 2 .....	175	Up/Down Command Operation .....	98
Torque Compensation Time Constant .....	52	Up/Down Frequency Reference Limit Selection .....	67
Torque Control .....	67	User Monitor Selection after Power Up .....	159, 290
Torque Control Block Diagram .....	68	User Parameter Automatic Selection .....	17, 236
Torque Control Input Value Selection .....	68	User Parameter Default Value .....	161, 290
Torque Control Reference Sources .....	68	User Parameters 1 to 32 .....	17, 236
Torque Control Selection .....	71	User-Set Display Units Decimal Display .....	160
		User-Set Display Units Maximum Value .....	160
		User Set Speed Agree 1 Time Chart .....	106

User Set Speed Agree 2 Example with a Positive L3-04 Value ..... 110  
 Uv ..... 209  
 Uv1 ..... 198  
 Uv2 ..... 199  
 Uv3 ..... 199  
 Uv4 ..... 199  
 Uv5 ..... 199  
 UV Alarm Location Monitor ..... 302

**V**

V/f Control Mode Tuning ..... 174  
 V/f Control Mode Tuning Parameters ..... 174  
 V/f Control with Simple Speed Feedback ..... 124  
 V/f Data Setting Error ..... 212  
 V/f Gain During Speed Search ..... 31  
 V/f Pattern Defaults ..... 308  
 V/f Pattern Display Unit ..... 160  
 V/f Pattern for Motor 1 ..... 74  
 V/f Pattern for Motor 2 ..... 80  
 V/f Pattern Selection ..... 74, 226  
 vAEr ..... 220  
 VERIFY ..... 162  
 vFyE ..... 220  
 voF ..... 200, 209  
 voF Alarm Location Monitor ..... 302  
 Voltage Class, Capacity Mismatch ..... 220  
 vrFy ..... 220

**W**

Water Supply Pump Application ..... 14  
 Watt Hour Output Example ..... 114  
 Watt Hour Output Unit Selection ..... 113  
 Wiring Diagram for 2-Wire Sequence ..... 101  
 WRITE ..... 162  
 Writing Parameter Settings ..... 219  
 Writing to Multiple Registers ..... 326

**Z**

Zero Servo ..... 44  
 Zero Servo Completion Width ..... 45  
 Zero Servo Fault ..... 197  
 Zero Servo Gain ..... 45  
 Zero-Speed Time Chart ..... 106  
 Z Pulse Correction Error ..... 218  
 Z Pulse Fault ..... 185  
 Z Pulse Noise Fault Detection ..... 185

---

## Revision History

The revision dates and the numbers of the revised manuals appear on the bottom of the back cover.

Date of Publication	Revision Number	Section	Revised Content
June 2011	-	-	First Edition. This manual supports A1000 HHP drive software version VSL901012.

---

**This Page Intentionally Blank**

# YASKAWA AC Drive – A1000 HHP

## High Performance Vector Control Drive

### Technical Manual

---

#### **YASKAWA AMERICA, INC.**

2121 Norman Drive South, Waukegan, IL 60085, U.S.A.  
Phone: (800) YASKAWA (927-5292) or 1-847-887-7000 Fax: 1-847-887-7310  
<http://www.yaskawa.com>

#### **DRIVE CENTER (INVERTER PLANT)**

2-13-1, Nishimiyaichi, Yukuhashi, Fukuoka 824-8511, Japan  
Phone: 81-930-25-3844 Fax: 81-930-25-4369  
<http://www.yaskawa.co.jp>

#### **YASKAWA ELECTRIC CORPORATION**

New Pier Takeshiba South Tower, 1-16-1, Kaigan, Minatoku, Tokyo 105-6891, Japan  
Phone: 81-3-5402-4502 Fax: 81-3-5402-4580  
<http://www.yaskawa.co.jp>

#### **YASKAWA ELÉTRICO DO BRASIL LTDA.**

Avenda Fagundes Filho, 620 Bairro Saude, São Paulo, SP04304-000, Brasil  
Phone: 55-11-3585-1100 Fax: 55-11-5581-8795  
<http://www.yaskawa.com.br>

#### **YASKAWA EUROPE GmbH**

Hauptstraße 185, 65760 Eschborn, Germany  
Phone: 49-6196-569-300 Fax: 49-6196-569-398  
<http://www.yaskawa.eu.com>

#### **YASKAWA ELECTRIC UK LTD.**

1 Hunt Hill Orchardton Woods, Cumbernauld, G68 9LF, United Kingdom  
Phone: 44-1236-735000 Fax: 44-1236-458182  
<http://www.yaskawa.co.uk>

#### **YASKAWA ELECTRIC KOREA CORPORATION**

7F, Doore Bldg. 24, Yeoido-dong, Yeoungdungpo-gu, Seoul, 150-877, Korea  
Phone: 82-2-784-7844 Fax: 82-2-784-8495  
<http://www.yaskawa.co.kr>

#### **YASKAWA ELECTRIC (SINGAPORE) PTE. LTD.**

151 Lorong Chuan, #04-01, New Tech Park, 556741, Singapore  
Phone: 65-6282-3003 Fax: 65-6289-3003  
<http://www.yaskawa.com.sg>

#### **YASKAWA ELECTRIC (SHANGHAI) CO., LTD.**

No. 18 Xizang Zhong Road, 17F, Harbour Ring Plaza, Shanghai, 200001, China  
Phone: 86-21-5385-2200 Fax: 86-21-5385-3299  
<http://www.yaskawa.com.cn>

#### **YASKAWA ELECTRIC (SHANGHAI) CO., LTD. BEIJING OFFICE**

Room 1011, Tower W3 Oriental Plaza, No. 1 East Chang An Ave., Dong Cheng District, Beijing, 100738, China  
Phone: 86-10-8518-4086 Fax: 86-10-8518-4082

#### **YASKAWA ELECTRIC TAIWAN CORPORATION**

9F, 16, Nanking E. Rd., Sec. 3, Taipei, 104, Taiwan  
Phone: 886-2-2502-5003 Fax: 886-2-2505-1280



YASKAWA AMERICA, INC.

In the event that the end user of this product is to be the military and said product is to be employed in any weapons systems or the manufacture thereof, the export will fall under the relevant regulations as stipulated in the Foreign Exchange and Foreign Trade Regulations. Therefore, be sure to follow all procedures and submit all relevant documentation according to any and all rules, regulations and laws that may apply. Specifications are subject to change without notice for ongoing product modifications and improvements.

© 2011 YASKAWA AMERICA, INC. All rights reserved.

Manual No. SIEP YEAHHP 01